



Quality Family Planning
www.fpntc.org

Providing Quality Contraceptive Counseling and Education

A Toolkit for Training Staff

May 2016





Quality Family Planning
www.fpntc.org

This toolkit was developed by Cardea, www.cardeaservices.org

Funding was provided by the Department of Health and Human Services, Office of Population Affairs.
The information presented does not necessarily represent the views of OPA, HHS or FPNTC.



Introduction

Providing quality counseling is an essential component of client-centered, culturally proficient care. This toolkit is based on Providing *Quality Family Planning Services (QFP): Recommendations of CDC and OPA*¹ and contains an overview of the QFP Principles for Providing Quality Counseling.

What?

Included in the toolkit are instructional tools and training activities along with job aids to help staff practice and apply the *QFP Principles for Providing Quality Counseling*. These training materials are designed to help clinic staff **understand** the key Quality Counseling Principles within an easy to remember contraceptive counseling process and **practice** skills and strategies that support an interactive, client-centered approach to contraceptive counseling and education.

Why?

When staff understand and can apply the five principles for quality counseling as defined in the *Providing Quality Family Planning Services: Recommendations of CDC and OPA* they are better prepared to conduct high quality counseling sessions. Based on the evidence included in the QFP we know that when clients receive quality counseling they are more satisfied, better informed, and more prepared to use their contraceptive method correctly and consistently. This toolkit helps prepare staff to apply the Quality Counseling Principles specifically to contraceptive counseling and education.

Who?

This toolkit is designed for staff who train others in a family planning or reproductive healthcare setting and are familiar with reproductive health content and clinic services. These trainers may include clinic managers, staff trainers, or other staff such as clinical providers, who train, orient and/or provide coaching or mentoring for other clinic staff. You might use the toolkit materials with individuals or in group settings such as staff meetings, clinic trainings, staff retreats and/or with new staff orientation.

You can adapt these materials to meet the training needs of various clinic staff with different roles and responsibilities.

How?

This toolkit is presented in five modules that provide background and recommended preparation for the trainer, key concepts to ensure a consistent approach to these topics, and training activities (including step-by-step instructions) with printed materials. References and additional resources are listed in Appendix A.

¹ Providing Quality Family Planning Services: Recommendations of CDC and U.S. Office of Population Affairs (OPA), April, 2014
<http://fpntc.org/sites/default/files/resource-library-files/QFP%20Recommendations%20MMWR%20April%202014.pdf>



Acknowledgments

Thank you to the individuals and organizations who contributed their time and expertise to this toolkit:

Authors

Karen Dluhosh, MC
Erin Edelbrock, MPA
Kimberly Aumack Yee
Sandy Rice, MEd
Cardea

Graphic Design

Eric Wheeler
Cardea

Expert Reviewer

Christine Dehlendorf, MD, MAS
University of California, San Francisco, School of Medicine
San Francisco, California

Contributing Organizations

Planned Parenthood Federation of America

Health Care Education & Training
Madison, Wisconsin

Field Test Sites

Access Esperanza Clinics
McAllen, Texas

Action for Boston Community Development
Boston, Massachusetts

Denver Health
Denver, Colorado

La Clínica de la Raza
Oakland, California

Planned Parenthood of the Great Northwest and the Hawaiian Islands
Seattle, Washington



Table of Contents

Module 1 **Quality Counseling Principles**

Module Preview & Preparation

- Activity 1.1* *What is Client-Centered Counseling?*
- Activity 1.2* *My Professional Role vs. My Personal Values*
- Activity 1.3* *Principles for Providing Quality Counseling*

Module 2 **Client-Centered Communication Skills**

Module Preview & Preparation

- Activity 2.1* *How to Establish Rapport*
- Activity 2.2* *The OARS Model — Essential Communication Skills*
- Activity 2.3* *Communicating with Brilliance — Practicing Your Skills*

Module 3 **Quality Education Strategies**

Module Preview & Preparation

- Activity 3.1* *Birth Control Information — Simple and Accurate*
- Activity 3.2* *Explaining Characteristics and Effective Use of a Method*
- Activity 3.3* *Birth Control — Myth Busting!*
- Activity 3.4* *What are the Seven Strategies for Effective Education?*
- Activity 3.5* *Applying the Seven Strategies to Contraceptive Education*

Module 4 **Interactive Client-Centered Decision Making**

Module Preview & Preparation

- Activity 4.1* *A “Perfect” Birth Control Method?*
- Activity 4.2* *Factors that Influence Contraceptive Decision Making*
- Activity 4.3* *Personalized and Interactive Client Assessment*
- Activity 4.4* *Client-Centered Decision Making*

Module 5 **Confirming Understanding and Making a Plan**

Module Preview & Preparation

- Activity 5.1* *Using the Teach-Back Method and Closing a Session*
- Activity 5.2* *Contraceptive Counseling and Education in Review*

-
- APPENDICES**
- Appendix A:** References & Resources
 - Appendix B:** List of Printed Materials
 - Appendix C:** Quality Counseling Handouts
 - Appendix D:** Effective Teaching Methods for Training Staff

Module 1: Quality Counseling Principles

Module Preview and Preparation

Key Concepts for Participants

1. Client-centered counseling respects each client’s unique life experiences, reflects sound ethical health care practice, and helps ensure positive health outcomes for each client.
2. Staff who provide contraceptive counseling have a professional commitment to work to prevent bias through self-awareness and by focusing on a client’s needs and goals.
3. The five key elements of Quality Counseling Principles, based on the QFP, provide a standardized client-centered counseling framework.

About This Module

This module offers a standardized counseling framework that emphasizes a professional commitment to providing client-centered contraceptive counseling services that are unbiased, culturally aware, and reflect genuine interest in learning about and addressing the client’s unique experience and needs.

The **Contraceptive Counseling Process Guide** integrates **five Quality Counseling Principles**, based on the QFP, into an easy to remember encounter process of three stages — Beginning, Middle and Closing.

Beginning (and throughout)

Principle: Establish and maintain rapport with the client

Middle

Principle: Assess the client’s needs and personalize discussions accordingly

Principle: Work with the client interactively to establish a birth control method plan

Principle: Provide information that can be understood and retained by the client

Closing

Principle: Confirm client understanding

Why This Module Matters

Building a respectful and trusting client-professional relationship through quality, client-centered counseling reflects sound ethical health care practice and will help ensure positive health outcomes for each client.

Important Terms

As you prepare to deliver this module, familiarize yourself with the following terms:

Counseling is a process that enables clients to make and follow through on decisions. Providing quality counseling is an essential component of client-centered care.

Client-centered contraceptive services are defined as contraceptive care that treats each person as a unique individual with respect, empathy and understanding. Client-centered services involve:

- Providing accurate, easy-to-understand information about contraception based on the client’s needs and goals.
- Asking questions, listening thoughtfully to the client’s answers and responding appropriately.
- Assisting clients in selecting a contraceptive method that is the best match for their personal preferences.



Culturally aware services start with understanding that each individual holds a broad range of cultural influences that include race, ethnicity, age, gender and gender identity, sexual orientation, nationality, language, economic class, education, level of ability(ies) and many other life and community experiences. Services should be respectful of the beliefs, practices and needs of each individual client.

Trainer Tip: Reflection and self-awareness are critical skills for staff working to overcome bias and provide **client-centered** and **culturally aware** services. Activity 1.2 offers opportunities to discuss and build self-awareness skills.

Trainer Tip: Work with your organization’s leaders to align this module’s Key Concepts and definitions of **client-centered** and **culturally aware** services with your agency policies and procedures to build clarity and consistency into your contraceptive services.

Additional Resources

The **Contraceptive Counseling Process Guide** is a tool that outlines the counseling process from beginning to end, highlighting key counseling behaviors and attitudes. Each module of the toolkit addresses one or more sections of this counseling guide and reinforces quality counseling principles throughout.

Module 1 provides an overview to the guide and the principles.

Module 2 focuses on communication skills and building rapport from the *beginning* of the session (and throughout).

Modules 3 and 4 detail the *middle* section of this guide with interactive education, assessment, and client-centered decision making.

Module 5 focuses on the *closing* of a session.

This guide links the quality counseling principles with corresponding actions and behaviors throughout a contraceptive counseling session. **Although the principles are listed in a particular order, counseling is an integrated and iterative process.** For example, the principles related to education and assessment are interdependent, with the counselor tailoring the education they provide as they assess the client’s existing knowledge and decision making priorities.

Contraceptive Counseling Process Guide

Process

Beginning (and throughout)

Establish and maintain rapport with the client

- ▶ Warmly greet the client by name and introduce yourself
- ▶ Be genuine, showing respect and empathy
- ▶ Ask about the client’s reason(s) for today’s visit, plan and prioritize visit
- ▶ Explain private and confidential services
- ▶ Ask open-ended questions
- ▶ Respectfully affirm what you see and hear (showing interest, support and cultural awareness)
- ▶ Show that you care by listening (verbally and non-verbally)
- ▶ Reflect on what you observe and hear, to gain a deeper understanding
- ▶ Summarize key points throughout with a focus on the client’s goals
- ▶ If using EMR, position the monitor to keep eye contact

Middle

<p>Assess the client’s needs and personalize discussions accordingly</p> <ul style="list-style-type: none"> ▶ Review and update the medical, sexual and social history ▶ Explore client preferences regarding method characteristics: frequency of use, effectiveness, how to use, menstrual changes, side effects, and benefits ▶ Ask about client knowledge and experience with birth control methods ▶ Address pregnancy and parenting intention/ambivalence along with STD/HIV protection ▶ Respectfully explore client beliefs and feelings, including ethnic, cultural, and/or individual factors that may be relevant to their birth control method decisions and method use 	<p>Work with the client interactively to establish a birth control method plan</p> <ul style="list-style-type: none"> ▶ Ask open-ended questions about concerns or possible barriers relevant to method choice ▶ Explore the client’s method preferences, and if appropriate, offer additional information about the most effective methods ▶ Help the client to optimize method choice by assisting the client in aligning their preferences with their method selection ▶ Reflect back important thoughts or feelings you hear from the client and/or feelings you sense from the discussion ▶ Clarify partner involvement and the role of others who may be important to the client’s decision making and method use ▶ Affirm and support the decision making process with a respectful, nonjudgmental approach in helping the client make a plan 	<p>Provide information that can be understood and retained by the client</p> <ul style="list-style-type: none"> ▶ Provide balanced, unbiased, tailored information about method characteristics in an interactive conversation ▶ Provide accurate information (correct use, effectiveness, benefits, side effects, potential risks, STD/HIV protection) ▶ Use clear, understandable words, images, materials, models and/or sample methods ▶ Use numbers and comparisons that are easy to understand ▶ Assess and address myths and misinformation in a respectful and affirming way ▶ Include information about STD protection and emergency contraception
---	---	--

Closing

Confirm client understanding

- ▶ Ask the client to tell and show what was learned (teach-back) and provide additional information, as needed
- ▶ Address any possible barriers to a successful plan and method use
- ▶ Confirm the client’s plan for correct method use and follow-up, including what to do if dissatisfied with the method, back-up method, and emergency contraception, as needed
- ▶ Provide contact information and future opportunities for follow up, other methods or services
- ▶ Summarize with key points and provide a friendly close

Quality Family Planning
www.fpntc.org

FPNTC is supported by the Office of Population Affairs of the U.S. Department of Health and Human Services. The information presented does not necessarily represent the views of OPA, DHHS, or FPNTC member organizations.

April 2016



Training Activities in this Module

Activity 1.1 What is Client-Centered Counseling? (30–45 minutes)

Purpose: Participants will be able to describe the meaning and rationale of client-centered contraceptive counseling.

In this activity you will:

- Ask participants to reflect on a personal experience reflective of a client-centered approach, in which they were in the role of the ‘client.’
- Ask participants to describe the impact of a client-centered approach on their experience.
- Lead participants in a discussion of the qualities, actions and behaviors that are essential in delivering client-centered counseling.

Activity 1.2 My Professional Role vs. My Personal Values (20–30 minutes)

Purpose: Participants will be able to describe the importance of a professional commitment to engage in personal self-assessment to prevent bias and focus on a client’s needs and goals.

In this activity you will:

- Guide participants in identifying and examining their own values and beliefs related to contraceptive methods and the clients they serve.
- Help participants explore strategies that can help them keep personal values separate from their professional role as they work with clients — in a client-centered manner — on topics related to contraceptive services.

Activity 1.3 Principles for Providing Quality Counseling (30–45 minutes)

Purpose: Participants will be able to describe a counseling process framework that includes a client-centered approach as a fundamental element in delivering quality family planning services.

In this activity you will:

- Provide participants with an overview of the QFP’s five Quality Counseling Principles as a client-centered approach to contraceptive services.
- Ask participants to offer examples of ways they could apply each of the five Principles and integrate client-centeredness during counseling sessions and in the overall clinic environment.
- Guide participants through the **Contraceptive Counseling Process Guide**, a counseling process framework that follows the five Quality Counseling Principles.



General Guidance for All Activities

- Suggested language for the trainer to say out loud is in italics and shaded. We encourage you to cover these points in your own words and add additional comments relevant to your site.

Example:

This activity is to help us step back and think about what "client-centered" really means and how it's demonstrated when a person is making a very personal and important life decision.

- We encourage you to be creative with how you present the content within the activities. Have fun, and make it your own! While the content is evidence-based and should be delivered with fidelity, there are many training approaches you could use to help your participants engage with this content. See *Effective Teaching Methods* for ideas, or incorporate your own favorite training strategies!



Activity 1.1 What is Client-Centered Counseling?

Purpose

The purpose of this activity is to clarify the meaning and rationale of client-centered contraceptive counseling. Staff will reflect on personal experiences related to a client-centered approach and identify what qualities, actions and behaviors are essential in delivering quality counseling.

Who should participate?

Appropriate for all clinic staff who provide family planning services to clients

Especially important for staff who provide contraceptive counseling and education

Time

30–45 minutes

Preparation

Review the following:

- Module 1 Preview & Preparation
- Activity 1.1 Trainer Reference Notes

Materials

Supplies:

- 3 x 5 notecards (at least 1 per participant)
- Blank large paper to stick/tape to the wall (enough sheets for groups of 2-3 participants to each have one)
- Pens, markers
- Additional large paper or whiteboard (optional)

Resources

Have at least one printed copy available for reference:

- Providing Quality Family Planning Services (QFP): Recommendations of CDC and OPA, Appendix C
- Any agency policies or procedures that will support the client-centered, culturally aware services provided in your clinic setting

Detailed Instructions

1. Introduce the activity:

This activity is to help us step back and think about what “client-centered” really means and how it’s demonstrated when a person is making a very personal and important life decision.

*The question we’ll answer is — What is it a person does, says, or “projects” non-verbally that helps us **feel safe, relaxed and open**, encouraging us to **ask questions, share concerns, and learn new ideas** or facts?*

You may want to write the **bolded key words** above on a white board or large paper to refer to throughout the activity.

This activity will help us recognize personal experiences that reflected a client-centered approach. It will also help us commit to self-assessment, to build on what we already do that reflects client-centered qualities and skills.

2. Review the Key Concept for Participants.

Optional: Post on large paper or white board.

*The following Key Concept is the important takeaway for this activity. We’ll talk about **what** client-centered counseling looks like, but it’s also important to remember **why** we do it:*

- **Client-centered counseling respects each client’s unique life experiences, reflects sound ethical health care practice, and helps ensure positive health outcomes for each client.**

3. Give each participant a 3 x 5 notecard and give the following instructions:

First, take a few moments of personal reflection and think about a time in your life when you were considering a decision about birth control, being sexually active, or even thinking about if you were ready to be a parent. Was there a person you talked to about this decision?

- *They could have been a health care provider, educator, counselor... or, this person could have been a friend or a relative.*
- *Or — think of the kind of person you would have liked to talk with...*

Write on one side of your 3 x 5 card a few words that would describe the key qualities and skills this person brought to your conversation.

- *How would you describe how the person made you feel?*
- *What did this person do?*
- *What did this person say that was helpful for you?*
- *What else could they have done to make you feel safe and relaxed?*

If participants are struggling to list qualities and skills, see the **Trainer Reference Notes** at the end of this activity for ideas you could share.

At-a-Glance

Introduction

What helps people...

- Feel safe, relaxed and open?
- Ask questions?
- Share concerns?
- Learn new ideas?

How can we self-assess and improve?

Key Concept

Client-centered counseling respects each client’s unique life experiences, reflects sound ethical health care practice, and helps ensure positive health outcomes for each client

Reflection



Participants think of a time they talked with someone about a reproductive health decision.

Then write:

- How did this person make you feel?
- What did they do? Say?
- What else could they have done?

4. Ask participants to form groups of 2 or 3. Give each group either a large blank sheet of paper, and give the following instructions:

- Take a few minutes to have each person in your group talk about the person that you thought about. **What key qualities, words or behaviors were helpful?** You do not need to share what decision you were considering, or the identity of the person you thought about.
- Next, thinking about the qualities or behaviors you've talked about, use the blank paper to **draw an "ideal counselor"** you would want to talk to about an important reproductive health decision.
- **Be creative!** You can give your counselor any qualities or other descriptors of what you would want this person to be.

5. Ask each group to present their "ideal counselor" to the full group.

6. Lead a full group debrief, asking participants to reflect on the important qualities and behaviors they identified. You may ask questions like:

- What seems to be the most important quality that was identified?
- What did you talk about as you identified qualities and behaviors?
- Is there anything missing from our "ideal counselors?"
- How common are these "ideal counselors?"
- What training would be helpful in developing these qualities?
- What other observations do you have?

7. Present a definition of client-centered contraceptive counseling:

You may want to write this definition on large paper or a whiteboard.

Client-centered is defined as providing care that treats each person as a unique individual with respect, empathy and understanding. It involves:

- Providing accurate, easy to understand information based on the client's needs and goals; and
- Asking questions, listening thoughtfully to the client's answers and responding appropriately;
- Assisting clients in selecting a contraceptive method that is the best match for their personal preferences.

Any comments or observations about this definition?

Small Groups:
Draw "Ideal Counselor"

- Groups of 2-3
- Distribute large paper, markers



Groups Present

Full Group Debrief

- What qualities?
- Anything missing?
- Other observations?

Definition

Client-centered = treating each person as a unique individual with respect, empathy, and understanding

- Accurate, clear, tailored info
- Questions & listening
- Matching methods to client preferences

8. **Ask participants to do a final reflection.**

- Take 2 minutes to reflect on what you have just experienced.
- On the **second side of your 3 x 5 notecard**, write 2-3 qualities and/or behaviors you already feel you can demonstrate, and also 2-3 qualities or behaviors you feel you could improve.
- Lastly, think about and write down what training or coaching could help you come closer to that "ideal client-centered counselor."

9. **Wrap up the activity**, sharing concluding/summarizing comments such as:

Providing high quality, client-centered, culturally aware contraceptive services is our goal. We aim to:

- Identify what we do well and ensure its consistency;
- Discover where and what we can improve; and
- Build training, coaching, and system improvements into our work.

This in turn helps us with our ultimate goal, to provide the best care possible to clients that will allow them to achieve their personal goals.

Reflection

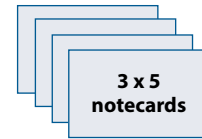

- I already...
- I could improve...
- I need training on...

**Wrap-Up
Activity 1.1 Complete**





Trainer Reference Notes — Step 3

Here are examples of client-centered qualities and skills for you to help prompt participants.

Rather than describing these in detail to the participants, help them explore and identify examples that specifically fit their experience.

- Good listener
- Respects my privacy by not telling others
- Doesn't tell me what to do
- Asks me good questions about what I want
- Somewhat knowledgeable but not "know it all"
- Respects my feelings



Activity 1.2 My Professional Role vs. My Personal Role

Purpose

The purpose of this activity is to help staff explore strategies that can help them keep personal values separate from their professional role as they work with clients on topics related to contraceptive services.

Who should participate?

Appropriate for all clinic staff who provide family planning services to clients

Especially important for staff who provide contraceptive counseling and education

Time

20–30 minutes

Preparation

Review the following:

- Module 1 Preview & Preparation
- Activity 1.2 Handouts

Materials

Handouts:

Make one copy for each participant:

- Exploring Our Personal Values Worksheet
- Being Client-Centered — A Self-Assessment

Supplies:

- Large paper, with “Our personal values...” list written, to stick/tape to the wall
- Large paper or whiteboard you can use to capture Group Agreements
- Optional: Large paper, with activity goal written, to stick/tape to the wall
- Markers

Resources

Have at least one printed copy available for reference:

- Providing Quality Family Planning Services (QFP): Recommendations of CDC and OPA, Appendix C

Group Agreements

Goal:

A commitment to prevent bias by being aware of our own individual beliefs and always focusing on a client’s needs & goals

Our personal values...

1. Are important to each of us
2. May change over time
3. May not be shared by clients
4. Could contribute to bias or undue influence on clients
5. Should be identified through reflection and self-awareness
6. Should be separated from our professional role

Detailed Instructions

1. Introduce the activity:

This activity will help us explore and identify our personal beliefs and values about providing contraceptive services. We will talk about our professional role in delivering client-centered services and the strategies we use to separate our beliefs from our clinic role when working with clients. Our goal is to be aware of our own beliefs and ensure that we always focus on a client's needs and goals and prevent bias.

2. Review the Key Concepts for Participants.

Optional: Post on large paper or white board.

Here is the number one thing I hope you'll remember from this activity:

- **Staff who provide contraceptive counseling have a professional commitment to work to prevent bias through self-awareness and by focusing on a client's needs and goals.**

And here's the key concept that we introduced in the previous activity:

- *Client-centered counseling respects each client's unique life experiences, reflects sound ethical health care practice, and helps ensure positive health outcomes for each client.*

3. Create and post Group Agreements for this activity:

Brainstorm your Group Agreements by asking participants what would help them to feel safe and get the most out of this activity. You can also use the examples posted below. Take notes and post the Group Agreements where participants can see them throughout the activity.

Trainer Note: Some participants may be quiet during this activity. You can offer participants the option to pass, but encourage participants to take risks and share their thoughts. If they choose to pass, encourage them to listen to others and privately engage in a self-reflective process.

SAMPLE — Group Agreements

The goal is to ensure a safe environment for candid group participation.

- ✓ You have the right to pass — but challenge yourself to take risks
- ✓ Confidentiality (no stories, names or personal facts leave the room)
- ✓ Be respectful of diverse opinions
- ✓ Don't talk over each other
- ✓ Keep an open mind
- ✓ Ask questions
- ✓ Be inclusive of each other
- ✓ Start on time and end on time
- ✓ Take care of your needs
- ✓ Have fun (as a team/group)!

At-a-Glance

Introduction

GOAL:

A commitment to prevent bias by being aware of our own individual beliefs and always focusing on a client's needs & goals

Key Concept

Staff have a professional commitment to work to prevent bias through self-awareness and by focusing on the client's needs and goals

Group Agreements

Group Agreements

4. Give instructions **before** handing out “Exploring Our Personal Values”

This activity uses sentence stems to let you quickly answer with the first idea that comes to mind. For instance — if I said: The best dessert in the world is... What's the first thing that comes into your mind?

- Now I'll hand out the worksheet — **keep it face down until I say start!**
- When I say start, quickly read each of the 13 sentence stems and write the first thing that comes to mind. **Be brief** — only a few words. And try to **be honest** — this is anonymous (**don't include your name!**).
- When you've finished, **fold your paper in half** so I know you are done.

5. Hand out the Exploring Our Personal Values worksheet **face down**.

When all worksheets are distributed, give the **start** signal and instruct participants to turn the sheet face up and begin.

Tell participants to work quickly. When most are over halfway done with the worksheet, give a 1-minute warning.

6. Prepare to debrief the worksheet.

Gather the worksheets, make sure they have no personal identification marks, mix them up and give to one trusted person.

Trainer Tip: You will likely not have time to read all the responses — **choose 3 or 4 of the numbered sentence stems on the worksheet to focus on** (choose on your own, or with the help of the group). Ask the trusted person to read each response for the chosen sentence stems.

Worksheet Directions

- Keep it face down until I say “start”!
- Write the first thing that comes to mind
- Be brief
- **Don't** write your name

Values Worksheet

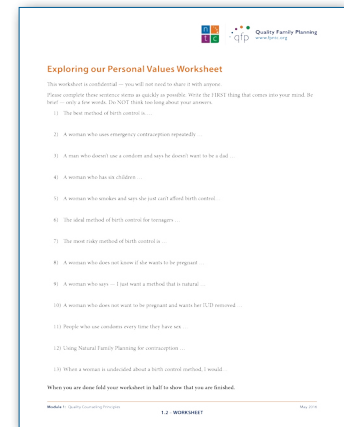

Prepare to Debrief

- Gather worksheets
- Check for names or identifying marks
- Mix them up and give to one trusted person to read aloud



7. **Lead Part 1 of a debrief**, discussing reactions to the worksheet.

Remind participants:

The goal for the activity is to encourage us to identify our own values and potential biases (we all have them) and explore strategies to keep them separate from our clinic role.

Talk about **reactions and challenges:**

- *What are your general reactions to these topics?*
- *What sentence stems were hard for you? Did any surprise you?*
- *What did you learn about your personal values and potential biases?*

Trainer Tip: Emphasize items where there were a range of responses, to show how personal values and beliefs differ from person to person.

8. **Read through the “Our personal values...” list and lead a brief discussion.**

- *Why are numbers 5 (identifying values) and 6 (separating values from our professional role) so important?*
- *Any other comments or reactions?*

Remember: Our role is to help clients explore their own values, beliefs, and options

9. **Lead Part 2 of the debrief**, discussing ways to separate values from work.

- *What effective strategies have you used in the past to separate personal values from your professional role?*
- *What can we do as a team to help each other?*
- *What has been helpful to hear today — anything you might try?*
- *What other comments or suggestions do you have?*

Debrief: Part 1

- General reactions?
- Challenges? Surprises?
- What did you learn about your values and potential biases?

Our Personal Values

Our personal values...

1. Are important to each of us
2. May change over time
3. May not be shared by clients
4. Could contribute to bias or undue influence on clients
5. Should be identified through reflection and self-awareness
6. Should be separated from our professional role

Debrief: Part 2

What strategies can you use to separate personal values from your professional role?

10. Discuss the importance of self-assessment/self-awareness in providing contraceptive counseling.

The activity we just did helped us increase self-awareness. **Self-awareness is the most powerful way to overcome bias** and limit its influence in our interactions with clients. **Why do you think that is?**

Pause to hear a few responses from participants.

- Those of us who provide contraceptive counseling, like everyone else, hold stereotypes based on a client's race, gender, sexual orientation, and other cultural identities.
- **These stereotypes and biases are often unconscious, and they can affect our communication with clients** — the questions we ask, the options we offer, the decisions we make.
- Self-awareness is a process of intentionally working to become more aware of our conscious and unconscious stereotypes and how they influence our interactions with clients. Self-awareness helps us to provide quality and equitable care to **all** clients.

11. Hand out the Being Client-Centered — A Self-Assessment handout.

Tell participants the self-assessment will help them reflect on the qualities and skills discussed in this activity and Activity 1.1.

Tell participants to take 3–4 minutes to read through the list and consider their personal strengths and areas they want to improve.

After 3–4 minutes ask participants to share any thoughts or comments about the self-assessment. You may ask questions such as:

- How do I recognize my own beliefs and values about sexuality, birth control, and other related sexual or family planning practices?
- How do I maintain my commitment to client-centered care, even if a client's decision seems in conflict with my assessment of what might be more effective or is "best" for that client?
- How do I reflect on my beliefs and values to be client-centered and culturally aware of diversity in our clients and communities?

Self-Awareness Discussion

Why is self-awareness a powerful tool for limiting the impact of our biases?

- We all hold stereotypes
- Stereotypes are often unconscious
- Self-awareness helps us become more attuned to the stereotypes we hold

Self-Assessment Handout

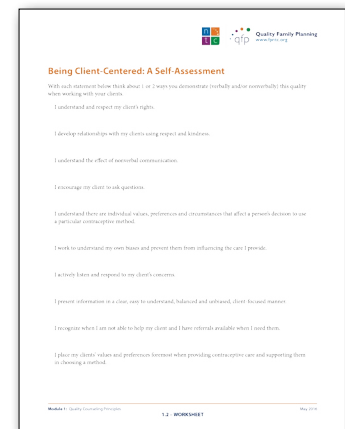

- Individually complete assessment
- Debrief as large group

12. **Wrap up the activity**, sharing summarizing comments such as:

When we talk to clients about contraception we are addressing issues that are private, and reflect various personal and cultural beliefs, values and practices that are important to each individual.

*As professionals **it's our responsibility to engage in ongoing self-reflection related to how our own values** about contraception, sexual practices, relationships and other related issues **may lead us to unduly influence a client's decisions** — through our words, actions or even unconscious behaviors.*

*You (as a family planning professional) do not need to give up or change your values and beliefs. **But you do need to identify any potential bias and build your personal strategies that will help prevent influence on your clients' decision making process.** The ability to separate our personal opinions from the client's decision making is the foundation to providing quality client-centered care.*

Thank you for your open and respectful participation in this activity.

**Wrap-Up
Activity 1.2 Complete**





Exploring our Personal Values Worksheet

This worksheet is confidential — you will not need to share it with anyone.

Please complete these sentence stems as quickly as possible. Write the FIRST thing that comes into your mind. Be brief — only a few words. Do NOT think too long about your answers.

- 1) The best method of birth control is....
- 2) A woman who uses emergency contraception repeatedly ...
- 3) A man who doesn't use a condom and says he doesn't want to be a dad ...
- 4) A woman who has six children ...
- 5) A woman who smokes and says she just can't afford birth control...
- 6) The ideal method of birth control for teenagers ...
- 7) The most risky method of birth control is ...
- 8) A woman who does not know if she wants to be pregnant ...
- 9) A woman who says — I just want a method that is natural ...
- 10) A woman who does not want to be pregnant and wants her IUD removed ...
- 11) People who use condoms every time they have sex ...
- 12) Using Natural Family Planning for contraception ...
- 13) When a woman is undecided about a birth control method, I would...

When you are done fold your worksheet in half to show that you are finished.



Being Client-Centered: A Self-Assessment

With each statement below think about 1 or 2 ways you demonstrate (verbally and/or nonverbally) this quality when working with your clients.

I understand and respect my client's rights.

I develop relationships with my clients using respect and kindness.

I understand the effect of nonverbal communication.

I encourage my client to ask questions.

I understand there are individual values, preferences and circumstances that affect a person's decision to use a particular contraceptive method.

I work to understand my own biases and prevent them from influencing the care I provide.

I actively listen and respond to my client's concerns.

I present information in a clear, easy to understand, balanced and unbiased, client-focused manner.

I recognize when I am not able to help my client and I have referrals available when I need them.

I place my clients' values and preferences foremost when providing contraceptive care and supporting them in choosing a method.



Activity 1.3 Principles for Providing Quality Counseling

Purpose

The purpose of this activity is to explore a contraceptive counseling process framework that includes a client-centered approach based on the Principles for Providing Quality Counseling. Staff will define the five principles and identify concrete examples of how to provide counseling that reflects these principles.

Who should participate?

Appropriate for all clinic staff who provide family planning services to clients

Especially important for staff who provide contraceptive counseling and education

Time

20-30 minutes

Preparation

Review the following:

- Module 1 Preview & Preparation
- Activity 1.3 Trainer Reference Notes
- Activity 1.3 PowerPoint Presentation
- Activity 1.3 Handouts

Materials

Handouts

Make one copy for each participant:

- Principles for Providing Quality Counseling
- Contraceptive Counseling Process Guide

Presentation

Load onto laptop and/or print slides as a handout for participants:

- Principles for Providing Quality Counseling

Supplies

- Large paper to stick/tape to the wall (at least 5 sheets)
- Markers
- (if available for presentation) Laptop, projector and screen

Resources

Have at least one printed copy available for reference:

- Providing Quality Family Planning Services (QFP): Recommendations of CDC and OPA, Appendix C
- Any agency policies or procedures that will support the client-centered, culturally inclusive services provided in your clinic setting

Detailed Instructions

1. Introduce the activity:

This activity will help us learn about and discuss the five key elements of the Quality Counseling Principles, based on the QFP. It provides us with a standardized client-centered framework that acknowledges each client's unique life experiences, goals and preferences.

2. Review the Key Concepts for Participants.

Optional: Post on large paper or white board.

The following Key Concept is the important takeaway for this activity.

- **The five key elements of Quality Counseling Principles, based on the QFP, provide a standardized client-centered counseling framework.**

And here are the key concepts that we covered in the previous two activities:

- *Client-centered counseling, respects each client's unique life experiences, reflects sound ethical health care practice, and helps ensure positive health outcomes for each client.*
- *Staff who provide contraceptive counseling have a professional commitment to work to prevent bias through self-awareness and by focusing on a client's needs and goals.*

3. Give each participant a copy of the Handouts:

- Principles for Providing Quality Counseling
- Contraceptive Counseling Process Guide

At a Glance

Introduction

Key Concept

The five key elements of Quality Counseling Principles (based on the QFP) provide a standardized client-centered counseling framework

Handouts

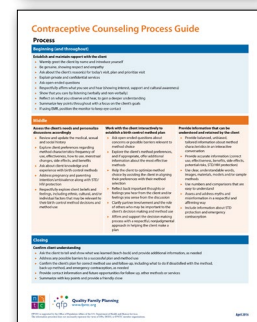



- 4. **Conduct the PowerPoint Presentation** (or use the slides handout), engaging participants in discussion of the content on each slide.

As we talk about the QFP Principles for Providing Quality Counseling — remember:

- Applying these principles is important for **individual staff** in their professional roles and interpersonal interactions with clients.
- These principles also have an **organizational perspective** — including administrative requirements such as established agency policies, procedures, staff orientation and training expectations are essential.

We'll focus on you (as an individual). We'll talk a bit about the organization later.

Let's take just a quick look at all five principles!

Can I have **five volunteers** to help me read the Principles out loud?

Now we'll go through each principle in more detail. Our first principal includes:

- Creating a **welcoming environment**
- **Building a relationship** of trust, respect and safety at every stage of the encounter, and
- **Ensuring confidentiality, expertise and easy access**

Think about yourself in your interactions with clients:

- 1) How do you (as a professional) do this?
- 2) What else would you include on this list?
- 3) What might be areas of improvement to apply this principle even more effectively in your work with clients?

Invite participants to share a few responses.

Keep thinking about these questions as we go through the next four principles.

Title Slide

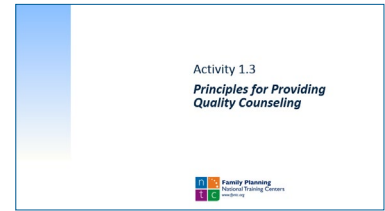

5 Principles for Providing Quality Counseling

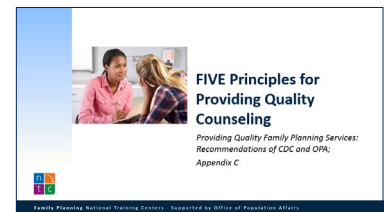

A Quick Look at all FIVE

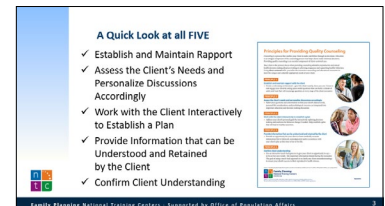

Establish and Maintain Rapport



This principle includes:

- **Gathering a client’s personal information** using standardized tools.
 - This will include a medical, social, and sexual history.
 - It may also include exploring psychosocial factors.
- Even when using standardized tools, you want to **tailor the discussion** to the client’s circumstances and needs
 - You might ask, “What’s the most important thing I can do for you today?”
- You want to **learn about the client’s** experience, values, beliefs, priorities, and goals which will be a reflection of their cultural experience.
 - We define culture broadly — it includes race & ethnicity, but also age, gender and gender identity, sexual orientation, economic class... and the many life experiences that are reflected in a person’s decisions.
 - **What other factors (influences) are part of a person’s culture?**
 - Each of us as individuals has our own cultural experience. **Our job when we are providing counseling and education is to learn about our client’s experience** — it is most certainly not just like your experience.
 - It’s important to never make assumptions.
 - You may want to say: “Clients who come here have many different experiences. Is there anything you would like to share with me about what’s important to you that would help me give you what you need today?”

This next principle includes:

- Using interactive counseling skills to **facilitate client-centered decision making**
- Identifying and **addressing possible misinformation (myths) and barriers** (access, etc.), and
- Creating an individualized plan based on the client’s needs and goals

Take a moment to think about how you do this; we’ll come back to this, so you may want to take notes for yourself.

Assess Client’s Needs & Personalize Discussions

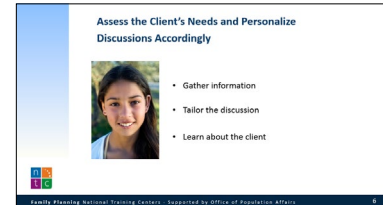

Work with the Client Interactively to Establish a Plan



For the next principle, it's important to:

- **Use interactive education strategies** to ensure informed decision making,
- **Use clear, understandable words, images, and materials,**
- **Tailor information to the client's needs and what they already know, and**
- **Use a medically accurate, balanced and nonjudgmental approach.**

Finally, for the last principle:

- **Use the teach-back method to ensure the client is making an informed and self-determined choice,**
- **Confirm the client's understanding and confidence in using the method(s) of choice, and**
- **Confirm a plan for follow up** based on the client's needs and possible challenges, such as if the client is dissatisfied with the method.

Here are all 5 Principles once again...

Adjust the following statement as needed depending on your agency's plans to provide training and feedback on these principles.

Our goal is to provide staff orientation and ongoing training and practice (with observation, coaching and feedback) to help staff continue to improve their skills.

Provide Info that Can Be Understood & Retained

Provide Information That Can Be Understood and Retained by the Client

- Use interactive education strategies to ensure informed decision-making
- Use clear, understandable words, images, and materials
- Tailor information to the client's needs and what they already know
- Use a medically accurate, balanced and nonjudgmental approach

Family Planning National Training Centers | Supported by Office of Population Affairs

Confirm Client Understanding

Confirm Client Understanding

- Use the teach-back method to ensure the client is making an informed and self-determined choice
- Confirm the client's understanding and confidence in using the method(s) of choice

Family Planning National Training Centers | Supported by Office of Population Affairs

Review — The Principles of Quality Counseling

Review — The Principles of Quality Counseling

- ✓ Establish and Maintain Rapport
- ✓ Assess the Client's Needs and Personalize Discussions Accordingly
- ✓ Work with the Client Interactively to Establish a Plan
- ✓ Provide Information that can be Understood and Retained by the Client
- ✓ Confirm Client Understanding

Family Planning National Training Centers | Supported by Office of Population Affairs

One way to use a client-centered contraceptive counseling approach is shown in the **Contraceptive Counseling Process Guide** that you have as a **handout**.

This process integrates all five principles into an easy to remember encounter process. It organizes the encounter into 3 stages — **Beginning, Middle and Closing**.

In the **Beginning** stage, you “set the stage” for establishing and maintaining rapport throughout the entire client encounter.

Toolkit for Training Staff Modules 1 and 2 focus on the “Beginning”

The **Middle** includes three principles. It focuses on the “personalized and interactive process” of learning about each client’s needs and goals, and providing clear, easy to understand and tailored information to assist each client in selecting a contraceptive method. These three principles don’t go in a specific order; they work together to support informed, client-centered decision making.

Toolkit for Training Staff Modules 3 and 4 focus on the “Middle”

The **Closing** applies the final principle to help you confirm the client’s understanding (using the teach back method) and make a plan (including follow-up) that will ensure the client’s success in their reproductive choices.

Toolkit for Training Staff Module 5 focuses on these final steps.

Discuss which staff are involved at each stage of this process in your agency.

Any other questions or comments on the five principles and the contraceptive counseling process before we move to the next part of this activity?

References & Resources and **Contact Information** are included at the end of each presentation

The Contraceptive Counseling Process

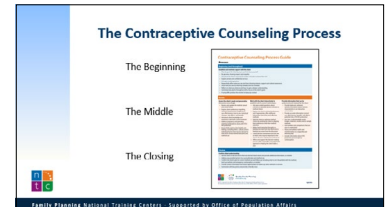

Questions/Comments

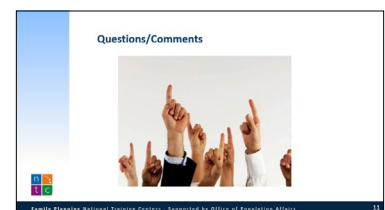

References & Resources and Contact Information

5. **Ask participants to form five groups**, one assigned to each principle
Give each group a large piece of **paper, tape and markers**.
Ask each group to write a different principle on the top of their large paper, and tape it to the wall.

Fewer than 10 participants?
You can do the following brainstorm all together as one group.

6. **Instruct the small groups to brainstorm around their principle:**

- *You'll have about 3 minutes at each principle. Start with the one your group wrote, brainstorming all **the ways you demonstrate that Quality Counseling Principle** in your work.*
- *You may also list **areas where you'd like to improve** how you demonstrate the principle.*

7. **Instruct the groups to rotate to the next principle**

After 3 minutes, call "switch" and have each group rotate to the next principle to add their ideas to this Principle list.

Give them just 2 minutes for this Principle. Continue until all groups have visited all principles, with 2 minutes or less at each.

Five Small Groups

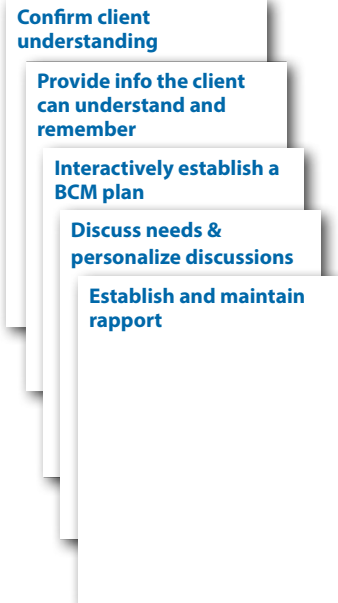

Principle Brainstorm

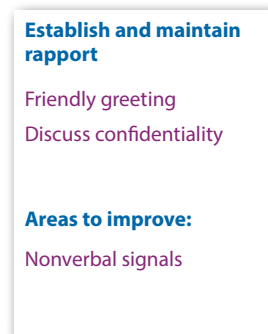

Rotate and Add Ideas

Each group gets ~2 mins at each principle to add their ideas



8. **Allow time for participants to walk around the entire room** after the rotations, so all participants can see the responses on all the papers.

9. **Lead a full group debrief**, asking participants to reflect and discuss:

- *How do you demonstrate these principles? How consistent are you?*
- *What are your challenges? What areas might you want to improve?*
- *What training or coaching would be helpful?*
- *What other resources, materials, or job aids would be helpful?*
- ***What are “next steps” for continued improvement in your skills?***

Encourage participants to write down their individual next steps.

Trainer Tip: Take notes of any next steps for the agency and share with leadership.

10. **Wrap up the activity**, sharing concluding/summarizing comments such as:

Using the principles of high quality, client-centered, culturally aware contraceptive services helps us provide the best care possible to clients to help them achieve personal goals.

*The **5 Quality Counseling Principles** and the **Contraceptive Counseling Process Guide**, outlined in your two **handouts**, will provide a standardized client-centered framework to help us ensure that our contraceptive services are consistently of the highest quality.*

Rotate and Read

Full Group Debrief

Reflect and discuss:

- What do I already do (and am I consistent)?
- What could I improve?
- What kind of training do I need?
- What are our next steps?

Wrap-Up Activity 1.3 Complete





Trainer Reference Notes:

Below are examples of possible strengths and areas for improvement for each of the 5 Quality Counseling Principles. Review these before the training, as examples, but don't necessarily describe these to the participants. Instead, explore and identify — with your own staff — examples that specifically fit your clinic.

Establish and maintain rapport with the client

Strengths	Challenges / Needs improvement
I try to always talk with clients in a private place	During busy times, privacy is hard
I'm trained on asking open-ended questions	I don't always have time for training, or have time to practice with colleagues
I talk about confidentiality and build trust	Teens worry we'll tell their parents if they come in

Provide information that can be understood and retained by the client

Strengths	Challenges / Needs improvement
I provide easy to understand printed materials for clients and in both English and Spanish.	It's hard when we have clients who don't speak English or Spanish and we don't have easy access to interpreters.
I review our materials to make sure I am accurate when I work with clients.	Printed materials are not always the best way to know for sure that the client understands.
I try to make sure education sessions and materials are culturally appropriate & reflect our clients' experience.	I don't always take time to check to see if our print materials work for my client.

Assess the client's needs and personalize discussions accordingly

Strengths	Challenges / Needs improvement
I ask questions to determine what else the client is concerned about, beyond their stated reason for the visit.	During busy times I don't always have time to spend with a client who has multiple problems.
I'm trained to provide client-centered services.	I don't practice, or ever observe anyone else



Work with the client interactively to establish a plan

Strengths	Challenges / Needs improvement
I'm good at making a plan with each client that is their plan.	I'm not sure how to use our standardized client education tools in a more personalized way.
I share resources and referrals for clients who want to make changes related to their health regarding smoking, substance abuse, diet, etc.	Clients may not want to change or access community resources.

Confirm client understanding

Strengths	Challenges / Needs improvement
I ask the client to explain to me what they understand.	Sometimes asking this question takes time I may not have at the moment.
I ask the client how their plan will work for them.	I may need to be better about making a follow up appointment to check on the client's plan.
I tell clients they can always call me later if they have questions or forget something.	Sometimes there is a lot of information in one clinic visit for a client to remember it all.



See Appendix C
for all other handouts
referenced in this activity.

Module 2: Client-Centered Communication Skills

Module Preview and Preparation

Key Concepts for Participants

1. Key elements of the OARS skills-based communication model will help build and maintain rapport, and help facilitate a discussion about each client's goals, needs, and preferences.
2. Proficiency and consistency in using these skills takes a willingness to listen, reflect, learn and practice.

About This Module

This module will review strategies for building rapport and trust and communicating effectively with clients. It introduces the OARS Model, a clear and concise framework to help improve communication skills.

This module addresses the **Quality Counseling Principle** included in the *beginning* section of the **Contraceptive Counseling Process Guide**:

Principle: Establish and maintain rapport with the client

Beginning (and throughout)
<p>Establish and maintain rapport with the client</p> <ul style="list-style-type: none"> ▶ Warmly greet the client by name and introduce yourself ▶ Be genuine, showing respect and empathy ▶ Ask about the client's reason(s) for today's visit, plan and prioritize visit ▶ Explain private and confidential services ▶ Ask open-ended questions ▶ Respectfully affirm what you see and hear (showing interest, support and cultural awareness) ▶ Show that you care by listening (verbally and non-verbally) ▶ Reflect on what you observe and hear, to gain a deeper understanding ▶ Summarize key points throughout with a focus on the client's goals ▶ If using EMR, position the monitor to keep eye contact

OARS and other rapport-building skills will also facilitate the *middle* section of the counseling process. Staff can use these skills to elicit patient preferences for contraception and conduct an interactive, client-centered counseling session, as will be covered in future modules.

Why This Module Matters

The OARS skills-based communication model provides tools for developing a relationship between a client and staff person, so that staff can effectively support client decision making. This module helps participants become more intentional in their communication in order to build trust and rapport with a client and engage that client in a conversation about their personal experiences, considerations, preferences and needs. Establishing rapport, including asking open-ended questions, has been shown to be associated with contraceptive continuation.



Important Terms

As you prepare to deliver this module, familiarize yourself with the following terms:

Rapport-building strategies may include:

- Warmly greeting the client by name and introducing yourself.
- Being genuine, showing respect and empathy.
- Asking about the client's reasons(s) for today's visit.
- Explaining and ensuring privacy and confidentiality.
- Encouraging the client to ask questions and share information.
- Showing you are listening (verbally and non-verbally).
- Using culturally appropriate gestures, eye contact, and body language.

OARS is a skills-based, client-centered model of interactive techniques. These skills include verbal and non-verbal responses and behaviors. OARS outlines the ways we can engage the client in a conversation about the client's life and goals through the use of:

- Open-ended questions,
- Affirming statements,
- Reflective listening, and
- Summarizing statements.

Refer to the instructional tool **OARS: Essential Communication Skills** for further explanation and brief examples of each of the four skills.

***Trainer Tip:** As you prepare to deliver this module, think of your own examples of how these skills and other techniques help you build rapport with a client and assess what the client needs that day.*



Training Activities in this Module

Activity 2.1 How to Establish Rapport (15–20 minutes)

Purpose: Participants will be able to describe the skills and strategies used to build and maintain rapport and a trusting relationship with a client, setting the stage for reviewing the OARS Model in Activity 2.2.

In this activity, you will:

- Describe the importance of using verbal and non-verbal communication to build rapport from the moment an encounter begins and maintaining it throughout the client interaction.
- Lead participants in exploring ways they welcome and establish rapport with clients.

Activity 2.2 The OARS Model — Essential Communication Skills (45 minutes)

Purpose: Participants will be able to describe the OARS communication skills that help build rapport and personalize counseling with clients, setting the stage for practicing these skills in Activity 2.3.

In this activity, you will:

- Introduce the OARS Model framework.
- Ask participants to give examples of each of the four skills and discuss how they support effective communication with clients.
- Review a Case Study that shows how the four skills fit together within a client interaction.
- Explore opportunities to build these skills through ongoing practice, reflection and feedback.

Activity 2.3 Communicating with Brilliance — Practicing Your Skills (45–60 minutes)

Purpose: Participants will be able to apply effective communication skills through direct practice interviewing a partner on a non-clinical topic and experience the perspective of the “client” as they’re being interviewed. This practice sets the stage for ongoing use of these skills in future modules.

In this activity, you will:

- Give participants an opportunity to practice using these communication skills interactively through a conversation with a participant partner.
- Give participants an opportunity to experience an intentional conversation and assess the skills being demonstrated.



General Guidance for All Activities:

- Suggested language for the trainer to say out loud is in italics and shaded. We encourage you to cover these points in your own words and add additional comments relevant to your site.

Example:

This activity is to help us step back and think about what “client-centered” really means and how it’s demonstrated when a person is making a very personal and important life decision.

- We encourage you to be creative with how you present the content within the activities. Have fun, and make it your own! While the content is evidence-based and should be delivered with fidelity, there are many training approaches you could use to help your participants engage with this content. See *Effective Teaching Methods* for ideas, or incorporate your own favorite training strategies!



Activity 2.1 How to Establish Rapport

Purpose

The purpose of this activity is to identify and explore the skills and strategies used to build and maintain rapport and a trusting relationship with a client.

Who should participate?

Especially important for all clinic staff because it is about basic communication skills, rapport building and establishing a welcoming and accessible clinic environment.

Time

15–20 minutes

Preparation

Review the following:

- Module 2 Preview & Preparation
- Activity 2.1 Handouts

Materials

Handouts:

Make one copy for each participant (or re-use copies printed for Module 1):

- Contraceptive Counseling Process Guide
- Principles for Providing Quality Counseling (optional)

Supplies:

- Large paper to stick/tape to the wall — **3 sheets**, labeled with “Look,” “Voice,” and “Beginning”
- Markers

Resources

Have at least one printed copy available for reference:

- Providing Quality Family Planning Services (QFP): Recommendations of CDC and OPA, Appendix C

Look

Voice

Beginning



Detailed Instructions

1. Introduce the activity:

*The purpose of this activity is to talk about how we welcome and develop rapport (both verbally and non-verbally) with our clients. We know that how we communicate with our clients is essential to providing high quality and consistent contraceptive services. This activity will give us a chance to talk about **how** we do this and will set the stage for talking about a communication model (called OARS) that gives us a short checklist on using communication skills and how to use these skills with intention.*

2. Lead a group brainstorm about specific ways to welcome a client.

Have participants call out responses to each of the questions in **bold**. (If participants are struggling to come up with ideas, you might also ask the bulleted questions underneath.)

Encourage specific responses. For example, if someone says “look welcoming,” ask, “Exactly, what does that look like?”

As participants respond, **take notes on the large papers** you prepared.

How do you look?

- Is your body relaxed?
- Do you smile easily?
- What mannerisms are you aware of that might distract? (e.g., hair twisting, leg bouncing, etc.)
- What does your face look like when you are concentrating?
- How would you describe your “professional” appearance?
- How do you show that you are listening? (e.g., nodding, appropriate eye contact, etc.)

How is your voice and voice tone? (in person and on the phone)

- Are you speaking clearly? Slowly, so others can understand you?
- Are you speaking gently and softly (confidentially)?
- Do you avoid using slang (e.g., “whatever...”)?
- Do you explain any abbreviations you use?
- How do you show that you are listening? (e.g., restating what you heard from the client)

How do you begin your client interaction? (in person and on the phone)

- How do you introduce yourself?
- What words of welcome do you use? (“How can I help you today?”)
- What questions do you ask?
- How do you ask these questions?
- How do you show respect?
- How do you build trust?

At a Glance

Introduction

Purpose:

- Developing rapport
- Verbal and nonverbal
- Communication is an essential part of high quality services

Brainstorm

How can you greet or welcome a client?

How do you look?

Look

How is your voice/tone?

Voice

How do you begin?

Beginning

3. **Lead a group discussion** about ways to assess and improve your rapport-building skills.

- *How can we — as individuals — assess how we’re building rapport through our nonverbal signals, our words and our voice tone, and the messages we communicate at the start of a client interaction?*
- *How can we — as a team — help each other improve our rapport-building skills? How can we give and receive feedback in this area?*

4. **Review the “Beginning” section of the Contraceptive Counseling Process Guide.**

Note that the bulleted list in that section includes rapport-building strategies like those the group just brainstormed, as well as skills related to the OARS model, which you’ll go over in the next activity.

Trainer Tip: Activity 2.2 **The OARS Model — Essential Communication Skills** will offer a simple framework of skills that can help participants build a trusting relationship with clients.

Ask participants:

Why do you think the Process Guide says that these communication skills are for the “Beginning (and throughout)”?

Pause for responses.

*Establishing rapport is something that is important for us to do intentionally at the beginning of a visit, and then continue to do throughout. If we take time in that first moment when a client walks in the door to **invest in the relationship** and build rapport, **that investment will pay off throughout the visit** as a client becomes more comfortable in sharing their needs and goals.*

However, it is possible to lose trust that you initially built, which is why it’s important to apply good communication skills throughout the visit to help maintain rapport and a trusting relationship.

5. **Wrap up the activity**, sharing summarizing comments such as:

*This quick activity was aimed at describing and clarifying the qualities and skills we use when greeting and welcoming our clients. **Could you each share with the group one specific way you intend to increase your skills in building rapport?***

Remember: our non-verbal actions and voice tone are an important part of effective communication.

Discussion

- How to assess and improve as an individual?
- How to assess and improve as a team?

Process Guide — “Beginning”

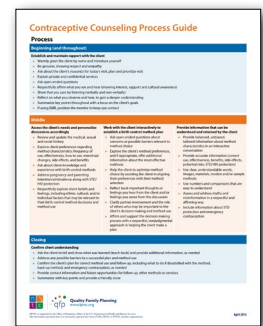

Why does the Guide say these communication skills are for “Beginning (and throughout)”?

Wrap-Up Activity 2.1 Complete





See Appendix C
for all other handouts
referenced in this activity.



Activity 2.2 The OARS Model — Essential Communication Skills

Purpose

The purpose of this activity is to help staff learn and apply OARS communication skills to build rapport and personalize counseling with clients, setting the stage for practicing these skills in Activity 2.3.

Who should participate?

Appropriate for all clinic staff who provide clinic services.

Especially important for staff who provide contraceptive counseling and education.

Staff who will participate in Activity 2.3 *Communicating with Brilliance — Practicing Your Skills* should participate in this activity if they are not familiar with the OARS Model.

Time

45 minutes

Preparation

Review the following:

- Module 2 Preview & Preparation
- Activity 2.2 PowerPoint Presentation
- Activity 2.2 Handouts

Materials

Handouts:

Make one copy for each participant:

- OARS Model: Essential Communication Skills
- OARS Cards Job Aid (*print on cardstock and laminate if possible*)
- Practice Worksheet for OARS

Presentation:

Load onto laptop and/or print slides as a handout for participants:

- The OARS Model: Essential Communication Skills

Supplies:

- (*if available for presentation*) Laptop, projector and screen
- Large paper to stick/tape to the wall or whiteboard (optional)
- Markers (optional)



Detailed Instructions

1. Introduce the activity:

The purpose of this activity is to learn about the OARS model and use this model as we assess our own skill level in how we offer a safe and welcoming environment and build and maintain rapport with each client.

In addition to helping to establish rapport, these skills can help us as we move through the contraceptive counseling process, helping us elicit client preferences for contraception and conduct an interactive, client-centered counseling session.

2. Review the Key Concepts for Participants.

(Optional: Post on large paper or white board.)

There are two Key Concepts for our activities on communication skills:

- *Key elements of the OARS skills-based communication model will help build and maintain rapport, and help facilitate a discussion about each client's goals, needs, and preferences.*
- *Proficiency and consistency in these skills takes a willingness to listen, reflect, learn and practice.*

We'll have several opportunities to practice these skills in this activity and the next; and every interaction you have with a client (or friend, or co-worker!) is always an opportunity to practice.

Trainer Tip: If you plan to go through Modules 3, 4 and 5 with the same group, note that these communication skills will come up in each of those modules.

3. Conduct the PowerPoint Presentation (or use the slides handout).

At a Glance

Introduction

Purpose:

- Learn OARS model
- Use OARS to assess our own communication skills

Key Concept

The OARS communication model will help build and maintain rapport, and facilitate discussion about each client's goals, needs and preferences

Proficiency and consistency in these skills takes a willingness to listen, reflect, learn and practice

Title Slide

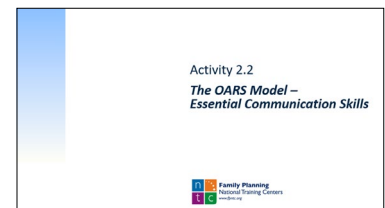

The model we will look at offers basic counseling skills that are easy to understand — but need practice, practice, practice.

These are skills and techniques that can be used the moment an encounter begins, and throughout the entire encounter to help build and maintain rapport.

Remember — rapport-building begins the moment your encounter begins. This may be on the telephone, at reception, when a session begins, and/or the moment a provider steps into an exam or consultation room.

The goal is to listen for the client’s goals and preferences and communicate with empathy, understanding and intention. With intention you can tailor your questions and your information to meet the client’s decision-making goals.

Who is familiar with the OARS Model? How about Motivational Interviewing (MI)?

Trainer Tip: The OARS model was developed by Miller and Rollnick in their MI approach, which is a larger framework outside the scope of this activity.

OARS is **a simple but comprehensive model** of communication that provides a framework for self-assessment & reflection aimed at improving our skills.

OARS is **a client-centered** model of key skills that will help you create an interactive encounter focused on the client’s goals, needs, and preferences.

How intentional are you with your communication skills?

Invite participants to share a few responses.

As we go through each of these skills, remember that they are used **throughout an encounter**; they will help you to elicit patient preferences for contraception and conduct an interactive, client-centered counseling session.

Also, remember that these skills include **both verbal and non-verbal** qualities and behaviors.

What are open-ended questions you ask clients (or patients)?

Invite participants to share a few responses. You may want to write them large paper or a whiteboard.

What are the reasons we want to ask open-ended questions?

Take a few responses before moving to the next slide.

Client-Centered Communication Skills

OARS Model

What are open-ended questions you ask...?



Ask for one or more volunteers to read the four bulleted reasons why we ask open-ended questions.

Open-ended questions can help you learn about your client's world. How can you better understand what they want, need, and how you might help?

One great over-arching question you may ask a client is: Is there anything you would like to share with me about what's important to you that would help me give you what you need today?

What are some of the positive things you say to clients?

And why are these affirmations important?

Take time for a brief discussion.

Ask a volunteer to read the two bulleted reasons why we offer affirmations to clients.

What are other ways we can offer our clients affirmations?

How hard is this to do? How much time does it take?

Affirmations don't have to take much time at all; the hard part is just remembering! Practice helps, and you can practice with one another.

Who has heard of "active listening"? What does "active listening" mean? (you're engaged, demonstrated with verbal and non-verbal behaviors, etc.)

Take time for a brief discussion.

*Reflective listening is a bit more specific. It is actually **reflecting out loud what you hear a person say**, in the words they use, such as: "... you said the irregular bleeding you're experiencing is really frustrating."*

Open-ended Questions

Open-ended Questions

- Building a trusting and respectful professional relationship
- Gaining an understanding about the client and the "client's world"
- Learning about the client's needs- today and possibly in the future
- Being more efficient (for you and for your client)

Family Planning National Training Centers - Supported by Office of Population Affairs

What affirmations...?

What affirmations do you offer clients (or patients)?

Family Planning National Training Centers - Supported by Office of Population Affairs

Affirming

Affirming

- Builds rapport; demonstrates empathy and trust that your client can make good decisions
- Affirms the client's strengths and abilities so you can build on them

Family Planning National Training Centers - Supported by Office of Population Affairs

What are the ways...?

What are the ways you use reflective listening?

Family Planning National Training Centers - Supported by Office of Population Affairs



Reflective listening also involves more than words; **it's also how they say it, or the emotion behind the words.** An example: "When you talked about having irregular bleeding, your voice got really strong. This must be really frustrating for you."

Reflective listening is also reflecting **what you see the client doing.** An example may be: "When you said you don't want to get pregnant right now, there were tears in your eyes..."

Reflective listening should be grounded in our desire to truly understand what is going on with a client. It can help us to not make assumptions about a client; if a client disagrees with a reflective statement you say to them, it's an opportunity to correct assumptions and improve understanding.

Using reflective listening to understand a client's words, feelings, and behaviors can also **save time and help you more quickly move to what is important for your client today.**

This is the heart and soul of counseling: helping the client see that you truly want to understand and help the client find the right pathway to a decision.

When do you summarize what your client has been saying?

Take time for a brief discussion.

Summarizing takes place both during and toward the end of a session. It's an opportunity to explicitly restate what's been said so far in the conversation.

It can help you move to a new topic, for example:

"So we've been talking about what's important for you right now — not getting pregnant and finishing school — and having birth control that really, really works! Shall we talk more about the methods that are really effective and easy to use?"

It's also a key step before moving to a plan of action, such as:

"We've talked about several methods and it sounds like you think an IUD might be a great choice for you. Tell me what you've heard are the most important points of using an IUD."

Reflective Listening

Reflective Listening

- Listening to what the client says, then briefly reflecting key words or phrases
 - To check accuracy and understanding
 - To show that you are listening
 - To help the client explore her/his own thoughts and feelings
- Observing the client's behavior (e.g. tears, smiles, etc.) and reflect possible feelings
 - Same as above
- Demonstrating your desire to understand the client's experience and needs

Family Planning National Training Centers | Supported by Office of Population Affairs

When do you summarize... ?

When do you summarize what your client has been saying?

Family Planning National Training Centers | Supported by Office of Population Affairs

Summarizing

Summarizing

- Transition - Reflecting what's been said so far and moving to a new topic
- Closing - Reflecting what's been said during the session and moving to a plan of action

Family Planning National Training Centers | Supported by Office of Population Affairs

Let's do a brief case study to practice the skills and to think about using the skills with a client.

Distribute the **OARS Model: Essential Communication Skills** hand-out and **OARS Card** job aid to each participant.

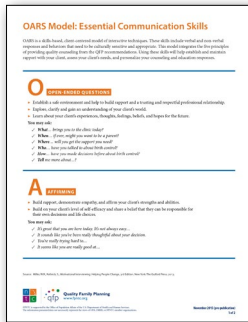

Case Study: Celine



Have one of the participants read the details about Celine.

Think for a moment how you might begin the session... what would you say and/or do?

Invite participants to share responses.

Case Study: Celine

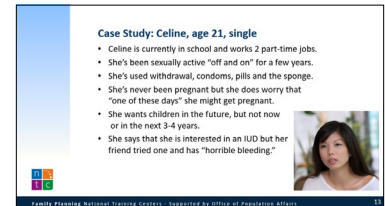

Have one of the participants read the dialogue box.

What skill is the provider using?

Invite participants to share responses.

The skill is affirming — letting Celine know that you understand that she is busy and capable.

Why is this important — what is your intent?

Invite participants to share responses.

This helps to build trust. You're acknowledging her busy world, affirming her planning, and showing respect for her effort.

How else can you provide her with an affirmation statement?

What is the skill?

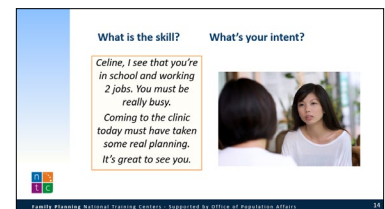

Have one of the participants read the dialogue box.

What skill is this? And what's the intent with using this skill?

Invite participants to share responses.

The skill is reflective listening — reflecting her words and her possible feelings, i.e., “worried?”

Doing this demonstrates understanding & empathy. Also, reflecting words, feelings, and/or behaviors can give you a chance to get to the “underneath” question or concern, checking your understanding and then digging deeper.

It's important to use reflections throughout an encounter, to:

- help keep you on track;
- help the client know what your focus is;
- help to clarify that your understanding is the same as your client's (be sure to ask the client to confirm!)

What else might you say?

Trainer Tip: People might say this is summarizing — and yes, it is. Reflective listening and summarizing are similar. The key difference is that reflective listening is usually not making a transition to another topic or closing the encounter.

Have one of the participants read the dialogue box.

What skill is the provider using? And what's the intent?

Invite participants to share responses.

This is an open-ended question. It can help you quickly learn about a client's experience, what method did (or did not) work, and more of what they know about birth control in general.

What else do you want to know about Celine? What are other open-ended questions that will explore, build rapport, or facilitate a decision making process?

What is the skill?

What is the skill? What's your intent?

You've told me you've used different methods of birth control and you haven't gotten pregnant.

It also sounds like you don't want to plan a pregnancy soon.

So you've been thinking about one of the long-acting methods of birth control.

But you're a bit worried about more bleeding with an IUD, which is one of the possible side effects.

Family Planning National Training Centers, supported by Office of Population Affairs 55

What is the skill?

What is the skill? What's your intent?

What birth control methods have you used in the past and how did they work for you?

Family Planning National Training Centers, supported by Office of Population Affairs 56

Have one of the participants read the dialogue box.

What skill is the provider using? And what's the intent?

Invite participants to share responses.

Summarizing is the skill, and the intent is to make explicit your understanding about what has been discussed or decided, and then transition into talking about other topics.

Summarizing is mostly reflective listening, with the purpose of making a transition to a new topic or the client's action plan.

The most important thing to remember is: It's the client's decision and the client's plan.

What else might you ask?

Do a quick review of the 4 essential skills.

Take a moment to think about which skills you feel comfortable and confident with, and what skills you'd like more practice with... would anyone like to share?

Getting comfortable in using these skills with intention takes lots of practice. I encourage you all to practice with a friend or a colleague. You could even record the practice with your phone and play it back to check out your skills.

Any other questions or comments?

References & Resources and **Contact Information** are included at the end of each presentation.

What is the skill?

What is the skill? **What's your intent?**

So Celine: we've talked about the various IUDs and how there might be some bleeding with an IUD, or at least a change in bleeding patterns, depending on which IUD you choose.

It also sounds like your periods are pretty light and you don't have many cramps. Your health history says you are a good candidate for an IUD. But you'd like to do some more thinking about what you want to do next... It is important to take time and feel right about it. (pause...)

So, what method might you use in the meantime - in case you need birth control?

You said you really don't want to get pregnant right now.

Family Planning National Training Centers, Supported by Office of Population Affairs

OARS Model

OARS Model: Using essential communication skills

- O = Open-Ended Questions
- A = Affirming
- R = Reflective Listening
- S = Summarizing

Family Planning National Training Centers, Supported by Office of Population Affairs

Questions/Comments

Questions/Comments

Family Planning National Training Centers, Supported by Office of Population Affairs

References & Resources and Contact Information

4. **Hand out the OARS Practice Worksheet.**

If you have time, give participants a few minutes to complete it on their own. Then review as a full group.

If you don't have time to review as a group, you may still hand this out, possibly as a homework assignment if you have another training session planned.

OARS Worksheet

OARS Practice Worksheet	
Open-ended questions – Change these closed questions into open-ended questions	
Do you use birth control regularly?	
Do you like your birth control method?	
Do you talk to your partner about birth control?	
Will you use condoms every time you have sex?	
Is it important that you don't get pregnant?	
Would you take a pill every day?	
Do you need protection from STDs?	
Do you care if anyone knows you are using birth control?	
Do you use alcohol or drugs?	
Are you good at keeping track of your periods each month?	
Affirming – What might be one affirming response to the statements below?	
I've never been here before.	
Sure, I use birth control sometimes...	
I know I should use condoms, but what a hassle.	
My girlfriend told me Daps would make me depressed, so I don't want to try that.	
My boyfriend pulls out – I haven't gotten pregnant yet!	
Reflective listening – What would be a reflective statement, reflecting feelings? Reflecting feelings? Remember you can also reflect a behavior, a smile, a frown, folded arms, etc.	
I've tried all these methods and I just hate using birth control. It's such a hassle.	
We've been talking about having a baby, I'm just not sure now is the right time.	
My husband thinks I should get on the pill.	
Using condoms just doesn't work for me.	
I've heard that getting an IUD will really hurt!	
I really care about my boyfriend, but I'm just not sure I want to have sex yet.	
I'm really tired of hormones in my body – I just don't like the way I feel.	
I'm just not good at taking a pill every day. I think I need something that works and I can just forget.	
I don't mind using condoms but my boyfriend just won't use them.	
It's ok – if it happens, it happens.	
Summarizing – Remember summarizing is a long "Reflective listening." When will you summarize?	

5. **Wrap up the activity.** In your own words, review these key messages:

- *The OARS skill-based communication model helps us build and maintain rapport, and personalize a client assessment of needs, goals and preferences.*
- *Proficiency and consistency in using these skills takes a willingness to listen, learn, practice, get feedback, **practice** some more, and — most importantly — grow your self-awareness and intention in using these skills.*

Trainer Tip: It is ideal to follow this activity with **Activity 2.3: Communicating with Brilliance — Practicing Your Skills**. This will give staff a chance to practice and get some feedback from a colleague.

**Wrap-Up
Activity 2.2 Complete**





OARS Practice Worksheet

Open-ended questions – *Change these closed questions into open-ended questions*

Do you use birth control regularly?	
Do you like your birth control method?	
Do you talk to your partner about birth control?	
Will you use condoms every time you have sex?	
Is it important that you don't get pregnant?	
Would you take a pill every day?	
Do you need protection from STDs?	
Do you care if anyone knows you are using birth control?	
Do you use alcohol or drugs?	
Are you good at keeping track of your periods each month?	

Affirming – What might be one affirming response to the statements below?

I've never been here before.	
Sure, I use birth control sometimes...	
I know I should use condoms, but what a hassle.	
My girlfriend told me Depo would make me depressed, so I don't want to try that.	
My boyfriend pulls out – I haven't gotten pregnant yet!	

Reflective listening – What would be a reflective statement; reflecting words? reflecting feelings? Remember you can also reflect a behavior; a smile, a frown, folded arms, etc.

I've tried all these methods and I just hate using birth control. It's such a hassle.	
We've been talking about having a baby, I'm just not sure now is the right time.	
My husband thinks I should get on the pill.	
Using condoms just doesn't work for me.	
I've heard that getting an IUD will really hurt!	
I really care about my boyfriend, but I'm just not sure I want to have sex yet.	
I'm really tired of hormones in my body – I just don't like the way I feel.	
I'm just not good at taking a pill every day. I think I need something that works and I can just forget.	
I don't mind using condoms but my boyfriend just won't use them.	
It's ok – if it happens; it happens.	

Summarizing – Remember summarizing is a long “Reflective listening.” When will you summarize?



See Appendix C
for all other handouts
referenced in this activity.



Activity 2.3 Communicating with Brilliance — Practicing Your Skills

Purpose

The purpose of this activity is to apply effective communication skills through direct practice interviewing a partner about a non-clinical topic.

Who should participate?

Especially important for staff who provide contraceptive counseling and education.

Participants should be familiar with the OARS Model or have participated in Activity 2.2.

Time

45–60 minutes

Preparation

Review the following:

- Module 2 Preview & Preparation
- Activity 2.2 PowerPoint Presentation
- Activity 2.3 Handouts

Materials

Handouts:

Make one half-sheet checklist for each participant (they will print two to a page):

- OARS Observer Checklist
- OARS Practice Instructions

Make one copy for each participant (or re-use copies printed for Activity 2.2):

- OARS Model: Essential Communication Skills
- OARS Cards Job Aid (print on cardstock and laminate if possible)

Presentation:

Optional — for review only (same presentation as Activity 2.2):

- The OARS Model: Essential Communication Skills

Supplies:

- (if available for presentation) Laptop, projector and screen
- Large paper to stick/tape to the wall, with discussion topics:
 - Where you want to go on your next vacation
 - Whether or not you want to get a pet
 - What you want to have for dinner
- Large paper to stick/tape to the wall, with prompts:
 - What's important for this person?
 - How is this person making their decision?

Where you want to go on your next vacation

Whether or not you want to get a pet

What you want to have for dinner

What's important for this person?

How is this person making their decision?

Detailed Instructions

1. Introduce the activity:

The purpose of this activity is to practice and identify which OARS skills are easy for you and which are more challenging. You will practice using the OARS skills to focus your questions, your affirmations, and your reflections on learning about your “client” — in this case, your colleague.

2. Create and post Group Agreements for this activity: (optional)

You may want to set Group Agreements to help participants feel safe and prepared to participate and share with other participants. Participants in the ‘client’ role should feel free to adapt what they say in the role to protect their privacy, if needed.

SAMPLE — Group Agreements

- ✓ Confidentiality (no stories, names or disclosures leave the room)
- ✓ Keep an open mind
- ✓ Be inclusive of each other
- ✓ Take care of your needs
- ✓ Have fun (as a team/group)!

3. Distribute copies of the OARS handout and job aid

Trainer Tip: Participants may already have copies if they received them in Activity 2.2.

4. Break participants up into groups of three.

Within each group, there should be:

- An interviewer
- A client
- An observer

Group members choose their own roles. The groups will do the practice exercise three times, switching roles each time, so that each person gets a chance to play every role.

Fewer than 6 participants? You can do this in pairs (eliminating the observer), or as a full group.

At a Glance

Introduction

Purpose:

- Practice using your OARS skills with a ‘client’ (colleague)

Group Agreements

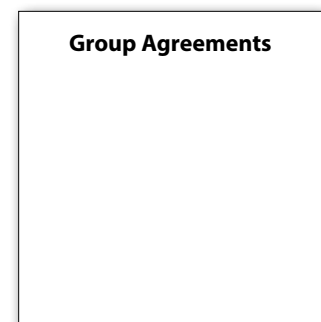

Handout, Job Aid

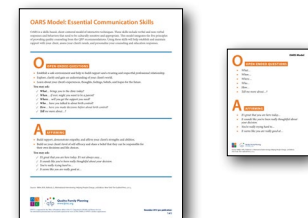

Groups of 3

Group members choose and rotate roles:

- Interviewer
- Client
- Observer

5. **Tell participants about the goal of the practice exercise.**

As an **interviewer**, your goal is to practice using OARS skills to learn about your client, keeping in mind these two key questions:

- What's important for this person?
- How is this person making their decision?

Trainer Note: These are the two key questions you wrote on a large piece of paper as part of your preparation of training supplies.

For those playing the **client**, this is an opportunity to explore how it feels when someone is asking and reflecting on what you are saying.

For those acting as the **observer**, you will see OARS in action and practice identifying the use of these skills within a conversation.

6. **Give a brief demonstration of the practice exercise.**

Invite someone from the group to volunteer to play the client, with you acting as the interviewer.

Ask the client to talk (briefly) about **where they want to go on their next vacation**, while you demonstrate how to ask open-ended questions, use affirmations, reflective listening and summaries in this context.

Trainer Tip: Feel free to use the OARS handout or job aid for reference as you do this quick demo! It can be a helpful resource for you, and will show participants how they can also look to the handout for ideas.

7. **Introduce the decision topics.**

Tell those participants who are playing the **client** in the first round of practice that they can select one of three decision topics:

- Where you want to go on your next vacation
- Whether or not you want to get a pet
- What you want to have for dinner

Practice Goal

What's important for this person?

How is this person making their decision?

Demonstration

- You play the interviewer
- Get a volunteer to play the client
- Volunteer talks about where they want to go on their next vacation
- You demonstrate OARS skills to learn more about the client

Demonstration

Where you want to go on your next vacation

Whether or not you want to get a pet

What you want to have for dinner

8. Hand out copies of the half-sheet OARS Practice Instructions and OARS Observer Checklist to each participant.

Review the instructions for each role, reminding participants that they will switch so that each person gets to play each role one time.

For the interviewers...

- Think about how you want to open and close your interview.
- What are some questions you might ask?
- How will you remember to listen for chances to offer affirmations?
- What reflections might you look for: face, body language, other?

For the clients...

- Only to disclose what you want to disclose. This is for practice only.
- Prepare to describe your reasons for making your decision.
- Pay attention to what it's like to be asked personal questions.
- Notice what the interviewer does that is effective.

When you are the observer...

- Use the Observer Checklist to take notes on the skills that are being demonstrated.
- Your role is to focus on the positive, sharing what you see that is helpful and successful.

9. Instruct the groups to start their first round of practice.

Allow 5-6 minutes for the practice interaction.

10. After 5-6 minutes, instruct the groups to debrief.

Ask each group of 3 to talk about what was helpful or challenging.

Allow 2-3 minutes for this small group debrief.

11. Instruct group members to switch roles, then do a second practice, with the new 'client' selecting the topic.

Ask the new 'clients' to select one of the three topics to discuss. They can discuss the same topic as the first 'client' if they wish.

For this second round, again allow 5-6 minutes for practice interaction, followed by 2-3 minutes for debrief within the small groups.

Practice Instructions & Observer Checklist

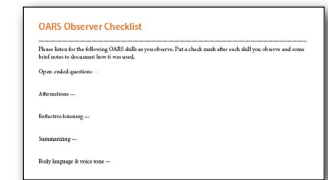
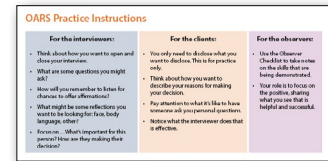

Practice — First Round

5–6 minutes

Small Group Debrief

What was helpful or challenging?

2-3 minutes

Practice — Second Round and Debrief

Group members switch roles

Practice: 5-6 minutes

Debrief: 2-3 minutes



12. **Instruct group members to switch roles one last time, and do the final practice and debrief.**

13. **Bring everyone back together for a full group discussion.**

Ask questions like:

- *How did your practice go?*
- *What was it like to be the client? What was effective? Did you learn anything?*
- *What was it like to be the interviewer? Did you try anything new? How did it go?*
- *What did you learn as the observer? What did you see that was really effective?*
- *Overall, which of the OARS skills is the easiest? Do you all agree?*
- *Which of the skills are more challenging to you?*
- *What would help you become more skilled and comfortable in effective and intentional communication?*

14. **Wrap up the activity.** In your own words, review these key messages:

Thank you for taking some risks today. When we practice, it can be a bit stressful. But the way we get better in our work is by taking the risk to change (or tweak) what we do when we work with clients.

The same skills you practiced today to learn about your “client’s” decisions related to vacations or dinner can be used within a contraceptive counseling visit, to help learn about what is important to your client as they make decisions about contraception.

How we communicate with clients — and each other — is important and is the foundation to quality client-centered counseling and education.

Practice — Third Round and Debrief

Group members switch roles

Practice: 5-6 minutes

Debrief: 2-3 minutes

Large Group Debrief

Wrap-Up Activity 2.3 Complete





OARS Practice Instructions

For the interviewers:

- Think about how you want to open and close your interview.
- What are some questions you might ask?
- How will you remember to listen for chances to offer affirmations?
- What might be some reflections you want to be looking for: face, body language, other?
- Focus on...What's important for this person? How are they making their decision?

For the clients:

- You only need to disclose what you want to disclose. This is for practice only.
- Think about how you want to describe your reasons for making your decision.
- Pay attention to what it's like to have someone ask you personal questions.
- Notice what the interviewer does that is effective.

For the observers:

- Use the Observer Checklist to take notes on the skills that are being demonstrated.
- Your role is to focus on the positive, sharing what you see that is helpful and successful.

OARS Practice Instructions

For the interviewers:

- Think about how you want to open and close your interview.
- What are some questions you might ask?
- How will you remember to listen for chances to offer affirmations?
- What might be some reflections you want to be looking for: face, body language, other?
- Focus on...What's important for this person? How are they making their decision?

For the clients:

- You only need to disclose what you want to disclose. This is for practice only.
- Think about how you want to describe your reasons for making your decision.
- Pay attention to what it's like to have someone ask you personal questions.
- Notice what the interviewer does that is effective.

For the observers:

- Use the Observer Checklist to take notes on the skills that are being demonstrated.
- Your role is to focus on the positive, sharing what you see that is helpful and successful.



OARS Observer Checklist

Please listen for the following OARS skills as you observe.

Put a check mark after each skill you observe and some brief notes to document how it was used.

Open-ended questions —

Affirmations —

Reflective listening —

Summarizing —

Body language & voice tone —

OARS Observer Checklist

Please listen for the following OARS skills as you observe.

Put a check mark after each skill you observe and some brief notes to document how it was used.

Open-ended questions —

Affirmations —

Reflective listening —

Summarizing —

Body language & voice tone —



See Appendix C
for all other handouts
referenced in this activity.

Module 3: Quality Education Strategies

Module Preview and Preparation

Key Concepts for Participants

1. Education is an integral component of the quality contraceptive counseling process.
2. Using effective education strategies helps you deliver accurate, balanced, nonjudgmental information to clients.
3. It's important to be able to explain the basic information of all contraceptive methods in a tailored, accurate, and easy to understand way.

About This Module

This module will include practice on how to educate clients about contraceptive methods, and address the common myths and misinformation that many people have about various methods.

This module addresses the **Quality Counseling Principle** included in the *middle* section of the **Contraceptive Counseling Process Guide**:

Principle: Provide information that can be understood and retained by the client

Middle		
<p>Assess the client's needs and personalize discussions accordingly</p> <ul style="list-style-type: none"> Review and update the medical, sexual and social history Explore client preferences regarding method characteristics: frequency of use, effectiveness, how to use, menstrual changes, side effects, and benefits Ask about client knowledge and experience with birth control methods Address pregnancy and parenting intention/ambivalence along with STD/HIV protection Respectfully explore client beliefs and feelings, including ethnic, cultural, and/or individual factors that may be relevant to their birth control method decisions and method use 	<p>Work with the client interactively to establish a birth control method plan</p> <ul style="list-style-type: none"> Ask open-ended questions about concerns or possible barriers relevant to method choice Explore the client's method preferences, and if appropriate, offer additional information about the most effective methods Help the client to optimize method choice by assisting the client in aligning their preferences with their method selection Reflect back important thoughts or feelings you hear from the client and/or feelings you sense from the discussion Clarify partner involvement and the role of others who may be important to the client's decision making and method use Affirm and support the decision making process with a respectful, nonjudgmental approach in helping the client make a plan 	<p>Provide information that can be understood and retained by the client</p> <ul style="list-style-type: none"> Provide balanced, unbiased, tailored information about method characteristics in an interactive conversation Provide accurate information (correct use, effectiveness, benefits, side effects, potential risks, STD/HIV protection) Use clear, understandable words, images, materials, models and/or sample methods Use numbers and comparisons that are easy to understand Assess and address myths and misinformation in a respectful and affirming way Include information about STD protection and emergency contraception

This principle incorporates effective education strategies and lists key topics that clients should know about regarding the method(s) they are considering.

While it is important for education to be tailored to each individual client's needs and decisions, **this toolkit covers education (Module 3) before assessment and interactive decision making (Module 4). This training approach aims to ensure that participants are able to describe basic information about the full range of birth control methods prior to practicing an interactive client centered decision making process.**

Why This Module Matters

Clinic staff must be able to explain the basic facts of a full range of birth control methods in a tailored, easy to understand way to ensure consistent and correct use of methods. Using evidence informed education strategies within the interactive client-centered contraceptive counseling approach will help clients make informed decisions and follow through on a family planning and reproductive health plan.



Important Terms

Education is an integral component of the client-centered counseling process that helps a client make informed decisions. It is a process of imparting or acquiring particular knowledge or skills through an interactive conversation between the client and provider.

Culturally appropriate and tailored education helps clients make decisions that reflect personal values, experiences, life circumstance and personal preferences. Contraceptive education must be:

- Medically accurate
- Balanced
- Nonjudgmental
- Presented in a simple and easy to understand manner

Refer to the instructional tool **Seven Strategies for Effective Education** for how to deliver accurate, balanced, nonjudgmental information in an interactive manner.

Trainer Tip: There is likely a range of knowledge and experience among your staff with regard to the various contraceptive methods. Try not to make assumptions about participants' knowledge; even trained and/or licensed staff may have misconceptions about (or limited familiarity with) certain methods. Assessing staff understanding of a full range of contraceptive methods and facilitating method updates, as needed, is very important to quality contraceptive counseling.

Additional Resources

Additional educational strategies are listed in the Resources and Reference Section.



Training Activities in this Module

Activity 3.1 Birth Control Information — Simple and Accurate (60 minutes or longer)

Purpose: Participants will be able to describe basic information, including a description of how a method works and the correct use of the method, effectiveness, potential menstrual and other side effects, and other considerations for each method of birth control.

In this activity, you will:

- Assess participants' knowledge level prior to the activity and provide homework as needed.
- Guide participants who are new to providing contraceptive services or need a refresher through a review of seven basic facts for each method of birth control. (Note: You may need multiple sessions to cover the full range of available birth control methods.)

Activity 3.2 Explaining Characteristics and Effective Use of a Method (45 minutes)

Purpose: Participants will be able to practice explaining characteristics and effective use of contraceptive methods with clients in an accurate, unbiased and client-centered way, using teaching tools and birth control samples.

In this activity, you will:

- Review a method chart tool with the group. We encourage use of a chart that presents a full range of birth control methods such as the one included with this activity.
- Review various method characteristics that may influence a client's choice of method.
- Demonstrate how to facilitate a discussion with a client about effective use of a method.
- Ask participants to practice in pairs how to use the birth control methods chart and other tools.

Activity 3.3 Birth Control — Myth Busting! (30 minutes)

Purpose: Participants will be able to elicit and address birth control questions and myths in a manner that is clear and concise, respectful, and tailored to the client.

In this activity, you will:

- Ask participants to practice answering the common questions about birth control, including clarifying misinformation and common myths about specific methods.



Activity 3.4 What are the Seven Strategies for Effective Education? (30-45 minutes)

Purpose: Participants will be able to identify ways to improve the delivery of education in their clinic setting using the seven strategies for effective education.

In this activity, you will:

- Ask participants to share sample statements and examples of what each of the seven strategies might look like during a client visit.

Activity 3.5 Applying the Seven Strategies to Contraceptive Education (60 minutes)

Purpose: Participants will be able to practice using tools and strategies to practice explaining select methods of birth control in a simple, accurate, easy to understand manner.

In this activity, you will:

- Group participants to practice integrating strategies for effective education, effective communications skills (Module 2), and knowledge of contraceptive methods in an interactive role play.
- Lead a debrief of the role play activity, emphasizing that learning how to provide client-centered, unbiased, contraceptive counseling and education takes time, training, and practice.



General Guidance for All Activities:

- Suggested language for the trainer to say out loud is in italics and shaded. We encourage you to cover these points in your own words and add additional comments relevant to your site.

Example:

This activity is to help us step back and think about what “client-centered” really means and how it’s demonstrated when a person is making a very personal and important life decision.

- We encourage you to be creative with how you present the content within the activities. Have fun, and make it your own! While the content is evidence-based and should be delivered with fidelity, there are many training approaches you could use to help your participants engage with this content. See *Effective Teaching Methods* for ideas, or incorporate your own favorite training strategies!

Novice/Beginner Notes

Does your training participant group include staff who are novices/beginners? These staff:

- Have no/limited experience in family planning
- Have no/limited knowledge of the full range of birth control methods, including understanding how the methods work, and related anatomy and physiology concepts
- Would benefit from a review of family planning basics and birth control method options

If your group includes these staff, we recommend assigning the following homework prior to Module 3:

1. Complete **Family Planning Basics** eLearning course, Lessons 2 and 3 (takes approx. 1 hour): <http://fpntc.org/training-and-resources/family-planning-basics>
2. Review **Explaining Contraception Job Aids** (included in this toolkit, or online with the eLearning course)

We also recommend you plan extra time for the activities in Module 3, to ensure adequate time to address the questions and solidify the knowledge of your novice/beginner participants.



Activity 3.1 Birth Control Information — Simple and Accurate

Purpose

The purpose of this activity is to help staff identify and describe basic information for each of the methods of birth control accurately, in a simple and easy to understand manner.

Who should participate?

Appropriate for any staff person who works in a family planning or reproductive health setting.

Especially important for staff who will be offering any contraceptive counseling or education.

Trainer Tip: It is critical that participants understand accurate information about all methods of family planning before participating in subsequent activities in Modules 3, 4 and 5.

Participants with limited knowledge about birth control methods, and related anatomy and physiology concepts, may benefit from additional preparation prior to participating in Activity 3.1. See the **Novice/Beginner Notes** in **Module 3 Preview & Preparation** for recommended homework to give participants an opportunity to assess and improve their basic contraceptive knowledge level.

Time

60 minutes or longer (varies with group size and knowledge level)

Preparation

Review the following:

- Module 3 Preview & Preparation, including Novice/Beginner Notes
- Module 1, Activity 1.2 My Professional Role vs. My Personal Values — Discussing birth control methods can bring up personal beliefs and potential bias about specific methods. Be prepared to discuss values and clarify the professional role of client-centered contraceptive counseling.
- Resource (optional) <https://www.guttmacher.org/sections/contraception.php>
- Activity 3.1 Handouts

Materials

Handouts:

Make one copy for each participant:

- Birth Control Method Options chart*
- Birth Control Information: Simple, Accurate and Complete worksheet

Make only one copy (each participant pair will review a different method):

- Explaining Contraception Job Aids
- Any other relevant, method-specific information you use at your site

Supplies:

- Samples (or photos) of each birth control method you will be reviewing
- Male and female anatomy charts (recommended)
- Menstrual cycle chart (optional)

Trainer Tip: It may be a challenge to cover each and every method during one training session, especially if participants start the activity with limited contraceptive knowledge. This activity can be repeated at a later date with other methods being addressed.

*You may use a different birth control method chart if the typical use effectiveness rates match those on the Birth Control Method Options chart.

Detailed Instructions

1. Introduce the activity:

The goal of this activity is to review birth control methods and practice describing, simply and accurately, basic information about each method.

As an example – a simple way to describe how a condom works: “It’s a thin sheath that fits over an erect penis and stops a pregnancy by stopping sperm from getting into a woman’s vagina.”

This will be a great time to ask questions you have about any of the methods. You will hear how others would answer questions about the different methods. This activity is not about going into health screening detail – only to help us all be prepared to discuss basic information.

2. Ask participants to form pairs (or small groups, if working with a larger number of participants).

3. Assign each group a method and hand out related materials.

Each pair or small group will have a different method that they will practice describing with each other. Give each group:

- the Explaining Contraception Job Aids for that group’s method
- a physical sample (or photo) of that group’s method
- individual copies of the Birth Control Method Options chart
- individual copies of the Birth Control Information worksheet

Also provide any other relevant, method-specific information you use at your site. Distribute male and female anatomy charts and/or menstrual cycle charts to groups as needed.

At a Glance

Introduction

Purpose:

- Review methods
- Practice describing basic info about methods, simply and accurately
- Answer your questions about how methods work

Form Pairs (or Small Groups)

Method Materials

Explaining Contraception Job Aids

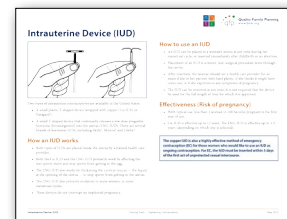

Sample of Method



Birth Control Method Options

Birth Control Info Worksheet

4. Provide a brief orientation to the Birth Control Method Options chart :

This chart briefly organizes the full range of methods by how each method is used related to perfect and typical user effectiveness. The typical effectiveness percentage for each method indicates the number out of every 100 women who experienced an unintended pregnancy within the first year of **typical use** of that method.

As you look at this chart of method options, remember there are also various characteristics (such as menstrual and other side effects) and a **range of effectiveness rates depending on how well a client can use the method**. Because of this range of characteristics for each method it's important to ensure that each client can decide which method will be the best method for them at this time. This chart should be used as part of an interactive, client-centered conversation, which is explored more in Module 4.

Trainer Tip: This activity is intended to only review “the facts” about birth control, but it can bring up personal beliefs and bias about some methods. See Module 1, Activity 1.2 about personal values and be prepared to clarify the professional role of client-centered contraceptive counseling.

5. Give the groups the following instructions:

- Review your method job aid and any samples or other information about your method
- Write the name of your method on your worksheet
- Discuss among yourselves how you would answer the first question about your method
- Write down your suggested answer to the first question on the worksheet, in a simple and easy-to-understand way
- Continue discussing and answering the rest of the questions on the worksheet

6. Allow 15-20 minutes for pairs (or groups) to finish their worksheets.

Check the groups’ progress as they work to ensure everyone is moving through the worksheet at a similar pace. If a group finishes quicker than expected, you might give them a new method to work on.

Explain Options Chart

- Full range of methods
- Organized by how methods are used, related to typical effectiveness
- Shows range of side effects and other considerations
- Important to use in interactive, client-centered way

Worksheet Instructions

- In pairs or small groups...
- Review info/materials related to your method
 - Discuss and complete Worksheet responses

Complete Worksheet

15-20 minutes

7. **Bring the large group back together and ask each pair/small group to present their method-specific answers to the full group.**

Encourage groups to present their answers in a creative way!

Invite feedback/questions after each group presents the simple answers for their method. Respond to questions and correct any misinformation.

8. **After all groups have presented, lead a full group debrief:**

Facilitate large group discussion, asking questions such as:

- Which birth control methods are easiest to describe? What makes them easier?
- What methods are hard to describe? What makes them harder to explain?
- What will you do to keep learning about the methods and practicing how to talk about them?
- Who is available to observe you and offer constructive feedback?

9. **Wrap up the activity**, highlighting the following points:

In order to provide any education or counseling on birth control methods it's really important to have up-to-date information about all methods, and to be able to explain this simply and completely. How can we all regularly update ourselves on advances and new information about methods as this becomes available?

*We've discussed basic information for methods, but remember that **each client will feel differently about the facts and features of each method.** Features of a method or its use may be a barrier for some clients and not others, and different characteristics will be more or less important for each client based on their experiences and preferences.*

Trainer Note: Participants will have opportunities to practice exploring barriers and determining preferences in Modules 4 and 5.

Presentations to Large Group

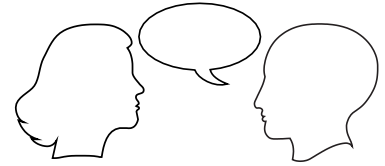

Large Group Debrief

- Which methods are easiest to describe? Why?
- Which methods are hardest to describe? Why?
- How will you keep learning and improving?

Wrap-Up Activity 3.1 Complete





Worksheet — Birth Control Information: Simple, Accurate and Complete

Review the method fact sheet and any other samples or materials for your assigned method. Write the name of the method below and discuss how you would answer each question in a simple and easy-to-understand way. Write your suggested answers in the spaces below.

Choose a member of your team to present your answers to the large group.

Specific Method: _____

	Key Questions	Simple and Easy-to-Understand Answer
<input type="checkbox"/>	How does it work?	
<input type="checkbox"/>	How do you use it? How often do you have to think about using it?	
<input type="checkbox"/>	What is typical user effectiveness? How might an individual's use of the method impact effectiveness?	
<input type="checkbox"/>	What are potential side effects (including menstrual side effects)?	
<input type="checkbox"/>	What are some of the benefits?	
<input type="checkbox"/>	What are potential health risks?	
<input type="checkbox"/>	Does this method give STD/HIV protection?	

Highly effective methods: Sterilization (male and female), long-acting reversible methods like the IUDs or implant

Following initiation of the method with a provider, there is little or nothing for the user to do or remember.

Moderately effective methods: Injectable (shot), pill, patch, ring, diaphragm

These methods require a prescription, and require the user to do something related to the method daily/weekly/monthly/every time they have sex.

Less effective methods: Condoms (male and female), fertility awareness based (FAB) methods, sponge, spermicides, withdrawal

These methods do not require a prescription and must be used every time you have sex/monitored daily.

Other methods: Abstinence, breastfeeding (Lactational Amenorrhea Method — LAM), emergency contraception (pills and copper IUD)

Female Anatomy

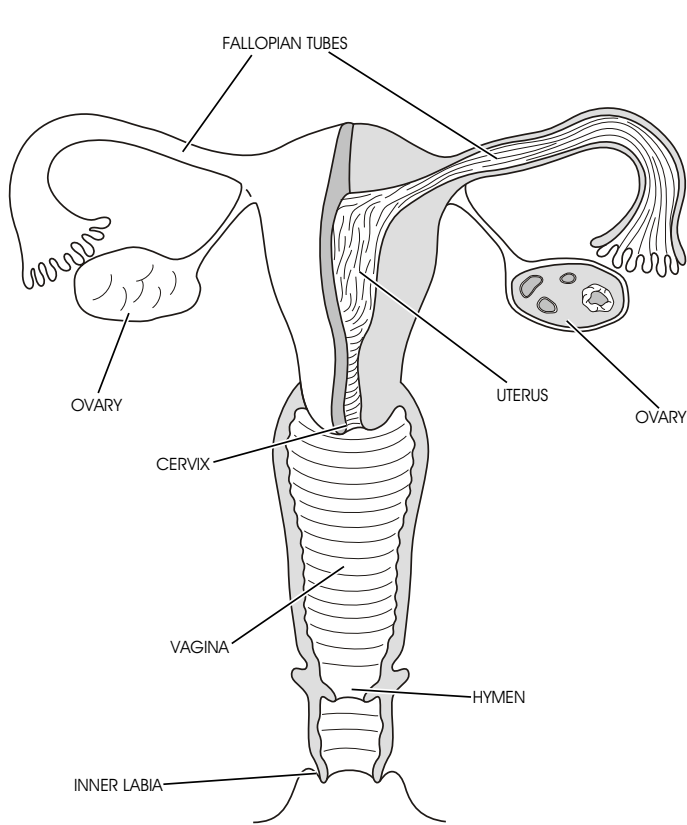

Front

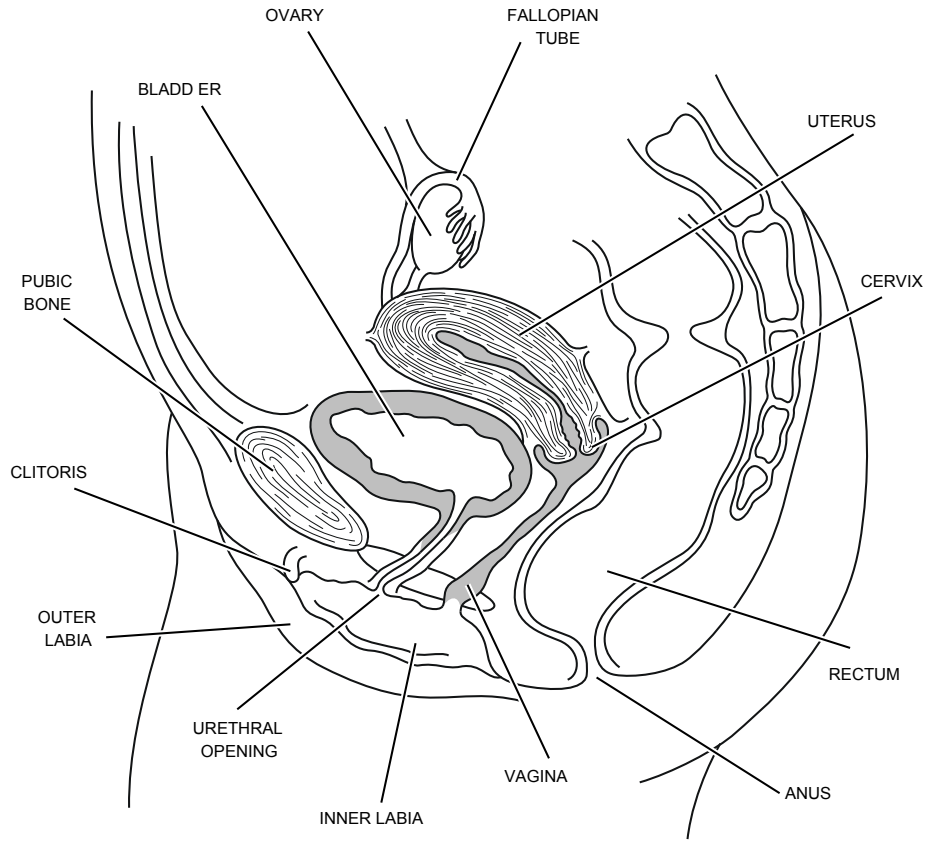

Side

Male Anatomy

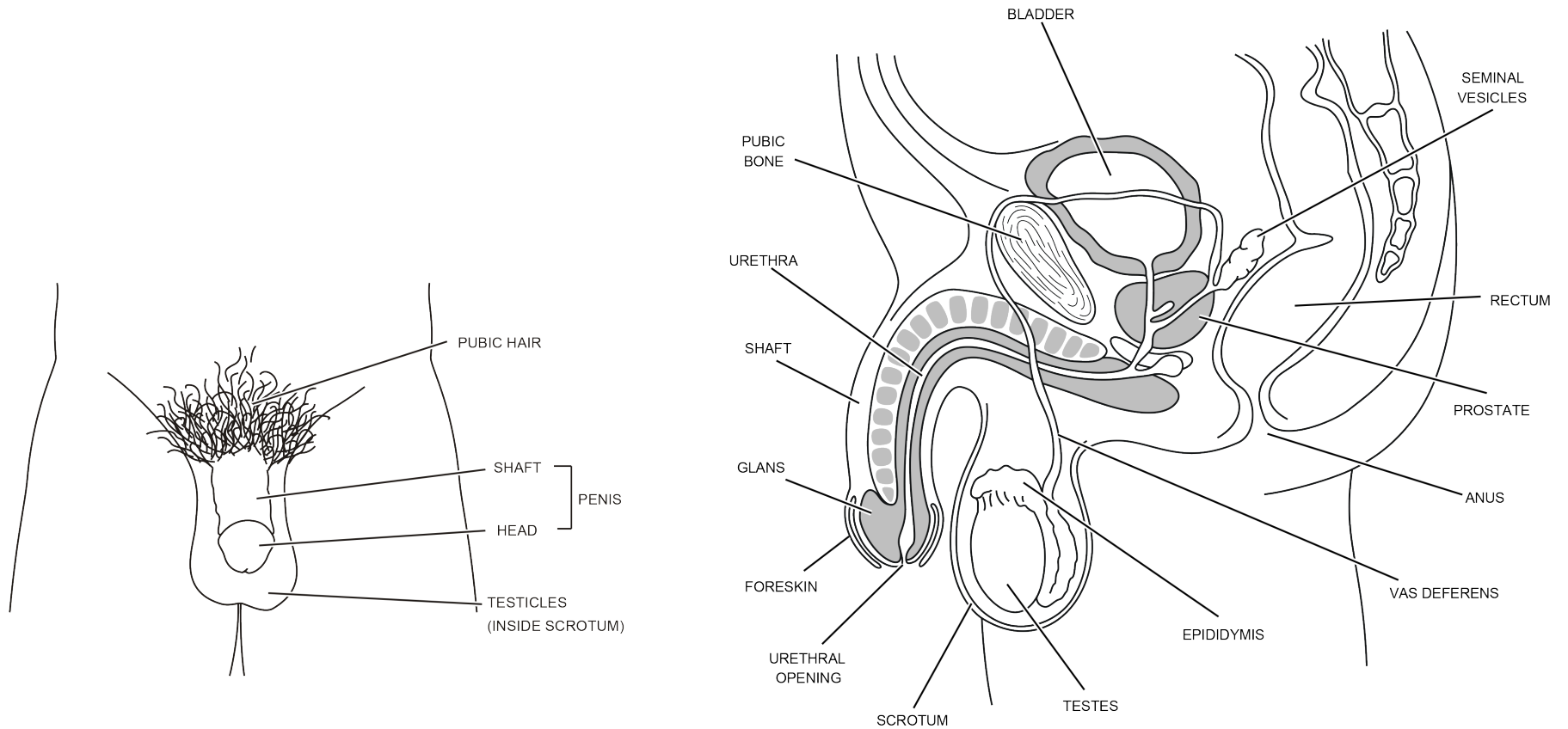

Front

Side



See Appendix C
for all other handouts
referenced in this activity.



Activity 3.2 Explaining Characteristics and Effective Use of a Method

Purpose

The purpose of this activity is to help staff practice explaining the characteristics and effective use of contraceptive methods with clients in an accurate, unbiased and client-centered way, using teaching tools and birth control samples.

Who should participate?

Appropriate for any staff person who works in a family planning or reproductive health setting.

Especially important for staff who will be offering any contraceptive counseling or education.

Time

45 minutes

Preparation

- Review the Module 3 Preview & Preparation
- Practice demonstrating a discussion of the characteristics and effective use of methods using the Birth Control Method Options chart and sample birth control methods (if needed).

Materials

Handouts:

Make **one copy for each participant** (or use copies printed for Activity 3.1):

- Birth Control Method Options chart*

Make **one half-sheet copy for each participant** (they will print two to a page):

- Characteristics and Effective Use Practice Instructions

Make **only one copy** (or use copy printed for Activity 3.1):

- Explaining Contraception Job Aids

Supplies:

- Samples of each birth control method for participants to use as teaching aids
- Male and female anatomy charts (recommended)
- Menstrual cycle chart (optional)
- Large paper to stick/tape to the wall or whiteboard (optional)
- Markers (optional)

* You may use a different birth control method chart if the typical use effectiveness rates match those on the Birth Control Method Options chart.

Detailed Instructions

1. Introduce the activity:

This activity builds on Activity 3.1, which focused on practicing how to discuss basic information about birth control methods in a simple and accurate way. This activity gives you a chance to practice talking with clients about the characteristics and the effective use of contraceptive methods, to ensure clients are fully informed about the full range of methods, the characteristics of different methods (including effectiveness), and how the methods compare to each other. Being able to discuss and compare methods is part of the interactive client-centered decision making process covered in Module 4.

Remember: Each client will differ in their ability to use various methods correctly and consistently, which impacts the effectiveness of any given method. Effectiveness is one of many factors clients may consider when deciding which birth control method they prefer to use; each method also has characteristics that include advantages and disadvantages for each client. When and how you talk about the basic information of birth control methods needs to be tailored to the client's interest.

2. Lead a brief discussion about the challenges of educating clients about various birth control methods:

(Optional: take notes on large paper or whiteboard.)

What are some of the challenges you might experience when talking with clients about different methods?

Invite participants to share a few responses. Be sure the following challenges are discussed:

- Clients may come to the visit with **myths or misinformation** about methods.
- It can be challenging to explain the difference between **'perfect use' vs. 'typical use.'**
- Clients may have varying levels in their ability to understand and work with numbers and may struggle with **understanding rates and percentages of effectiveness.**
- **Each client will differ in their ability to use various methods correctly and consistently,** based on a range of factors including remembering to take/use the method, or feeling comfortable with specific side effects.
- It can be challenging **to discuss risks and side effects in a balanced way,** respectfully addressing client concerns and not downplaying risks or side effects (even rare ones).

At a Glance

Introduction

Purpose:

- Practice talking with a client about the full range of methods, and how characteristics of different methods compare

Full Group Discussion: Challenges

Challenges:

- Myths/misinformation
- Perfect vs. typical use
- Explaining numbers, %s
- Different abilities to use methods
- Balanced discussion of risks and side effects

3. **Lead a brief brainstorm of strategies to increase client understanding of effective method use.**

(Optional: take notes on large paper or whiteboard.)

What are some strategies you can use when discussing effective use of a method with clients?

Invite participants to share a few responses. Be sure to discuss the following strategies:

- Help the client understand the **full range of birth control methods available** to them, now and throughout their lives.
- **Use simple comparisons** instead of complex absolute numbers, and **connect effectiveness to how the method is used**.
 - Using an IUD or implant for a year, less than one woman in 100 would get pregnant... because once the device is placed the woman doesn't have to do anything else, which means she'll be able to use it perfectly. Perfect and typical use numbers are about the same.
- Illustrate your main points with **simple charts or graphs with pictures**; some tools will help you to compare methods, others will offer in-depth information on a specific method.
- Show **physical samples of the method** when explaining how to use it/ how it works.
- **Discuss method characteristics such as side effects and/or other considerations** that may have an influence on a client's preference.
- Include a discussion about the client's ability to **use the method consistently and in the right way**, because this will impact how effective the method is for them.

4. **Distribute and review the Birth Control Method Options chart.**

Trainer Tip: You may also use a different chart that has the same typical effectiveness rates and shows the full range of methods.

In Activity 3.1, you used this chart as a tool to learn basic information about each method. Now we're going to practice using the chart in an interactive education conversation with a client.

When offering a broad range of methods, explain to your client that each of these methods is safe. It's also helpful for clients to easily see that methods have a range of effectiveness rates based on how the method is consistently and/or correctly used. You can explain that the most effective methods require little or no effort from the user once they are in place. You may also say that some people have a range of preferences about what is important to them in a birth control method.

- Who might use a chart like this when educating clients? When?
- How could you use this chart within a broader discussion of method characteristics and effective method use?

Full Group Discussion: Strategies

Strategies:

- Discuss full range
- Simple comparisons
- Connect effectiveness to how method is used
- Simple charts/graphs
- Samples of method
- Side effects, other considerations
- Discuss ability to use consistently & correctly

BCM Options Chart

The chart displays various birth control methods categorized by type (e.g., hormonal, barrier, long-acting reversible, permanent, natural). It includes columns for effectiveness rates (typical and perfect use), duration of use, and other characteristics. The chart is a comprehensive reference tool for comparing different contraceptive options.

5. **Ask for a volunteer to help you demonstrate how to use strategies and tools** to facilitate a discussion with a client about method options.

Provide a brief context before beginning your demonstration, such as:

You can always let your client know that all these methods are safe to use. If the client has identified a method they're interested in, focus on method use and effectiveness first, then compare it to other methods as appropriate. Discussing effectiveness (including typical vs. perfect use) may come after you've discussed factors of greater importance to the client, or it may be the first thing the client wants to know about. Let's assume this client has expressed an interest in birth control pills...

- Begin your demonstration by asking what the client already knows about pills.
- Ask the client what it would be like for her to take the pill every day, and at about the same time every day, and how that applies to the perfect vs. typical effectiveness rate.
- Use the Birth Control Method Options chart and other strategies to provide information on other methods and how comfortable the client would be in using the method consistently and correctly.
- Briefly demonstrate how to integrate information about how to use the method, the effectiveness rates, potential side effects, other considerations, and the health screening you provide to insure safety based on the client's health status.

6. Instruct participants to form pairs and hand out practice instructions.

Choose one person in your pair to play the role of the counselor, and one person to play the role of the client. In a few minutes, I'll ask you to switch roles.

The counselor should practice using the Birth Control Method Options chart and other strategies to provide education to your client on the characteristics and effective use of a method of your choosing.

*For those of you playing the role of the **client**, ask questions to help the counselor practice, and pay attention to what the counselor is doing that helps you gain an understanding of the method.*

7. **Tell participants to start their first practice.** (3-4 minutes)

Demonstration

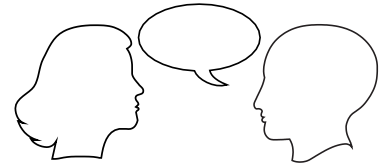

Pairs & Instructions

Choose roles: counselor and client

Characteristics & Effective Use Practice Instructions	
<p>For the counselors:</p> <ul style="list-style-type: none"> • Choose one of the methods listed at the top of the Birth Control Method Options chart. • Use the Birth Control Method Options chart, a sample of the method, Contraceptive Fact Sheet, and other strategies we've talked about to educate your client on the method. • Ask the client what they already know about the method. • Briefly explain how the method works, how it is used and the effectiveness based on perfect and typical use. • Very briefly describe some of the potential side effects and other considerations of the method. • If you finish early, choose a second method to practice with. 	<p>For the clients:</p> <ul style="list-style-type: none"> • "Role play" a client who has a little existing knowledge about the method the counselor has chosen. • Ask questions (remember: the point is to help the counselor practice, not quiz them). • Pay attention to what the counselor is doing that helps you gain an understanding of the method.

Practice 1



8. **Tell pairs to switch roles for the second practice.** (3-4 mins)

The new 'counselor' should pick a different birth control method.

9. **Bring the large group back together and debrief the activity.**

Ask questions such as:

- *How did it feel to be the client? What did the counselor do or say that was helpful to you?*
- *When playing the role of the counselor, what was challenging? What worked well?*
- *As the counselor, what was your experience using the chart? Any suggestions for improving your client-centered approach?*

10. **Share key points for using a client-centered approach when educating about method options:**

- *Begin in a client-centered way, by asking what the client knows, has heard about and/or is interested in with regard to birth control methods.*
- *Briefly address myths and misinformation the client may have, and respectfully offer additional, accurate information.*

Trainer Tip: Myths and misinformation are discussed in detail in Activity 3.3.

- *Remember that each client's circumstances and preferences will affect their ability to use a method consistently and correctly, making it more or less effective for that individual client.*
- *Always avoid coercion or undue promotion of a certain method.*

11. **Wrap up the activity,** highlighting the following points:

- *Our goal is to provide education on contraceptive characteristics including consistent and correct use and effectiveness that is clear, accurate, and tailored to the client.*
- *Another key aspect of client-centered care is respecting client's priorities and preferences. Talking with clients about how to choose the best method should always include asking what is most important for that client.*
- *Clients expect that a method is effective, but there may be other factors that are more important to that individual client.*
- *These and the other activities in Module 3 are all preparing you for Module 4, where you'll practice identifying what factors are most important to a client's choice of method, and then tailor your education approach accordingly.*

Switch Roles; Practice 2

Choose roles: counselor and client
"Counselor picks new method"

Large Group Debrief

- How did it feel to be the client?
- What was challenging or effective as the counselor?
- How was it using the chart and other tools?

Key Points: Education About Options

- Work from your client's knowledge and interests
- Respectfully address myths and misinformation
- Remember methods will be more or less effective for different clients
- Avoid coercion/promotion

**Wrap-Up
Activity 3.2 Complete**





Characteristics & Effective Use Practice Instructions

For the counselors:

- Choose one of the methods listed at the top of the Birth Control Method Options chart.
- Use the Birth Control Method Options chart, a sample of the method, Explaining Contraception Job Aids, and other strategies we've talked about to educate your client on the method.
- Ask the client what they already know about the method.
- Briefly explain how the method works, how it is used and the effectiveness based on perfect and typical use.
- Very briefly describe some of the potential side effects and other considerations of the method.
- If you finish early, choose a second method to practice with.

For the clients:

- "Role play" a client who has a little existing knowledge about the method the counselor has chosen.
- Ask questions (remember: the point is to help the counselor practice, not quiz them).
- Pay attention to what the counselor is doing that helps you gain an understanding of the method.

Characteristics & Effective Use Practice Instructions

For the counselors:

- Choose one of the methods listed at the top of the Birth Control Method Options chart.
- Use the Birth Control Method Options chart, a sample of the method, Explaining Contraception Job Aids, and other strategies we've talked about to educate your client on the method.
- Ask the client what they already know about the method.
- Briefly explain how the method works, how it is used and the effectiveness based on perfect and typical use.
- Very briefly describe some of the potential side effects and other considerations of the method.
- If you finish early, choose a second method to practice with.

For the clients:

- "Role play" a client who has a little existing knowledge about the method the counselor has chosen.
- Ask questions (remember: the point is to help the counselor practice, not quiz them).
- Pay attention to what the counselor is doing that helps you gain an understanding of the method.

Female Anatomy

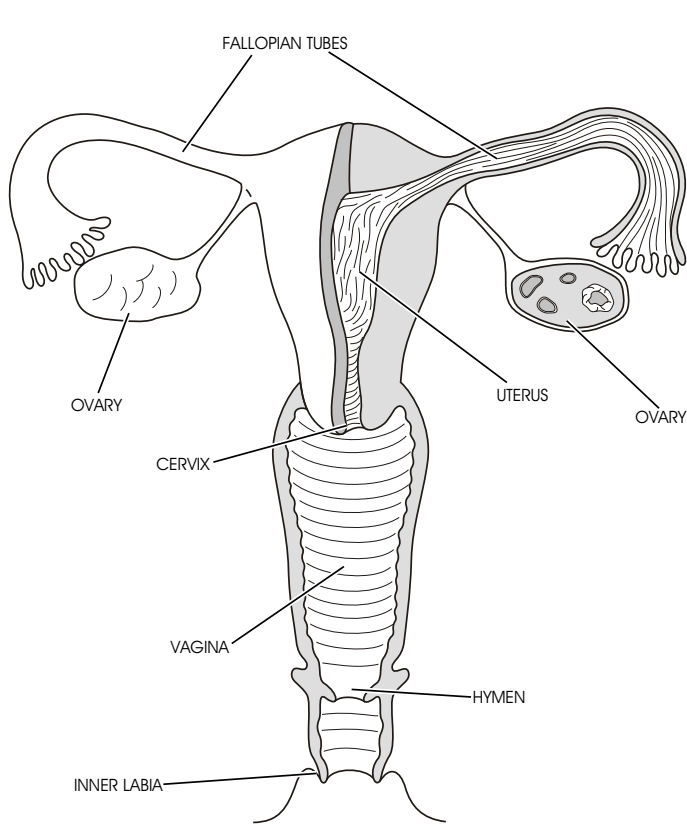

Front

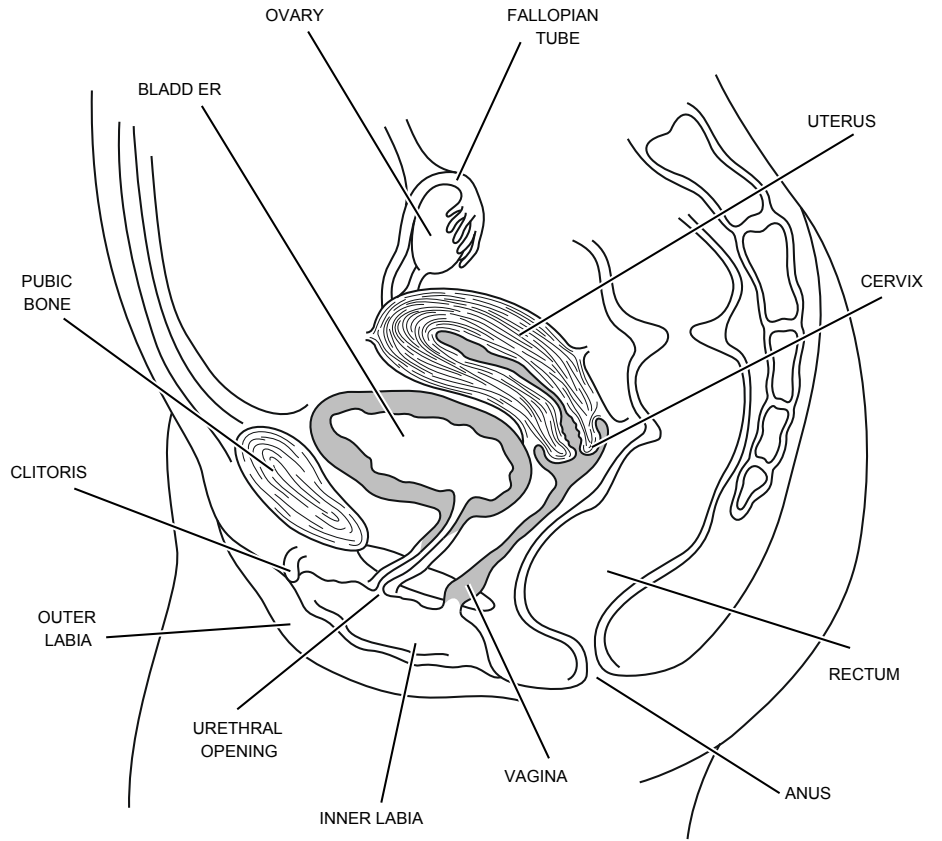

Side

Male Anatomy

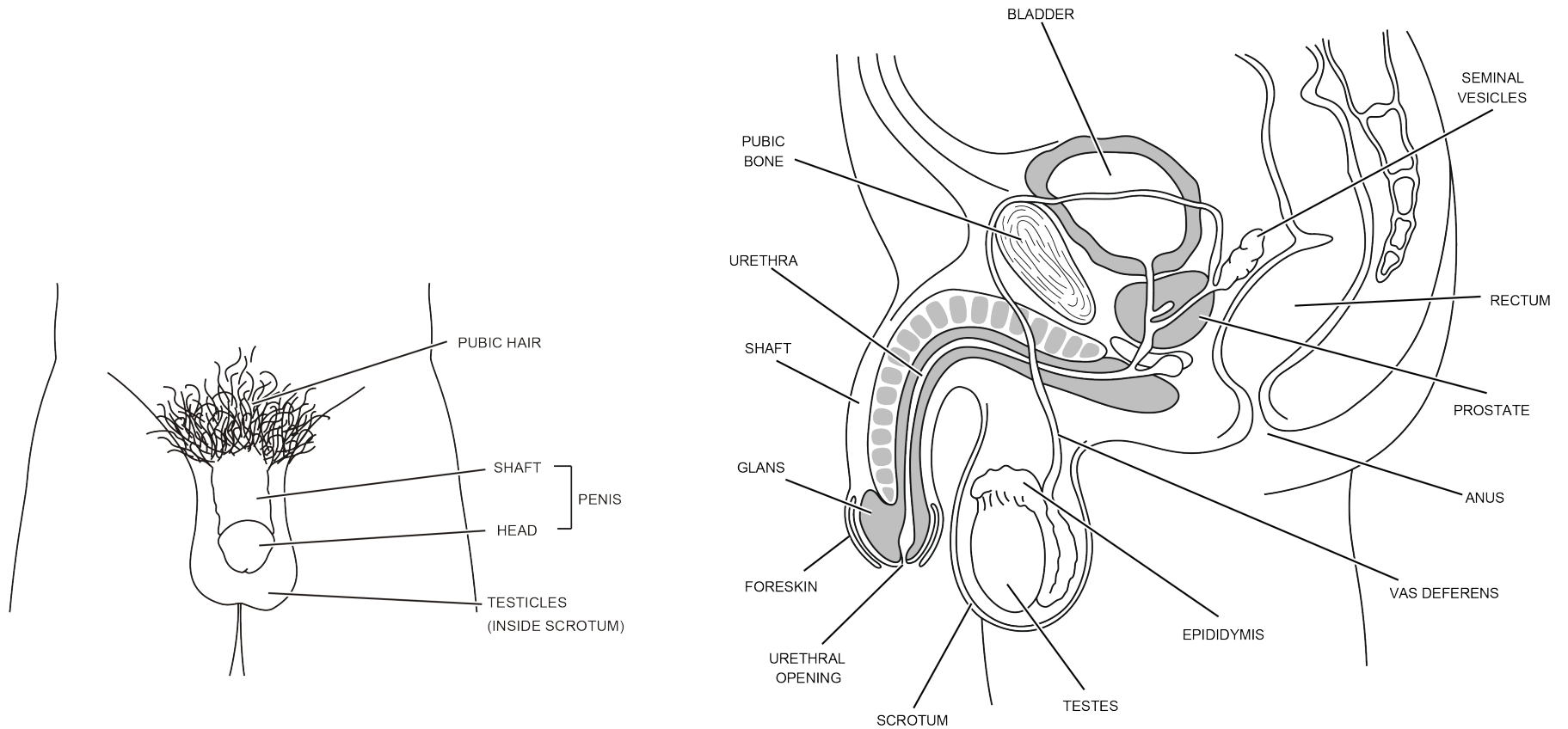

Front

Side



See Appendix C
for all other handouts
referenced in this activity.



Activity 3.3 Birth Control — Myth Busting!

Purpose

The purpose of this activity is to give staff practice in eliciting and addressing common birth control questions and myths in a manner that is clear and concise, respectful, and tailored to the client.

Who should participate?

Appropriate for any staff person who works in a family planning or reproductive health setting.

Especially important for staff who will be offering any contraceptive counseling or education.

Trainer Tip: To build participant confidence, be sure all participants have basic knowledge of each method of birth control, either by completing Activity 3.1 or through other training on birth control methods.

Time

30 minutes

Preparation

Review the following:

- Module 3 Preview & Preparation
- Activity 3.3 Trainer Reference Notes
- Activity 3.3 Myths and Misinformation Cards

Materials

Handouts:

Make **only one copy** (print single-sided); cut into squares and tape to 3x5 notecards

- Myths and Misinformation Cards

Make **one copy for each participant** (or use copies printed for Activity 3.1/3.2):

- Birth Control Method Options chart*

Make **only one copy** (or use copy printed for Activity 3.1/3.2):

- Explaining Contraception Job Aids
- Any other relevant, method-specific information you use at your site

Supplies:

- Supplies for participants to use as teaching aids:
 - Samples of each birth control method
 - Male and female anatomy charts (recommended)
- Large paper to stick/tape to the wall or whiteboard (optional)
- Markers (optional)

* You may use a different birth control method chart if the typical use effectiveness rates match those on the Birth Control Method Options chart.

Detailed Instructions

1. Introduce the activity:

This activity is a quick and fun way to practice how to respond to common birth control misinformation in a simple but accurate way.

There isn't just one way to answer these questions – tailor it to the person or client who is asking. base your answer on what they already know. The goal is to answer the question with expertise and provide reassurance that your information is based on facts and evidence.

2. Have each participant choose a myth/misinformation card.

Instruct participants to each pick a myth/misinformation card, and think about what they would say to a client who has this belief.

You only need to give a minute or two; the goal isn't to give a perfect answer, but simply to practice and get feedback from the group.

More than 10 participants? After everyone has picked a card, break participants into 2 or more groups for the next step.

3. Offer resources to help participants develop their response.

Invite participants to grab any of the following resources to help them develop and/or share their response to their card:

- Explaining Contraception Job Aids
- physical sample of the method
- Birth Control Method Options chart
- anatomy charts and/or menstrual cycle chart

At a Glance

Introduction

Purpose:

- Practice responding to common birth control myths/misinformation in a simple, accurate way

Myth Cards

- One per participant
- Think individually about how you might respond

#	Client Asks or States...
1	I think I'm sterile. I haven't used birth control much and I haven't gotten pregnant so I don't really need birth control.

Resources

Explaining Contraception Job Aids

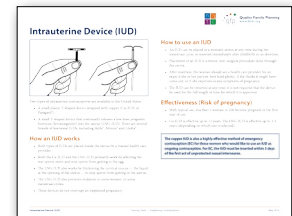

Sample of Method



Birth Control Method Options

Anatomy/menstrual cycle charts

(Use the tools you use in your clinic?)

4. **Have participants share their responses and receive feedback.**

Taking turns, each participant should:

1. Read their myth/misinformation card aloud to the group,
2. Share what they would say to a client with this belief,
3. Receive feedback from the group on the following points:
 - *What would you add?*
 - *What have you heard about this myth?*
 - *What is the key point for any response?*

5. **Lead a full group debrief** after every participant has had their turn.

Ask questions such as:

- *What is challenging about responding to these myths/misinformation?*
- *How can we talk about facts and evidence in ways that are clear and concise?*
- *What language can we use to address misperceptions in a respectful and positive way?*
 - *Examples: "That's a really common question." OR "I'm glad you brought that up...often people wonder about that."*
- *How can we get more comfortable addressing these topics?*

6. **Summarize key points for responding to myths/misinformation.**

(Optional: write on large paper or whiteboard)

- *When responding to a client's question, **first ask the person what they know**, or what they have heard, as a way of assessing knowledge or misinformation.*
- ***Consider where the misinformation they have may come from** (i.e., a parent, a friend, someone she or he trusts) before responding. Be respectful of that relationship.*
- ***Tailor your answer to the client, respectfully**, and when possible build on any truths the client has shared so far, related to the topic.*
- *Aim to **help the client understand and trust** your answer.*
- ***Be clear about your source of accurate information** and that your goal is to give the best, most up-to-date information for the client's contraceptive decision making.*
- ***Never be dismissive of reported side effects or problems** even if they are not documented in the evidence; remember that clients have diverse experiences with contraceptive methods.*

Sharing & Feedback

- Read card and response aloud to full group
- Get group feedback on the myth and the response

Full Group Debrief

- Read card and response aloud to full group
- Get group feedback on the myth and the response

Key Points

Addressing Myths / Misinformation:

- Find out what they know
- Consider where misinformation came from
- Tailor answer to client
- Be respectful
- Clear, trustworthy answer
- Be clear about your source
- Don't be dismissive



7. **Wrap up the activity.** In your own words, review these key points:

Thank you for practicing this skill! It takes some risk-taking to read these questions and answer in front of colleagues. But it's also helpful to hear ideas from others about how to respond in a way that is clear, accurate, and concise when a client states something that you know is incorrect. We all continue to practice these skills.

**Wrap-Up
Activity 3.3 Complete**





Trainer Reference Notes

The **Myths/Misinformation Cards** for participant practice include common client questions or concerns. Below are brief key messages for responses to each card. Blank cards are included in the **Myths/Misinformation Cards** sheet to for you to add your own questions, if desired.

Remind participants that it can be helpful to begin your response with an affirming statement such as, What a great question! or I hear that question often...

#	Client Asks or States...	Example Response
1	I think I'm sterile. I haven't used birth control much and I haven't gotten pregnant so I don't really need birth control.	I can understand how you may think you are sterile if you haven't used birth control and still haven't gotten pregnant. Sometimes it can take a while to get pregnant, even if you are trying to get pregnant — sometimes a year or even longer. So it is possible you could get pregnant even without using birth control every time.
2	I heard that a woman's sex drive goes down after she gets sterilized.	After a person has a sterilization procedure and is fully healed, the procedure itself should not have any effect on sex drive. Changes in sex drive can happen for many reasons. Sometimes sterilization has positive effect on the desire for sex because the worry about an unexpected pregnancy goes away. U.S. SPR 2013
3	Is it true that after a vasectomy, sperm will not be cleared from the man's tubes for at least a month?	It is true that after a vasectomy it takes time for the sperm to be cleared from the man's body. How quickly the sperm are cleared depends on how many ejaculations he has after the vasectomy. A semen analysis is done to ensure there is no semen in the ejaculate. A man should use other contraception (or abstain) until he has the confirmed semen analysis. U.S. SPR 2013
4	So if a woman has had a sex infection or if she's never been pregnant, she shouldn't get an IUD — right?	We now know — because of the latest research — that a woman who has had a "sex infection" or a sexually transmitted infection (or STI) in the past can get one of the modern IUDs. If a woman has an STI at the time of the insertion, she needs to be treated immediately, so STI screening is usually done before insertion. The latest research shows that if a woman has never been pregnant a modern IUD is safe. U.S. SPR 2013
5	I don't think I want an IUD — I hear it can move around and get lost in your body.	Very rarely, an IUD can be pushed through the uterus during insertion, but once it is properly placed, it doesn't move from the uterus. Let's look at this diagram (teaching aid) of a woman's reproductive system. It can show you where the IUD is placed.
6	My aunt told me that teens can't get an IUD — it's not safe.	Your aunt is remembering that in the past teens were not always offered an IUD as birth control. But — because of recent research with newer IUDs — we know that it is now a very safe method for almost all women including teens. U.S. SPR 2013



#	Client Asks or States...	Example Response
7	So if I get the implant — that means I have to leave it in for 3 years.	With methods like the implant — and IUDs — these methods that can be effective for a long time, but a woman can still have them removed anytime. There is no rule (requirement) that you have to keep them in place for the entire time they are effective.
8	I heard that the shot stays in your body for a while so if I'm a bit late I won't get pregnant right away anyway.	<p>The Depo shot is very effective as birth control and some women do have a delay in return to fertility where the effect of the Depo lasts longer than 13 weeks. But there is no way of knowing which women will have a delay. If you are late with getting your next shot you can't be sure you will not get pregnant. We do see some women who get pregnant right away at the end of the 13 weeks.</p> <p>We strongly recommend — if you don't want to be pregnant and are using the shot — be sure to get your next injection on time (every 13 weeks). How can we help make that easier for you?</p>
9	I've been taking pills for a few years now - I heard that I need to "give my body a rest" and stop for a while.	Many women take the pill for years and we have results of research on pills for over 50 years. So we know that you do not need to stop the pill to "give your body a rest." The pill is really safe for most women and it's most effective when you take it every day at about the same time every day - without stopping.
10	I don't take the placebo pills so I don't have my period — but I'm thinking maybe every few months I should stop them and have a period.	<p>Taking the hormone pills continually is a common practice these days and is not a health risk. Many women like not having a "period," and there is no medical need to stop the hormone pills.</p> <p>Some women may find it beneficial to stop the hormone pills once in a while to have a period as a way to control spotting that sometimes occurs with continuous use. If you stopped taking the hormone pills for longer than the length of time you would take the placebo pills, the risk of getting pregnant would go up.</p>
11	My mom says pills cause cancer so I shouldn't take them.	<p>During the past decades since the pills became available there has been a lot of research — and no evidence that pills cause cancer of any kind. In fact, there is evidence that taking pills can be a protective factor in some cancers and has other benefits.</p> <p>We do know that women who have some types of cancer should not take pills.</p> <p style="text-align: right;">U.S. SPR 2013</p>
12	I like to swim but I'm afraid my patch will fall off.	<p>The patch was designed to stay on your skin for 7 days — it should not fall off when you swim or take a shower or just get it wet.</p> <p>If a patch does fall off for less than 48 hours, put it back on. If it won't stay on, then apply a new one.</p>
13	My boyfriend thinks he can feel my ring. Can I take it out when we have sex?	Some people have said they can feel the ring during intercourse. It is ok to take it out for up to 3 hours in any 24 hour period without needing a back-up method to prevent pregnancy. You can then put the same ring back in place.



#	Client Asks or States...	Example Response
14	I hear the shot makes you fat.	<p>The Depo shot is a safe and effective method for most women. Some women gain weight with Depo, but most do not — it's pretty rare.</p> <p>We can help monitor any weight changes for you if you decide to use the Depo shot for birth control. How would you feel about any possible weight gain?</p>
15	So if a condom is good — using 2 condoms must be better protection.	<p>It seems like that would be right — but it actually isn't. Although, it's a common question we get.</p> <p>The reason it's not a good idea is that the 2 condoms (2 male condoms or 1 male and 1 female condom) is that the 2 might have friction (rubbing) between them and then tear. Just not a good idea for effectiveness.</p>
16	What happens if I can't get the ring out?	<p>We can help ... anytime. We get phone calls sometimes when a person can't get the vaginal ring out (or a tampon). We usually coach them through — get in a comfortable position, take a deep breath, relax her abdominal area, and then bare down. It usually works. If it doesn't work, you can always come into the clinic. We are here to help.</p>
17	How many times can I have sex and use just 1 sponge?	<p>When you put the sponge in your vagina it's effective for 24 hours and you can have sex as many times as you want. The main thing to remember is you have to leave it in place for 6 hours after the last time you have sex. So if you have sex when it has been in for 24 hours — wait for another 6 hours before you take it out.</p>
18	My religion doesn't believe in birth control — what do I need to know about my body so I don't get pregnant?	<p>So it seems like your question is about your monthly cycle of fertility — for example, when would you most (or least) likely get pregnant? There are several ways to learn about a woman's cycle based on fertility awareness. I have this basic chart of a menstrual cycle (teaching aid). Would you like to learn more about these very specific signs and symptoms and ways to track your menstrual cycles / your cycle of fertility?</p>
19	Everyone says that withdrawal doesn't work.	<p>Withdrawal effectiveness depends largely on the man's ability to withdraw his penis before he ejaculates. If a man is less experienced with using withdrawal or has a hard time knowing when he will ejaculate, there could be more chance of failure.</p>
20	Spermicide protects against STDs and HIV — right?	<p>It does sound like "spermicide" might protect against STDs — but in fact the spermicide stops sperm but not sexually transmitted infections or HIV. In fact, frequent use of spermicides (more than 2 times a day) can cause some vaginal irritation in women and may increase the transmission risk of an infection and HIV.</p>
21	How effective are emergency contraceptive pills? Maybe I should just use them.	<p>Emergency contraception is mainly for "emergencies" and there is a range of effectiveness. EC pills are not as effective as other methods and they are not recommended for ongoing use.</p> <p>Another emergency contraceptive is the copper IUD. It is very effective as an emergency method plus it has the added benefit of remaining as the method of birth control.</p> <p>When you think of birth control — what is most important for you in a method?</p>



#	Client Asks or States...	Example Response
22		
23		
24		



Myth Busting Practice Cards — Print and cut into individual cards (optional: tape/paste onto notecards)

<p>1 Client asks or states: I think I'm sterile. I haven't used birth control much and I haven't gotten pregnant so I don't really need birth control. <i>Activity 3.3 Birth Control – Myth Busting!</i></p>	<p>2 Client asks or states: I heard that a woman's sex drive goes down after she gets sterilized. <i>Activity 3.3 Birth Control – Myth Busting!</i></p>
<p>3 Client asks or states: Is it true that after a vasectomy, sperm will not be cleared from the man's tubes for at least a month? <i>Activity 3.3 Birth Control – Myth Busting!</i></p>	<p>4 Client asks or states: So if a woman has had a sex infection or if she's never been pregnant, she shouldn't get an IUD — right? <i>Activity 3.3 Birth Control – Myth Busting</i></p>
<p>5 Client asks or states: I don't think I want an IUD - I hear it can move around and get lost in your body. <i>Activity 3.3 Birth Control – Myth Busting!</i></p>	<p>6 Client asks or states: My aunt told me that teens can't get an IUD - it's not safe. <i>Activity 3.3 Birth Control – Myth Busting!</i></p>
<p>7 Client asks or states: So if I get the implant - that means I have to leave it in for 3 years. <i>Activity 3.3 Birth Control – Myth Busting!</i></p>	<p>8 Client asks or states: I heard that the shot stays in your body for awhile so if I'm a bit late I won't get pregnant right away anyway. <i>Activity 3.3 Birth Control – Myth Busting!</i></p>
<p>9 Client asks or states: I've been taking pills for a few years now - I heard that I need to "give my body a rest" and stop for awhile. <i>Activity 3.3 Birth Control – Myth Busting!</i></p>	<p>10 Client asks or states: I don't take the placebo pills so I don't have my period - but I'm thinking maybe every few months I should stop them and have a period. <i>Activity 3.3 Birth Control – Myth Busting!</i></p>
<p>11 Client asks or states: My mom says pills cause cancer so I shouldn't take them. <i>Activity 3.3 Birth Control – Myth Busting!</i></p>	<p>12 Client asks or states: I like to swim but I'm afraid my patch will fall off. <i>Activity 3.3 Birth Control – Myth Busting!</i></p>
<p>13 Client asks or states: My boyfriend thinks he can feel my ring. Can I take it out when we have sex? <i>Activity 3.3 Birth Control – Myth Busting!</i></p>	<p>14 Client asks or states: I hear the shot makes you fat. <i>Activity 3.3 Birth Control – Myth Busting!</i></p>



15	Client asks or states: So if a condom is good - using 2 condoms must be better protection. <i>Activity 3.3 Birth Control – Myth Busting!</i>	16	Client asks or states: What happens if I can't get the ring out? <i>Activity 3.3 Birth Control – Myth Busting!</i>
17	Client asks or states: How many times can I have sex and use just 1 sponge? <i>Activity 3.3 Birth Control – Myth Busting!</i>	18	Client asks or states: My religion doesn't believe in birth control - what do I need to know about my body so I don't get pregnancy? <i>Activity 3.3 Birth Control – Myth Busting!</i>
19	Client asks or states: Everyone says that withdrawal doesn't work. <i>Activity 3.3 Birth Control – Myth Busting!</i>	20	Client asks or states: Spermicide protects against STDs and HIV - right? <i>Activity 3.3 Birth Control – Myth Busting!</i>
21	Client asks or states: How effective are emergency contraceptive pills? Maybe I should just use them. <i>Activity 3.3 Birth Control – Myth Busting!</i>	22	Client asks or states:
23	Client asks or states:	24	Client asks or states:

Female Anatomy

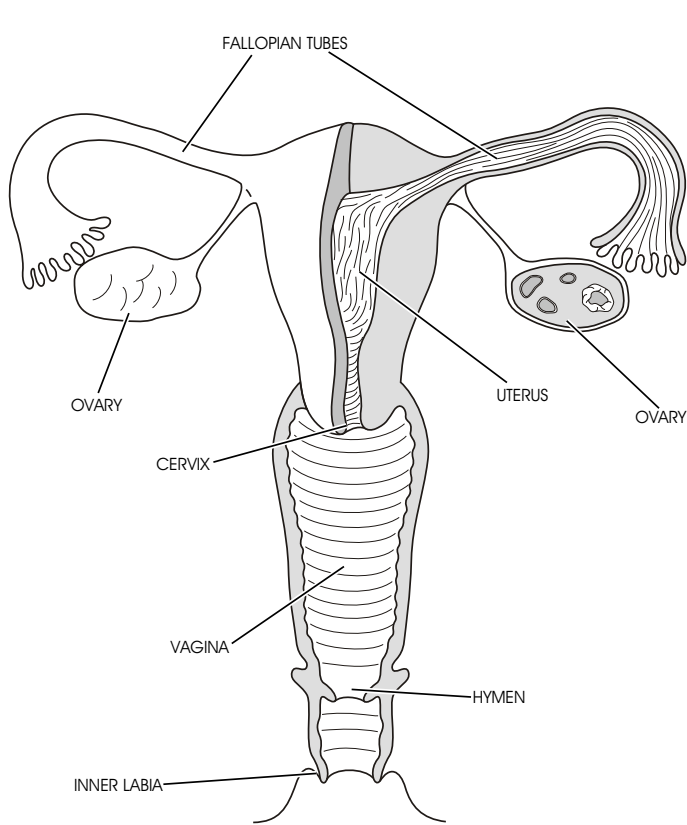

Front

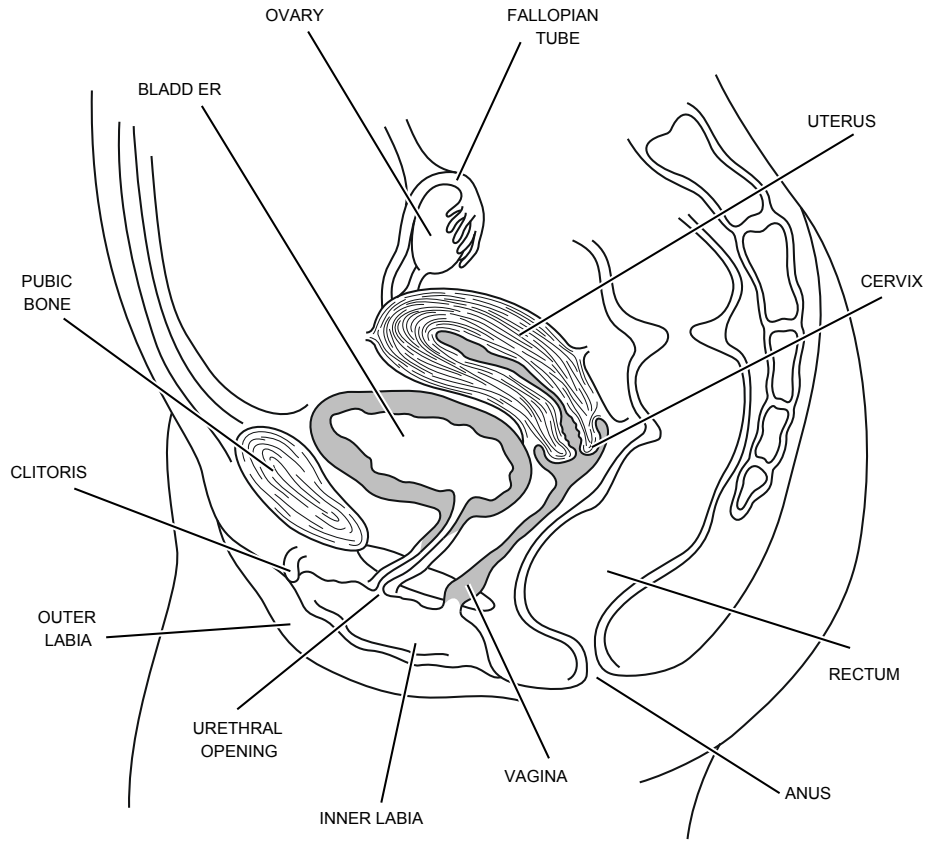

Side

Male Anatomy

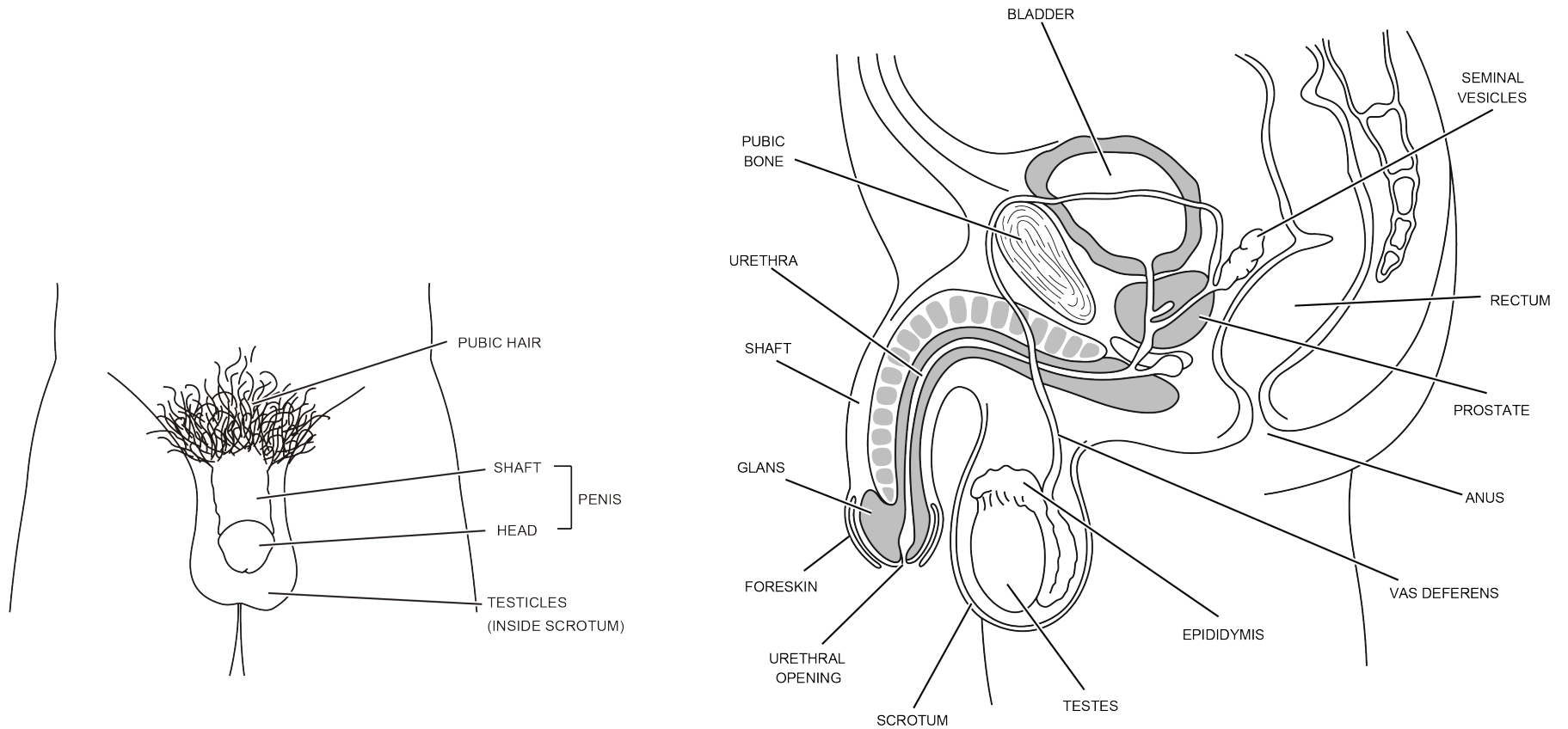

Front

Side



See Appendix C
for all other handouts
referenced in this activity.

Activity 3.4 What are the Seven Strategies for Effective Education?

Purpose

The purpose of this activity is to help staff identify the seven strategies for effective education and describe how to apply them at their site.

Who should participate?

Appropriate for any staff person who works in a family planning or reproductive health setting.

Especially important for staff who will be offering any contraceptive counseling or education.

Trainer Tip: To build participant confidence, be sure all participants have basic knowledge of each method of birth control, either by completing Activity 3.1 or through other training on birth control methods.

Time

30-45 minutes

Preparation

Review the following:

- Module 3 Preview & Preparation
- Activity 3.4 Handouts
- Providing Quality Family Planning Services (QFP), Appendix E — Strategies for Providing Information to Clients

Be prepared to identify 1-2 additional examples for each of the strategies. Identifying these additional strategies before the training may be useful in case participants request additional examples to help clarify the purpose of the strategies.

Materials

Handouts:

Make one copy for each participant:

- Seven Strategies for Effective Education

Supplies:

- Large paper to stick/tape to the wall, with one of the Seven Strategies for Effective Education written on each paper
 - Clear and easy to understand
 - Culturally and linguistically appropriate
 - Tailored information
 - Balanced information
 - Clear numbers and comparisons
 - Interactive and engaging
 - Teach-backs
- Markers, Pencils/pens, Masking tape

Resources

Have at least one printed copy available for reference:

- Providing Quality Family Planning Services (QFP): Recommendations of CDC and OPA, Appendix E
- Birth Control Methods Options chart
- Explaining Contraception Job Aids
- Any other relevant, method-specific information you use at your site

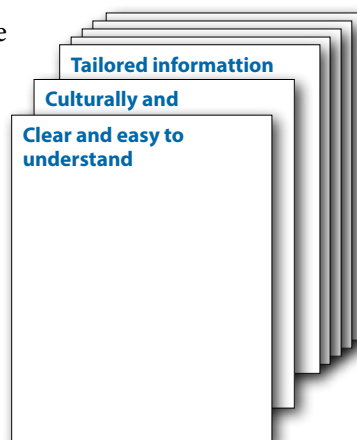

Detailed Instructions

1. Introduce the activity:

For clients to make informed decisions and follow treatment plans, they need clear and simple information. This activity will help us learn about and practice strategies that can help us provide this information. The Seven Strategies for Effective Education is adapted from the QFP, Appendix E. These strategies, developed from evidence-based educational toolkits and health literacy reviews, help us provide effective, client-centered contraceptive education. During the activity we will become more familiar with these strategies, create sample statements and identify examples that we can use in our clinic.

2. Distribute the Seven Strategies for Effective Education handout.

Trainer Tips: Modules 5 discusses the last strategy, teach-back, in much greater detail.

3. Divide participants into seven small groups or pairs.

Give each group a large paper with one of the seven strategies written at the top.

Fewer than 14 participants? Form as many pairs as you can, and give each pair two or more strategies to discuss.

At a Glance

Introduction

Purpose:

- Learn strategies for giving clients clear and simple info to support their decisions and plans

Strategies Handout



Small Groups/Pairs

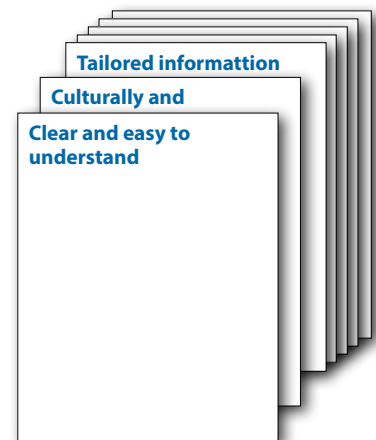

4. **Ask each group to write examples of their strategy.**

Ask groups to think about what their strategy might look like during a client visit. They should write their ideas on the paper for that strategy.

Tell participants:

- *Your examples could be about individual staff behavior, a patient handout, or clinic procedures.*
- *You can use the Seven Strategies for Effective Education handout for ideas.*
- *Select someone to be your group's "reporter" to share your list back with the full group and why your strategy is important for quality education.*

5. **Give groups about 5-6 minutes to create their lists.**

Fewer than 7 pairs? Allow more time for pairs working on 2+ strategies.

Ask each group to identify a reporter who will share their list back to the full group.

6. **Give each reporter ~3 minutes to present their group's list.**

With each strategy, ask if anyone from the larger group would like to add examples or if anyone has any questions or comments.

7. **After the reports, ask if anyone needs more clarification.**

If anyone needs more clarification on any strategies, explain as needed.

8. **Wrap up the activity**, sharing concluding comments such as:

- *Think about a new idea you got today that you'll use with clients. Would anyone like to share?*
- *Thank you for your participation in this activity! As we can see in the lists you created, there are many opportunities to use these seven strategies and incorporate them into our work.*
- *In the next activity, we'll practice all the strategies and skills we've learned in this Module.*

Trainer Tip: You could use ideas from the lists to create a job aid for staff to use during client visits.

Small Groups/Pairs

Clear and easy to understand

Appropriate literacy level in forms, brochures

Use plain language (vs. complicated medical terms or jargon)

Small Groups/Pairs

5-6 minutes

Share with Full Group

~3 minutes per group

Check Understanding

~3 minutes per group

**Wrap-Up
Activity 3.4 Complete**





See Appendix C
for all other handouts
referenced in this activity.



Activity 3.5 Applying the Seven Strategies to Contraceptive Education

Purpose

The purpose of this activity is to help staff practice using tools and strategies to explain the primary characteristics of available birth control methods in a simple, accurate, easy to understand manner.

Who should participate?

Appropriate for any staff person who works in a family planning or reproductive health setting.

Especially important for staff who will be offering any contraceptive counseling or education.

Trainer Tip: This activity assumes participants have current and accurate information about birth control method characteristics and an orientation to the Seven Strategies for Effective Education. If not, Activities 3.1, 3.2, and 3.4, or similar activities will be useful. This activity could also include “homework” for participants to review Explaining Contraception Job Aids and Seven Strategies.

Time

60 minutes

Preparation

Review the following:

- Module 3 Preview & Preparation
- Activity 3.5 Handouts

Prepare materials for the Role Play activity:

- Make copies of the scenario sheets:
 - **More than 6 participants?** Divide your group size by 3; make that many copies.
 - **Fewer than 6 participants?** Divide your group size by 2; make that many copies.
- Cut the scenario sheets so the Educator and Client sheets are separate.
- Make the same number of copies (one for each small group) of the following **Explaining Contraception Job Aids**:
 - **Intrauterine Device (IUD)** — for Scenario #1 Theresa
 - **Pills, The Shot (injection)** — for Scenario #2 Jordana
 - **Female Condom, Female Sterilization, Fertility Awareness-Based (FAB) Methods, Male Condom, Male Sterilization** — for Scenario #3 Maria
- Each group will practice educating each of these three clients, completing each scenario one time.

Materials

Handouts:

Make one copy for each participant (or reuse copies printed for prior activities):

- Birth Control Method Options chart*
- Seven Strategies for Effective Education
- Seven Strategies Observation Checklist

Make copies of the **Role Play Scenarios #1, #2 and #3 and Explaining Contraception Job Aids**; see instructions under Preparation to determine the number of needed copies.

Supplies:

- Multiple samples of each birth control method discussed in the scenarios
- Large paper to stick/tape to the wall or whiteboard (optional)
 - Pre-write debrief instructions and Key Concepts (optional)
- Markers (optional)

DEBRIEF

Clients: what was helpful?
(Focus on positives)

Educators: what felt good?
Challenging? What would you do differently?

Observers — what went well?
What strategies did you see?
What could be added?

KEY CONCEPTS

1. Education is an integral part of quality counseling
2. Using effective educ. strategies helps you give accurate, balanced, nonjudgmental info
3. Explain basic info of all methods in a tailored, accurate, easy to understand way

* You may use a different birth control method chart if the typical use effectiveness rates match those on the Birth Control Method Options chart.

Detailed Instructions

1. Introduce the activity:

Now that we've reviewed information about all of the contraceptive methods, and have discussed strategies for effective education, you will have the chance to fine tune your skills during a practice role play. Applying the effective education strategies will help you provide accurate but also easy to understand, balanced, tailored and culturally appropriate information for your client.

2. Give each participant a copy of each reference handout.

The handouts can serve as references during the practice.

At a Glance

Introduction

Purpose:

- Practice using effective education strategies to communicate information on contraceptive methods

Distribute Handouts

Explaining Contraception Job Aids (Female Condom, Female Sterilization, FAB Methods, IUD, Male Condom, Male Sterilization Pills, The Shot)

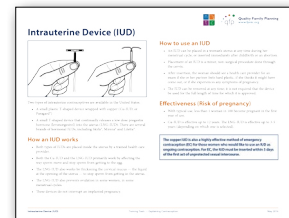

Birth Control Method Options

Seven Strategies for Effective Education

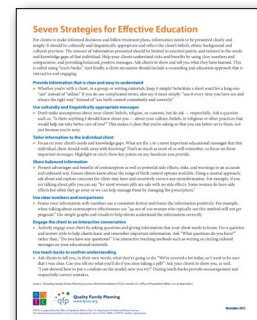

3. **Instruct participants to form groups of 3 and choose roles.**

Group members should decide who will begin as the ‘educator,’ ‘client,’ and ‘observer.’ All participants will have a chance to play all 3 roles one time, switching roles as the group switches scenarios.

Fewer than 6 participants? Have participants from pairs and eliminate the ‘observer’ role.

4. **Give each group samples of the methods discussed in the scenarios.**

Methods discussed in the scenarios include: IUD, pills, the shot/injection, female condoms, female sterilization, fertility awareness based (FAB) methods, male condom, and male sterilization.

5. **Hand out copies of and review the Observation Checklist.**

For those of you starting as the observers...use this checklist to track how the educator is incorporating the Seven Strategies and the Key Contraceptive Points into their counseling session.

This is not a test! This is an opportunity to receive supportive and helpful feedback.

6. **Distribute Educator and Client sheets for Role Play #1 to each group.**

For the clients — Note that you will share the other information on your sheet as the practice visit progresses and your ‘educator’ asks questions and shares information.

You may notice that all the role plays feature female clients. This is because we are focusing on methods primarily for women. You may change your role to be a male client if desired; just be sure to let your ‘educator’ know.

Groups of 3

Group members choose roles:

- Educator
- Client
- Observer

Method Samples

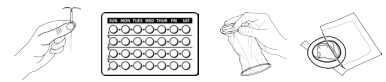

Observation Checklist

**Seven Strategies
Observation Checklist**

Seven Strategies Observation Checklist

Please listen for the following Strategies as you observe. Put a check mark after each skill you observe and some brief notes to document how it was used.

Clear and easy to understand ____

Culturally and linguistically appropriate ____

Tailored information ____

Balanced information ____

Clear numbers and comparisons ____

Interactive and engaging ____

Confirming understanding ____

**Role Play 1 —
Educator & Client Sheets**

Role Play #1 — Educator’s description

Client: Theresa, a 16 year old female with no children

Reason for visit: She is here for her first clinic visit and would like to start on a method of birth control. She has decided to use an IUD.

Focus of the role play: Explain methods of birth control in a simple, accurate, easy to understand manner. The goal for this activity is not to help the client choose a method, but simply to give them information about the methods they have expressed interest in.

Be sure to cover the following points (not necessarily in order):

- Ask about what Theresa already knows about IUDs, and what questions she has.
- Talk about the safety of IUDs, the different types of IUDs available, and the benefits of IUDs.
- Address side effects, including possible changes in bleeding patterns.
- Share information on how long the IUD protection will last, and options for removal.
- Address STD protection.

Reference the following Contraceptive Fact Sheets as needed: Intrauterine Device (IUD)

Role Play #1 — Client’s description

Theresa

You are 16 years old, with no children.

This is your first visit to the clinic and you’d like to start on a method of birth control. You’ve decided you’d like to use the IUD.

Other information that you eventually share with the educator: You have decided on the IUD because you wanted a very effective method you wouldn’t have to think about, but your older sister told you that IUDs are not all the same to use. It’s really old. You also have questions about the bleeding spotting that can be a side effect of using an IUD. You’re not sure about the difference between the copper one vs. the one with hormones.

7. **Instruct participants to begin the role play session.**

- **Clients** — start by sharing your name, age, gender and reason for visit with your 'educator'
- **Educators** — you may refer to the handouts as a reference and use the Birth Control Method Options chart and sample birth control methods as educational tools with your 'client'
- **Observers** — use the Seven Strategies Observation Checklist to track the session

You'll have about 10 minutes for this first role play.

8. **After 10 minutes, tell each group to debrief quickly within their group.**

Give the groups 2-3 minutes to discuss the following topics, just with those in their small group:

(Optional: Post on large paper, whiteboard, or PowerPoint slide.)

- **Clients** — talk about what was helpful for you during the role play; stay focused on the positives and strengths you saw.
- **Educators** — after you hear from the 'client,' describe to the others in your group what your experience was like during the role play. What felt good? What was more challenging? What would you want to do differently?
- **Observers** — after you've heard from the 'educator' and 'client,' share your observations. What did the educator do well? What strategies were used? Were there strategies not used or key contraceptive points that were not discussed?

9. **Have participants switch roles within their group for Role Play 2.**

Participants should move on to a new Role Play as they switch roles, versus repeating the same Role Play in different roles. This will allow you to move through all three Role Plays in a timely manner.

Role Play 1

10 minutes

Debrief 1

2-3 minutes

DEBRIEF

Clients: what was helpful?
(Focus on positives)

Educators: what felt good?
Challenging? What would you do differently?

Observers — what went well? What strategies did you see? What could be added?

Switch Roles, Role Plays

- Participants change to a new role (client, educator or observer) within their group
- Prepare for Role Play 2



10. Distribute Educator and Client sheets for Role Play #2 to each group.

Role Play 2 — Educator & Client Sheets

Role Play #2 — Educator's description

Client: Jordana, a 25 year old female with no children.

Reason for visit: She has decided to switch from the pill to the shot.

Focus of the role play: Explain methods of birth control in a simple, accurate, easy to understand manner. The goal for this activity is not to help the client choose a method, but simply to give them information about the methods they have expressed interest in.

Be sure to cover the following points (not necessarily in order):

- Ask about what Jordana already knows about the shot, and what questions she has.
- Address side effects, including possible changes in bleeding patterns.
- Talk about expected return to fertility after someone stops getting the shot.
- Discuss effectiveness of the shot, in comparison to pills.
- Address STD protection.

Reference the following Contraceptive Fact Sheets in needed: Pills, The Shot (injection)

Role Play #2 — Client's description

Jordana:
You are 25 years old, with no children.
You've come to the clinic today because you'd like to switch from the pill to the shot.

Other information that you eventually share with the educator: You were having trouble remembering to take a pill every day and thinking it might be easier to remember to get your shot every 13 weeks. You're not in a serious relationship right now, so no plans for children in the near future, but have questions about how quickly you will return to being fertile after stopping the shot. You are wanting to know what differences there are in taking the pill vs getting the shot.

11. After 10 minutes, tell each group to debrief quickly.

Debrief 2

2-3 minutes

DEBRIEF

Clients: what was helpful?
(Focus on positives)

Educators: what felt good?
Challenging? What would you do differently?

Observers — what went well? What strategies did you see? What could be added?

12. Have participants switch roles within their group for Role Play 3, so each group member is playing the role they haven't played yet.

Switch Roles, Role Plays

13. Distribute Educator and Client sheets for Role Play #3 to each group.

Role Play 3 — Educator & Client Sheets

Role Play #3 — Educator's description

Client: Maria, a 35 year old female with three children age 10 and older

Reason for visit: Maria has been taking pills off and on for 15 years and wants to give her body a "break from hormones". She does not plan on having more children.

Focus of the role play: Explain methods of birth control in a simple, accurate, easy to understand manner. The goal for this activity is not to help the client choose a method, but simply to give them information about the methods they have expressed interest in.

Be sure to cover the following points (not necessarily in order):

- Ask about what Maria already knows about the non-hormonal methods, and what questions she has.
- Share basic information about available non-hormonal methods, including natural family planning.
- Include discussion of male condoms and female condoms.
- Discuss vasectomy as one possible option for Maria.

Reference the following Contraceptive Fact Sheets as needed: Female Condom, Male Condom, Female Sterilization, Male Sterilization, Fertility Awareness Based (FAB) Methods

Role Play #3 — Client's description

Maria

You are 35 years old with three children, all over the age of 10.

You've come to the clinic today because you've been taking pills off and on for 15 years and want to give your body a "break from hormones".

Other information that you eventually share with the educator: You feel strongly about using a non-hormonal method. You and your current partner do not plan to have children together. You've talked with your partner about vasectomy as an option, but you're also interested in learning more about natural methods of birth control that you've heard people talk about.

14. After 10 minutes, tell each group to debrief quickly.

Debrief 3

2-3 minutes

DEBRIEF

Clients: what was helpful?
(Focus on positives)

Educators: what felt good?
Challenging? What would you do differently?

Observers — what went well? What strategies did you see? What could be added?



15. Bring everyone back to the larger group for a discussion.

- Any general comments about how the Role Playing process went? Any a-ha moments?
- As a client, was there anything specific your 'educator' did that was very helpful for you?
- Who can share how the process went for you... as an educator? Any surprises?
- As an observer, what did you notice that was effective?
- Who would like to share something they plan to integrate into their education approach?

16. (Optional, if time) Lead a more detailed debrief about the three role play scenarios:

- What questions do you have about **Theresa** and the discussion about the different IUDs?
- What were challenges in **Jordana's** situation in comparing the pill vs. changing to the shot?
- What kinds of information did you share given **Maria's** stated interest in non-hormonal methods?

17. Review the Module 3 Key Concepts for Participants.

There are three Key Concepts I want to highlight for this entire series of activities on accurate birth control information and effective education:

- Education is an integral component of the quality contraceptive counseling process.
- Using effective education strategies helps you deliver accurate, balanced, nonjudgmental information to clients.
- It's important to be able to explain the basic information of all contraceptive methods in a tailored, accurate, and easy to understand way.

Trainer Tip: If you plan to go through Modules 4 and 5 with the same group of participants, note that these same education skills will come up in each of those modules.

Full Group Discussion

- General comments / a-has?
- As a client, what was helpful?
- How was the process as an educator?
- What did observers notice?
- What do you plan to integrate into your work?

Optional Scenario Discussion

- Theresa / IUDs?
- Jordana / pill vs. shot?
- Maria / non-hormonal methods?

Key Concepts

KEY CONCEPTS

1. Education is an integral part of quality counseling
2. Using effective educ. strategies helps you give accurate, balanced, nonjudgmental info
3. Explain basic info of all methods in a tailored, accurate, easy to understand way



18. **Wrap up the activity:**

*In summary, effective education is not just about providing accurate information but also **how** you communicate it.*

Thank you all for taking a personal risk today to practice these skills and strategies in front of your colleagues. Practicing with your colleagues is a great opportunity to ask for feedback and suggestions. Remember that providing quality, client-centered contraceptive counseling takes lots of practice!

**Wrap-Up
Activity 3.5 Complete**





Seven Strategies Observation Checklist

Please listen for the following Strategies as you observe. Put a check mark after each skill you observe and some brief notes to document how it was used.

Clear and easy to understand _____

Culturally and linguistically appropriate _____

Tailored information _____

Balanced information _____

Clear numbers and comparisons _____

Interactive and engaging _____

Confirming understanding _____



Role Play #1 — Educator's description

Client: Theresa, a 16 year old female with no children

Reason for visit: She is here for her first clinic visit and would like to start on a method of birth control. She has decided to use an IUD.

Focus of the role play: Explain methods of birth control in a simple, accurate, easy to understand manner. The goal for this activity is not to help the client **choose** a method, but simply to give them information about the methods they have expressed interest in.

Be sure to cover the following points (not necessarily in order):

- Ask about what Theresa already knows about IUDs, and what questions she has.
- Talk about the safety of IUDs, the different types of IUDs available, and other considerations for each type of IUD.
- Address side effects, including possible changes in bleeding patterns.
- Share information on how long the IUD protection will last, and options for removal.
- Address STD protection.

Reference the following Explaining Contraception Job Aids as needed: Intrauterine Device (IUD)

Role Play #1 — Client's description

Theresa

You are 16 years old, with no children.

This is your first visit to the clinic and you'd like to start on a method of birth control. You've decided you'd like to use the IUD.

Other information that you eventually share with the educator: You have decided on the IUD because you wanted a very effective method you wouldn't have to think about, but your older sister told you that IUDs are not ok for teens to use. Is it really ok? You also have questions about the bleeding/spotting that can be a side effect of using an IUD. You're not sure about the difference between the copper one vs. the one with hormones.



Role Play #2 — Educator’s description

Client: Jordana, a 25 year old female with no children

Reason for visit: She has decided to switch from the pill to the shot.

Focus of the role play: Explain methods of birth control in a simple, accurate, easy to understand manner. The goal for this activity is not to help the client **choose** a method, but simply to give them information about the methods they have expressed interest in.

Be sure to cover the following points (not necessarily in order):

- Ask about what Jordana already knows about the shot, and what questions she has.
- Address side effects, including possible changes in bleeding patterns.
- Talk about expected return to fertility after someone stops getting the shot.
- Discuss effectiveness of the shot, in comparison to pills.
- Address STD protection.

Reference the following Explaining Contraception Job Aids as needed: Pills, The Shot (injection)

Role Play #2 — Client’s description

Jordana

You are 25 years old, with no children.

You’ve come to the clinic today because you’d like to switch from the pill to the shot.

Other information that you eventually share with the educator: You were having trouble remembering to take a pill every day and thinking it might be easier to remember to get your shot every 13 weeks. You’re not in a serious relationship right now, so no plans for children in the near future, but have questions about how quickly you will return to being fertile after stopping the shot. You are wanting to know what differences there are in taking the pill vs. getting the shot.



Role Play #3 — Educator’s description

Client: Maria, a 35 year old female with three children age 10 and older

Reason for visit: Maria has been taking pills off and on for 15 years and wants to give her body a “break from hormones.” She does not plan on having more children.

Focus of the role play: Explain methods of birth control in a simple, accurate, easy to understand manner. The goal for this activity is not to help the client **choose** a method, but simply to give them information about the methods they have expressed interest in.

Be sure to cover the following points (not necessarily in order):

- Ask about what Maria already knows about the non-hormonal methods, and what questions she has.
- Share basic information about available non-hormonal methods, including natural family planning.
- Include discussion of male condoms and female condoms.
- Discuss sterilization as one possible option for Maria.

Reference the following Explaining Contraception Job Aids as needed: Female Condom, Male Condom, Female Sterilization, Male Sterilization, Fertility Awareness-Based (FAB) Methods

Role Play #3 — Client’s description

Maria

You are 35 years old with three children, all over the age of 10.

You’ve come to the clinic today because you’ve been taking pills off and on for 15 years and want to give your body a “break from hormones.”

Other information that you eventually share with the educator: You feel strongly about using a non-hormonal method. You and your current partner do not plan to have children together. You’ve talked with your partner about sterilization as an option, but you’re also interested in learning more about natural methods of birth control that you’ve heard people talk about.



See Appendix C
for all other handouts
referenced in this activity.

Module 4: Interactive Client-Centered Decision Making

Module Preview and Preparation

Key Concepts for Participants

1. Our role as professionals is to offer our expertise to support a client-centered decision making process, focused on the goals and preferences of each client.
2. Conducting an assessment to explore the many factors that may influence a client's preference for and satisfaction with a method will help the client make an informed birth control decision.
3. When we use an interactive client-centered decision making process, our clients are much more likely to be satisfied with their chosen method and use it consistently and correctly.

About This Module

This module focuses on the interactive nature of a client-centered decision making process by integrating concepts from the first four **QFP Quality Counseling Principles**. The training activities in this module will help participants explore the complexities of contraceptive decision making and the various influences and priorities that individuals have when considering family planning method choices.

This module addresses the following **Quality Counseling Principles** included in the *middle* section of the **Contraceptive Counseling Process Guide**:

Principle: Assess the client's needs and personalize discussions accordingly

Principle: Work with the client interactively to establish a birth control method plan

Middle		
<p>Assess the client's needs and personalize discussions accordingly</p> <ul style="list-style-type: none"> ▶ Review and update the medical, sexual and social history ▶ Explore client preferences regarding method characteristics: frequency of use, effectiveness, how to use, menstrual changes, side effects, and benefits ▶ Ask about client knowledge and experience with birth control methods ▶ Address pregnancy and parenting intention/ambivalence along with STD/HIV protection ▶ Respectfully explore client beliefs and feelings, including ethnic, cultural, and/or individual factors that may be relevant to their birth control method decisions and method use 	<p>Work with the client interactively to establish a birth control method plan</p> <ul style="list-style-type: none"> ▶ Ask open-ended questions about concerns or possible barriers relevant to method choice ▶ Explore the client's method preferences, and if appropriate, offer additional information about the most effective methods ▶ Help the client to optimize method choice by assisting the client in aligning their preferences with their method selection ▶ Reflect back important thoughts or feelings you hear from the client and/or feelings you sense from the discussion ▶ Clarify partner involvement and the role of others who may be important to the client's decision making and method use ▶ Affirm and support the decision making process with a respectful, nonjudgmental approach in helping the client make a plan 	<p>Provide information that can be understood and retained by the client</p> <ul style="list-style-type: none"> ▶ Provide balanced, unbiased, tailored information about method characteristics in an interactive conversation ▶ Provide accurate information (correct use, effectiveness, benefits, side effects, potential risks, STD/HIV protection) ▶ Use clear, understandable words, images, materials, models and/or sample methods ▶ Use numbers and comparisons that are easy to understand ▶ Assess and address myths and misinformation in a respectful and affirming way ▶ Include information about STD protection and emergency contraception

These principles highlight key elements of an interactive, client-centered assessment and decision making process. This process is supported by the principles and skills discussed in earlier modules related to rapport-building, communication, and effective education.

Why This Module Matters

When clients make an informed birth control decision — meaning, they have a clear understanding of all of their options for birth control, have explored how these options relate to their preferences, and have chosen freely — they are much more likely to be satisfied with their method and use it consistently and correctly.



Important Terms

As you prepare to deliver this module, familiarize yourself with the following terms:

Client-centered decision making involves:

- Exploring the client’s preferences for method characteristics, including assessing knowledge and preferences around method effectiveness.
- Using client-centered interpersonal skills, including building rapport through such techniques as asking open ended questions, providing affirmations, and reflecting the client’s experiences. (Module 2);
- Providing tailored education that can be understood and retained by the client (Module 3);
- Providing support for clients in identifying which methods are the best match for their preferences; and
- Respecting how the client wishes to make decisions about their birth control method.

Influences that a client may consider related to choosing a contraceptive method may include the client’s pregnancy intentions or reproductive life plan, past contraceptive experiences, preferences around method type and use, desired effectiveness, concerns about side effects, and STD risk factors, as well as the attitudes of a partner or parent, among other factors.

Reproductive life planning includes discussing one’s life goals as they relate to childbearing. It helps both women and men think about if and when they would like to have children.

Trainer Tip: See the special “Trainer Notes” section of this module for additional background as you prepare to discuss the important topic of client-centered decision making with staff.



Training Activities in this Module

Activity 4.1 A “Perfect” Birth Control Method? (30 minutes)

Purpose: Participants will be able to recognize factors that influence client preferences around birth control during various life stages, and will be aware of their own personal preferences in order to prevent bias.

In this activity, you will:

- Invite participants to brainstorm criteria a person would look for in a “perfect” method.
- Review the results of the “criteria” brainstorm, exploring the various considerations and influences that are a part of a client’s contraceptive decision making process.

Activity 4.2 Factors that Influence Contraceptive Decision Making (30 minutes)

Purpose: Participants will be able to identify assessment questions to elicit information about a client’s personal values, beliefs, priorities, influences and preferences related to sexual and reproductive health and contraceptive decision making.

In this activity, you will:

- Lead participants in a brainstorm of factors that influence contraceptive decision making.
- Discuss assessment approaches participants could use to explore these factors with a client, briefly reviewing the “Middle” of the **Contraceptive Counseling Process Guide**.

Activity 4.3 Personalized and Interactive Client Assessment (30-45 minutes)

Purpose: Participants will be able to intentionally tailor the interactive assessment process and educational messages based on a client’s values, goals and preferences.

In this activity, you will:

- Guide participants through a case study of an interactive assessment process.
- Solicit suggestions throughout the case study of possible assessment questions.

Activity 4.4 Client-Centered Decision Making (60-90 minutes)

Purpose: Participants will be able to engage clients in an interactive, client-centered decision making process through which a client determines her or his preferred birth control method.

In this activity, you will:

- Instruct participants to form groups to work through role play situations, rotating through the roles of a “counselor,” “client” and “observer.”
- Distribute role play scenarios, observer checklists, handouts, and tools to facilitate the practice.



General Guidance for All Activities:

- Suggested language for the trainer to say out loud is in italics and shaded. We encourage you to cover these points in your own words and add additional comments relevant to your site.

Example:

This activity is to help us step back and think about what “client-centered” really means and how it’s demonstrated when a person is making a very personal and important life decision.

- We encourage you to be creative with how you present the content within the activities. Have fun, and make it your own! While the content is evidence-based and should be delivered with fidelity, there are many training approaches you could use to help your participants engage with this content. See *Effective Teaching Methods* for ideas, or incorporate your own favorite training strategies!



Trainer Notes

Module 4 focuses on the interactive nature of a client-centered decision making process by integrating concepts from the first four **QFP Quality Counseling Principles**. Due to the importance of this topic, both for trainers preparing to teach these skills and staff preparing to implement them, we've included a special section for this module that offers additional background information and key considerations.

Foundational Assessment

A client-centered decision making process begins with an assessment of the client's needs in order to personalize discussions accordingly. The assessment may include:

1. **Reviewing and updating the medical, sexual and social history** to clarify potential health issues, cultural and personal life considerations, psychological concerns, and a client's values and preferences.
2. **Exploring pregnancy and parenting intention along with STD protection.**
3. **Asking about client knowledge and experience with birth control methods.**
4. **Respectfully exploring client beliefs and feelings, including ethnic, cultural, and/or individual factors that may be relevant to their birth control method decisions and method use.**
5. Asking, if relevant, about a partner's involvement in the selected method of choice.
6. **Assessing myths and addressing misinformation in an assuring way.**
7. Based on the assessment, **tailoring information to the client's needs and knowledge gaps** to ensure client understanding.

While the above items offer a foundational framework for assessment, there may be a need to consider other decision making factors in a client's life:

- **Personal life circumstances** may influence decision making such as homelessness and income, substance and/or alcohol use, or other life or social situations.
- **Reproductive/contraceptive coercion** may play a role in decision making. A partner or another person may have a major influence on a client's access to and/or consistent and correct use of a birth control method. Sexual coercion and sexual violence may also play a role, if a client is being coerced or forced into sexual contact against their will.
- Asking about the **opinions of other people in the client's life (e.g., partner, parent)** or any other influence(s) on family planning decisions should be considered and explored, as indicated.

An interactive client-centered decision making process involves assessing and being guided by the client's preferences, while also making sure the client has complete and accurate information about all available methods including the method effectiveness, potential side effects and how clients might manage them, and other considerations in method choice that relate to each client's life and lifestyle.

Decision Making and the Impact of Ambivalence

Decision making related to sexual activity and/or the use of contraception can be very complex and filled with conflicting feelings that result in ambivalence, or thoughts or statements such as "I'm just not sure" or "I have no idea what I want to do." A client may experience ambivalence when struggling with factors related to birth control decision making but not yet specifically related to a method choice. These decisions may be related to their personal values, relationships, and other life circumstances.



Example: A young woman is beginning to think about her advancing age and wondering if she is ready to plan a pregnancy even if she has no steady partner. This might be a time to explore reproductive life planning and pregnancy goals before deciding on a birth control method.

Example: A teen client is still not certain about becoming sexually active. Some days he may want to have sex; other days he remembers his parent has strongly advised against having sex at an early age.

Use your assessment to clarify these three questions related to contraceptive decision making:

1. *Is your client clear about being sexually active now?*
(yes; no; not sure; maybe not with this partner; etc.)
2. *Is your client comfortable deciding to use birth control?*
(yes; no; not sure; yes, but it's against my parent's choice/my partner's choice/my culture/etc.)

If “yes” to using birth control:

3. *What's important to your client in a birth control method?*

Provider Influence on Client Decision Making:

What if the client's decision about birth control is different from what you (as the counselor) think is the “best” method for your client (or couple)? At times, we want very much to make sure a client has a very effective method, such as an IUD or an implant. But the final choice must be the client's choice — one that is made freely and with complete and accurate information.

A common example of this challenge is when a question is asked: *What is the best method for a teen?*

- Some professionals who provide contraceptive counseling will answer — *An IUD is best for a teen because it's one of the most effective methods.*

- But another professional may be relying on outdated information and say — *Teens should not have an IUD because IUDs are too much of a health risk.*

In fact, neither of these hypothetical professionals would be right. The evidence shows that an IUD is safe for nearly all women, including teens. However, it is also wrong to assume that a given method is best for a client based just on observable client characteristics (like age) and method effectiveness. We must always share accurate, balanced, and complete information about all birth control options.

What is the best method of birth control? The one the client chooses. Evidence continues to show that clients are more likely to be satisfied and to continue to practice family planning when they have adequate information about contraceptive options, have their concerns heard and addressed, and make a decision about their method without pressure or coercion.

We must also remind clients that it is okay for them to change their minds about birth control. Their choice about a method may be different in different circumstances, with different partners, at different stages of the life course, or if their chosen method simply doesn't meet their needs as well as they thought it would.

To facilitate these very important (and sometimes complex) decision making conversations with clients it is important to remember our commitment to a client-centered, culturally aware approach to prevent unintentional bias in an attempt to “help” your client.

Our professional goal for contraceptive counseling and education is to engage in a shared (client — provider) decision making process. The focus is on the client's preferences, needs and goals, while the provider ensures that the client has accurate information, is considering birth control options that are safe and effective, and has access to additional referrals and resources as needed.



Activity 4.1 A “Perfect” Birth Control Method?

Purpose

The purpose of this activity is to help staff recognize the many factors that influence birth control method preference, and appreciate that clients prioritize these factors in different ways.

Who should participate?

Appropriate for any staff person who works in a family planning or reproductive health setting.

Especially important for staff who will be offering any contraceptive counseling or education.

Time

30 minutes

Preparation

- Review Module 4 Preview & Preparation

Materials

Supplies:

- Large paper to stick/tape to the wall
- Markers

Detailed Instructions

1. Introduce the activity:

During this activity you will imagine that you are inventing the perfect method of birth control.

You'll brainstorm key factors or criteria a person would look for in the perfect method, and then explore how different people prioritize decision making influences in their own unique way..

2. Break participants into groups of 2-4 people.

Give each group a piece of large paper and markers.

Fewer than 5 participants?

Do the activity together as a large group.

3. Give participants the following instructions:

- Pretend you are inventing the perfect method of birth control.
- Imagine that you need to tell the developers the criteria, or factors, that will make it perfect.
- Write these perfect criteria or factors on your paper.
- Feel free to use different colored markers and draw pictures!
- After you're done, stick or tape your paper to the wall for the rest of us to see.

4. Give participants time to walk around and look at all the papers.

5. Bring everyone back to the large group for a discussion.

- What was this process like, generating criteria with your group? Did you agree on everything?
- As you look at all the groups' lists — any comments or observations?
- What do you think about these criteria?
- In your perspective, are there any existing methods of birth control that are perfect, or close to perfect? What makes them perfect — or “close to perfect?” Would any be perfect for everyone? Would they be perfect for the same person throughout their reproductive life time?
- Are there any other methods that are associated with any of the factors you identified on your lists? (examples: the IUD and implants are highly effective and last a long time; Paragard and barrier methods don't use hormones; condoms protect against STDs, etc.)

At a Glance

Introduction

Purpose:

- Brainstorm the key factors and priorities for people trying to find the perfect method

Small Groups

- Groups of 2-4
- Large paper and markers

Small Groups: Invent Perfect Method

The Perfect Method

Easy to use

Effective

~~Side effects~~

Walk & Observe

Full Group Discussion

- What was the process like?
- Any comments or observations?
- Thoughts on the criteria?
- Are any existing methods perfect? For everyone/all the time?
- Are there other methods associated with any factors you identified?

6. **Help the group reflect on and share how this exercise is related to a client’s contraception decisions.**

- *If you asked your clients what they thought about a “perfect birth control method,” what do you think they would say?*

Trainer Tip: The key idea here is that **it would depend on the individual client**. Make sure this idea is expressed, especially if participants are all similar in their idea of the “perfect” or “best” method.

- *How do we help clients determine what is most important **to them** when choosing a method?*
- *How do we keep our own, personal views or preferences in check, when supporting a client to decide what is best for her or him, while also providing accurate information?*

7. **Wrap up the activity**, summarizing with comments such as:

Clients must be given the opportunity to explore what is important and meaningful to them when deciding on a birth control method. While there is no “perfect” or “best” method for everyone, quality counseling and education can help you engage clients in a conversation that ultimately reveals a method the client chooses freely, with accurate information and resources to use it correctly and consistently, at this point in his or her life.

For individual clients, the “perfect” method for this person may change during their reproductive lifetime. Creating a sense of trust and respect helps clients feel welcome, and able to return for a different method if the one they select doesn’t work out or doesn’t meet their expectations.

Group Reflection

- What do you think your clients would say about a perfect method?
- How do we help clients determine what is best for them?
- How do we keep our own views in check?

**Wrap-Up
Activity 4.1 Complete**





Activity 4.2 Factors that Influence Contraceptive Decision Making

Purpose

The purpose of this activity is to identify and discuss the multiple factors that influence sexual and reproductive health decisions. We will focus on contraceptive decision making, and brainstorm assessment questions that will elicit information about personal values, beliefs, priorities, influences and preferences.

Who should participate?

Appropriate for any staff person who works in a family planning or reproductive health setting.

Especially important for staff who will be offering any contraceptive counseling or education.

Time

30 minutes

Preparation

Review the following:

- Module 4 Preview & Preparation
- Activity 4.2 PowerPoint Presentation
- Activity 4.2 Handouts

Materials

Handouts:

Make one copy for each participant:

- Contraceptive Counseling Process Guide
- How Do I Choose?

Presentation:

Load onto laptop and/or print slides as a handout for participants:

- Factors that Influence Contraceptive Decision-Making

Supplies:

- *(if available for presentation)* Laptop, projector and screen
- Large paper to stick/tape to the wall or whiteboard
- Markers

Detailed Instructions

1. Introduce the activity:

The purpose of these Module 4 activities is to focus on the interactive nature of a client-centered decision-making process that integrates:

- *Exploring how a client values different method characteristics based on that client's individual preferences, priorities, and personal circumstances;*
- *Helping a client identify a method that best fits their preferences;*
- *Working together with the client to establish a plan to use their chosen method; and*
- *Providing information in a way that can be easily understood and retained by the client.*

This process, included in the "The Middle" section of the Contraceptive Counseling Process Guide, reminds us to first assess the client's personal goals and help them identify the important factors in their decision making process.

2. Review the Key Concepts for Participants.

(Optional: Post on large paper or white board.)

There are three Key Concepts for our activities on interactive client-centered decision making:

- *Our role as professionals is to offer our expertise to support a client-centered decision making process, focused on the goals and preferences of each client.*
- *Manually conducting an assessment to explore the many factors that may influence a client's preference for and satisfaction with a method will help the client make an informed birth control decision.*
- *When we use an interactive client-centered decision making process, our clients are much more likely to be satisfied with their chosen method and use it consistently and correctly.*

At a Glance

Introduction

Purpose:

- Focus on the interactive nature of a client-centered decision-making process including:
- Exploring how a client values different method characteristics
 - Helping a client align preferences with a method
 - Working together to establish a plan for use
 - Providing easy to understand information

Key Concepts

1. Professional role = offer expertise to support client-centered decision making
2. Assessment to explore factors influencing client preferences/satisfaction → informed decision
3. Client-centered process → more satisfied clients, consistent/correct method use

3. **Conduct the PowerPoint Presentation** (or use the slides handout).

The purpose of this activity is to identify and discuss the multiple factors that influence sexual and reproductive health decisions, and more specifically, contraceptive decision-making.

Although some clients may come to the clinic with a clear sense of what they need and a clear goal for the current visit, it is still important to conduct an assessment to make sure that they are confident that the method they are choosing is really what's going to work best for them.

When clients make an informed decision, that is, they have a clear understanding of their options for birth control and have explored how these options relate to their preferences, they are much more likely to be happy with their method and use it every time they have sex and always the right way.

So what should be included in our assessment?

What do we want to ask about?

How do we learn about these other factors?

(Optional: Write responses on large paper or whiteboard.)

Title Slide

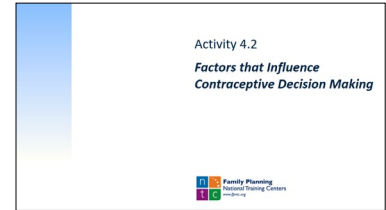

Purpose

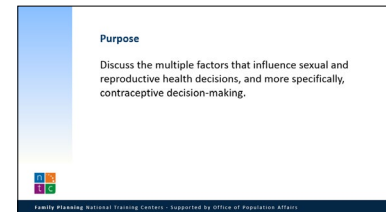

Why is this so important?

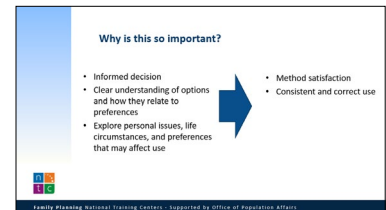

What should be included?

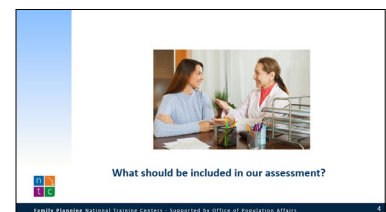

These factors will likely have been raised during the brainstorm on the previous slide.

When thinking of all of the different areas of assessment you could explore with a client, it's helpful to think about where you might start. Here are three key questions to consider at the start of an assessment conversation:

Click the mouse for each bullet to appear.

- Does the client have any **health issues and/or safety considerations** that would rule out using any methods?
- What is the client's **reproductive life plan or pregnancy and parenting intentions**, both now and in the future?
- **What's important** to your client in a method? This will be different for every client. Some clients don't want hormones and others just want the most effective method, some need their method to be private, etc. This key question helps you start to identify how your client values different method characteristics.

Trainer Tip: Characteristics of birth control methods are reviewed in detail in Module 3, Activities 3.1 and 3.2.

Many of these factors will likely have been raised during the brainstorm on the earlier slide.

Often when counseling we move too quickly to the birth control method decision without exploring a person's sexual activity decisions and other personal considerations.

Click the mouse for each bullet to appear.

- Religious or **cultural considerations** may play a role.
- Clients may have a range of **values and preferences**, that may differ from your own. Remember, personal values are deeply held and must be respected.
- It's also helpful to talk about **partner involvement**. For example, if a female client with a male partner wants to use male condoms, has the partner agreed to use them all the time, and is he able to use them correctly?
- **Personal life circumstances** may influence decision-making, such as homelessness and income, mental health issues, substance and/or alcohol use, or other life or social situations.
- **Reproductive/contraceptive coercion or intimate partner violence** may have a major impact on decision-making. A partner or another person may influence a client's access to and/or consistent and correct use of a birth control method.

Initial Assessment Considerations

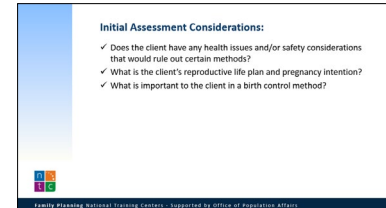

Factors that influence contraceptive decision making

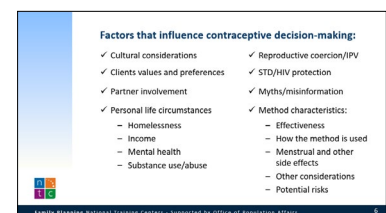

- It's important to discuss your client's needs in terms of protection from **STDs and HIV**.
- Assess whether your client has **concerns based on myths or misinformation** that should be clarified.
- Different clients will value or prioritize different **characteristics of birth control methods**. Some may be looking for the most **effective** method, while for others, how the method is used, and how often, will be a major factor in their decision making. For others, **side effects** may be most important.

Looking at this list and the one you all generated, where do you already ask about these factors? Do we cover all of this on our forms or EHR?

Discuss which currently used assessment forms or EHR screens at your site would bring up these issues.

The "Middle" section of the Contraceptive Counseling Process Guide also provides a list of assessment factors to explore.

Contraceptive Counseling Process Guide

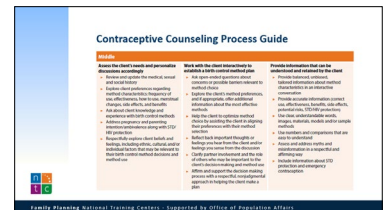

Now let's think about HOW you get at this information. What specific questions might you ask?

Some of this information will be readily available from the client's history form, like the "other health issues." Try to brainstorm questions to address the list on the previous slide.

Consider when it would be useful to ask open-ended questions and when to ask a closed-ended question.

When do you summarize what your client has been saying?

Write ideas on large paper or whiteboard.

Question Brainstorm

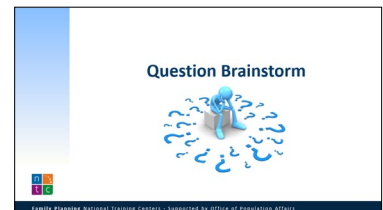

(Distribute copies of the “How Do I Choose?” handout.)

You can use this “How Do I Choose?” job aid to help you think of questions to ask both female and male clients.

What do you think of these questions? Any that stand out?

How do you think you could use this tool?

Which type of staff in our clinic are most likely to be responsible for asking which questions?

Remember to keep your personal values and biases out of the counseling session. There may be things that surface that push your buttons or that you have strong feelings about, but the purpose of exploring these other factors or influences is to help your client determine what method will work best for her.

What if the client’s decision about birth control is different from what you (as the counselor) think is the “best” method for your client (or couple)?

At times, we want very much to make sure a client has a very effective method, such as an IUD or an implant.

But the final choice must be the client’s choice — one that is made freely and with accurate information.

For example, in response to the question, “What is the best method for a teen?” two providers might respond in two very different ways, depending on their own knowledge, interpretation, and values.

(Ask two volunteers to read the italicized statements aloud.)

We know the second statement is inaccurate; IUDs are safe for nearly all women, including teens.

However, the first statement is also false. It assumes the best method for a client based on only one thing – their age.

The best method for a teen — and for any client — is the one the client chooses.

How Do I Choose?



Your Personal Values



What is the best method for a teen

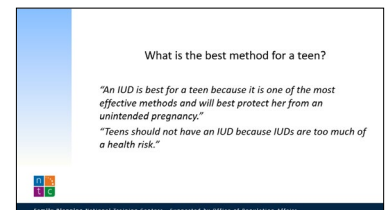

What is the best method for a teen

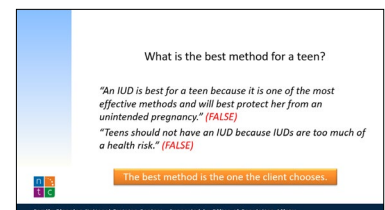

Any other questions or comments about influencing factors?

References & Resources and Contact Information are included at the end of each presentation.

4. **Wrap up the activity.** In your own words, review these key messages:

- Ask questions — Clients may not always be aware of the many factors that could affect their use of and satisfaction with a method until they're asked the questions we discussed.
- Our clients must make the choice. When clients make an informed decision, fully understand the method and have explored all the possible issues (such as potential side effects) that could affect use, they are much more likely to use their method consistently, correctly and be happy with their choice.
- Share your knowledge; not your values. Provide clients with accurate information and options, but stay clear of letting your personal values and opinions influence your clients' decisions.
- Thank you for helping identify and create the foundation for interactive client-centered decision-making.

Trainer Tip: Activities 4.3 and 4.4 will give participants an opportunity to explore these influences further and practice applying what you've learned with case studies and role plays.

Questions / Comments



References & Resources and Contact Information

Wrap-Up Activity 4.2 Complete





See Appendix C
for all other handouts
referenced in this activity.



Activity 4.3 Personalized and Interactive Client Assessment

Purpose

The purpose of this activity is to help staff practice how to intentionally tailor the interactive assessment process and educational messages related to contraceptive decision making based on the clients' values, goals and preferences.

Trainer Tip: This activity is most effective when followed immediately by **Activity 4.4, Client Centered Decision Making**. Activity 4.3 focuses on tailoring an assessment to the individual client, and Activity 4.4 integrates assessment into an interactive client centered decision making process.

Who should participate?

Appropriate for any staff person who works in a family planning or reproductive health setting.

Especially important for staff who will be offering any contraceptive counseling or education.

Trainer Tip: This activity uses the skills from **Activity 2.2, The OARS Model — Essential Communication Skills**. Participants should have completed Activity 2.2 or be otherwise familiar with the OARS skills.

Time

30–45 minutes

Preparation

Review the following:

- Module 4 Preview & Preparation
- Activity 4.3 Handouts
- Activity 4.3 PowerPoint

Materials

Handouts:

Make one copy for each participant (or use copies printed for previous activities):

- How Do I Choose?
- OARS Model: Essential Communication Skills
- Conducting a Sexual Health Assessment (optional)

Presentation:

Load onto laptop and/or print slides (2 slide per page) as a handout* for participants:

- Personalized and Interactive Client Assessment

Supplies:

- (if available for presentation) Laptop, projector and screen
- Large paper to stick/tape to the wall or whiteboard
- Markers (optional)

Resources

Have at least one printed copy available for reference:

- Principles for Providing Quality Counseling
- Contraceptive Counseling Process Guide

*If you are printing the presentation slides as a handout, consider how you might print and distribute the slides so that participants can process them one at a time. The goal of the activity is to simulate how counselors learn more about their client with each assessment question they ask, so it's important that participants don't "read ahead" and learn all the details about the client right away.

Detailed Instructions

1. Introduce the activity:

We're going to take time now to explore the interactive process of personalizing a conversation for each individual client. This activity will take a step-by-step approach to help us practice tailoring our interaction with a client at every step of the visit. We'll practice how to ask questions, carefully listen to the response, and then build on that response to ask additional tailored questions. This interactive process ensures that the counseling and education conversation is guided by your client's needs.

After we've spent this focused time on having an interactive assessment conversation with the client, we'll have a chance in **Activity 4.4, Client Centered Decision Making**, to apply all of our skills in practicing an integrated, client-centered assessment and decision making process.

2. Distribute copies of the handouts:

How Do I Choose? handout:

The questions in the **How Do I Choose?** handout highlight some of the many factors that can influence a client's choice in using birth control or deciding which method to use. As we move through the activity, these questions may give you ideas for how to explore a client's needs, goals and preferences, and then tailor the questions you ask and the information you share accordingly.

OARS Model — Essential Communication Skills handout:

We'll use the **OARS** communication skills throughout this exercise, so you have an **OARS Model** handout outlining those skills as well.

Conducting a Sexual Health Assessment handout (optional):

The **5 Ps** handout suggests some additional questions you may ask to assess your client's need for protection against STDs and HIV. It's important to help clients make a plan to protect themselves from STDs/HIV, whichever birth control method they choose.

At a Glance

Introduction

Purpose:

- Learn how to personalize a conversation for each client
- Practice how to ask questions, listen, and build on responses with tailored follow-up questions

Handouts

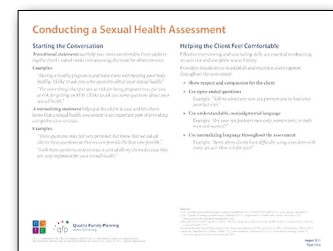
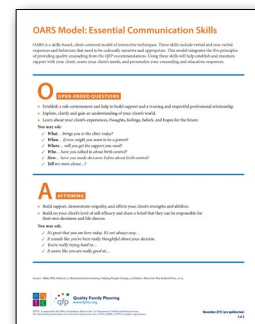
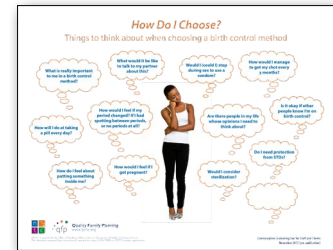



3. Explain the process for the step-by-step assessment activity.

Trainer Tips: If you printed the presentation slides as handout, rather than doing an electronic presentation, you will pass out copies of the individual slides as the activity progresses.

In this step-by-step activity, I'll share a series of prompts with you where we learn more and more about our client, Mia. With each new prompt, you'll have the opportunity to think of what additional questions you might ask or messages you might share.

With each prompt, I'll first give you a couple of minutes to talk with 1 or 2 people sitting around you, about what questions or responses you might have for Mia. Then we'll come back together in the full group to share some of what we came up with, and then see the next prompt.

Fewer than 6 participants? You can move through the activity steps as a full group.

*You will all come up with many different answers in terms of what you could say to Mia. **The important thing is to use good communication skills and a client-centered approach to keep learning more about your client, and giving her tailored information that meets her needs.***

4. Start the PowerPoint Presentation for the step-by-step activity.

Remember — this activity is focused on the interactive and personalized assessment process when working with a client. This brief interaction will not include some of the other important components of a counseling encounter such as reviewing confidentiality or doing a more complete review of a client's medical and social history.

For this activity we are going to specifically explore the contraceptive related preferences of our client — Mia.

This first prompt — in the next slide — will be around learning more about Mia by asking open-ended questions and thinking about what she might tell you. Our goal is to learn about Mia so that we can offer tailored information and options based on her unique needs, goals, and priorities.

Explain Activity Process

Meet Mia

Activity 4.3
Personalized
and Interactive
Client
Assessment

Meet Mia

Mia is an 18 year old, single woman who will attend college in the fall and has come to the clinic for contraception.

What open-ended questions would you ask to learn about unique needs, goals and priorities?

Family Planning National Training Centers | Supported by Office of Population Affairs

The volunteer participant reads the text on this slide about what we already know about Mia from her medical and social history and that she is undecided about a birth control method. After they finish reading, click to have the questions at the bottom of the slide appear.

Give instructions for small group conversation:

Take some time to talk to 1 or 2 people around you:

- *What open-ended questions would you ask?*
- *What would be the most important thing to say to Mia?*

After 2-3 minutes, bring the full group back together:

What were some of your ideas about starting the conversation with Mia?

Raise the following points if not mentioned by participants:

- **Ask about condom use** — *you could say, “What can you tell me about using condoms in the past and how you felt about using condoms?”*
- *It’s important to use **open-ended questions**, not ask “Did you use condoms all the time?” You want to give a client a chance to talk about how condom use worked for them.*
- *You also want to offer **affirmations** for Mia for planning ahead and coming to the clinic (to help establish rapport and trust right at the beginning of the visit).*

Make a transition to the next slide, where you’ll learn more about Mia.

Meet Mia

Activity 4.3
Personalized
and Interactive
Client
Assessment

Meet Mia

Reviewing Mia’s medical and social history we know:

- She has been sexually active in the past.
- She has used condoms for pregnancy and STD/HIV prevention.
- She has no apparent medical conditions that would prevent her from using any of the methods.

She is undecided about what method she wants today.

What open-ended questions would you ask her to find out more information in order to talk about birth control options?

What would be important to say to Mia?

Family Planning National Training Centers | Supported by Office of Population Affairs

Ask for a volunteer to read the text on the slide about Mia. After they finish reading, click to have the questions appear.

Talk to 1 or 2 people around you:

- *What open-ended questions would you ask?*
- *How can you reflect what you hear Mia saying?*

After 2-3 minutes, bring the full group back together:

What were your ideas about continuing the conversation with Mia?

You can refer to the How Do I Choose? handout for some of the suggested questions. Be sure to raise the following points if not mentioned by participants:

- Ask about **Mia's priorities** — you could say, "What is the most important thing to you about birth control?"
- **Reflect Mia's need for privacy** — you could say, "It sounds like having a method that is private is important." You could also remind her about our confidentiality policy.
- Reflecting is an important skill to help us **gain a deeper understanding** of each client.
- It's important to be **nonjudgmental** about Mia's inconsistent condom use.

Make a transition to the next slide, where you'll learn more about Mia.

Questions and Reflections

Activity 4.3
Personalized
and Interactive
Client
Assessment

Questions and Reflections for Mia

Mia mentions that she stopped using condoms, because she didn't like to stop during sex to have her partner put on a condom.

She adds that she will live at home this first year of college and her parents will "freak out" if they knew she was having sex.

What open-ended questions would you ask her to find out more information about her life and what's important to her?

How can you reflect what you hear Mia saying?

Family Planning National Training Centers | Supported by Office of Population Affairs

Ask for a volunteer to read the text on the slide about Mia. After they finish reading, click to have the questions appear.

Talk to 1 or 2 people around you:

- *What kinds of affirmation can you offer Mia?*
- *How can you reflect what you hear Mia saying about her goals and preferences?*
- *What open-ended questions would you ask?*

After 2-3 minutes, bring the full group back together:

What affirmations, reflections and questions did you think of for Mia?

Raise the following points if not mentioned by participants:

- *Affirm Mia's choice to come to the clinic — you could say, "I think you are being very responsible by coming in today and getting on a birth control method."*
- *Reflect back that it sounds like pregnancy isn't in the near future because Mia talked about college in the fall.*
- *Ask questions to clarify Mia's reproductive life plan, such as "What are your thoughts or feelings about having kids at some point later in your life?"*

Make a transition to the next slide, where you'll talk about summarizing what you've heard and transitioning to other assessment topics.

Affirmations and Reflections

Activity 4.3
Personalized
and Interactive
Client
Assessment

Affirmations and Reflections for Mia

After you've been talking for awhile, Mia shares that she had a pregnancy scare last year. Now that she is starting college, pregnancy prevention is the most important thing.

What kinds of affirmations can you continue to offer Mia?

How can you reflect what you hear Mia saying about her goals and preferences?

What open-ended questions would you ask to further explore Mia's preferences and priorities related to birth control?

Family Planning National Training Centers, supported by Office of Population Affairs

Ask for a volunteer to read the text on the slide about Mia. After they finish reading, click to have the questions appear.

Talk to 1 or 2 people around you:

- *What affirmations can you continue to offer Mia?*
- *How would you summarize what you've heard from Mia so far in this conversation?*
- *How can you transition your conversation toward asking about partners and protection from STDs and HIV as well as pregnancy?*

After 2-3 minutes, bring the full group back together:

What affirmations did you think of? What about summarizing and transitioning the conversation to new topics?

Raise the following points if not mentioned by participants:

- *Affirm that it sounds like Mia is pretty clear about the birth control characteristics that are important to her.*
- *Ask open-ended questions about partners, such as "What can you tell me about any sexual partners you may have?" Don't make any assumptions about the number or gender of partners.*
- *Transition into new topics — for example, you could say, "These questions may feel very personal, but know that we ask all clients these questions so we can provide the best care possible."*

Make a transition to the next slide — it is the last slide where you'll ask people to brainstorm in small groups.

Summarizing and Transitions

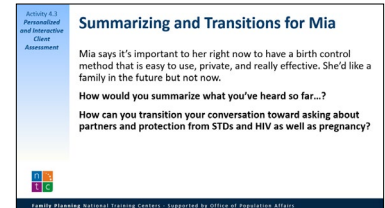

Activity 4.3 Personalized and Interactive Client Assessment

Summarizing and Transitions for Mia

Mia says it's important to her right now to have a birth control method that is easy to use, private, and really effective. She'd like a family in the future but not now.

How would you summarize what you've heard so far...?

How can you transition your conversation toward asking about partners and protection from STDs and HIV as well as pregnancy?

Family Planning National Training Centers. Supported by Office of Population Affairs.

Ask for a volunteer to read the text on the slide about Mia. After they finish reading, click to have the questions appear.

Trainer Tip: Distribute **Conducting a Sexual Health Assessment** handout if using.

Talk to 1 or 2 people around you:

- What questions would you ask Mia? Be sure to include assessment questions before jumping into educational messages.
- What educational discussion would you have with Mia?

After 2-3 minutes, bring the full group back together:

What questions would you ask Mia to guide your education? What educational topics might you cover in your discussion?

Raise the following points if not mentioned by participants:

- Ask about Mia's history of STDs/HIV — e.g., "Have you ever been tested for HIV/STDs, and if so, when and what were the results?"
- Engage Mia in a self-assessment of her risk for STDs/HIV – you can ask, "How have you protected yourself in the past?"
- Before jumping into educational messages, be sure to ask, "What do you know about STDs and HIV?"
- Include other key points from *Conducting a Sexual Health Assessment*.

Make a transition to the next slide, where you'll summarize as a full group.

Questions and Education

Activity 4.3
Personalized
and Interactive
Client
Assessment

Mia mentions that she doesn't have one steady partner. She does have sex, occasionally, with a few different ex-boyfriends.

What questions would you ask Mia?
What educational discussion would you have with Mia?

Family Planning National Training Centers | Supported by Office of Population Affairs

Lead a discussion with the full group.

What have you learned about Mia?

- *What are her needs and goals?*
- *What are some of the priorities in her life right now?*
- *What influences are present in her life?*
- *What is really important to her in thinking about preventing pregnancy and other health risks?*

After discussing what participants have learned about Mia, ask:

What else do you need to know to help her find the best “match” of a birth control method, at this point in her life?

Lastly, discuss the following (emphasizing that you’re not “picking” a method for Mia, but identifying methods that may align with her stated preferences, priorities, and personal life circumstances):

What method(s) might you discuss based on what you know now?

Transition your discussion into a large group debrief of the full activity.

5. Lead a full group debrief of the activity

During the case scenario, what did you notice about what you wanted to ask and the information that you provided?

Invite participants to share responses.

This activity is a clear example of personalizing and gathering information to better meet the client’s needs. Each client has unique needs and life circumstances, and the best method is the one that the client chooses.

We don’t “offer” methods... we explore with the client the methods that might work for them.

What have you learned about Mia?

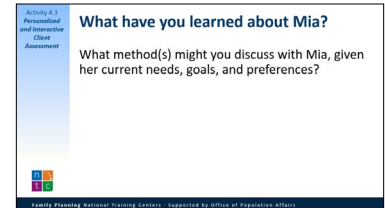

Group Debrief

- What did you notice about what you wanted to ask and the info you provided?
- We don’t “offer” methods... we explore with the client the methods that might work for them.

6. **Wrap up the activity**, highlighting the following in your own words:

- *Thank you for your participation in this activity.*
- *In order to offer quality education and counseling to our clients, the birth control options we talk about, or the educational messages we provide, must be tailored to fit our clients' needs, beliefs, values, and priorities.*
- *This may seem overwhelming, as each client is unique.*
- *But, by asking questions about the client's life circumstances and what they find important for a method, you will gather information to provide tailored information and discuss birth control options that will be the best fit for your client.*

**Wrap-Up
Activity 4.3 Complete**





See Appendix C
for all other handouts
referenced in this activity.



Activity 4.4 Client-Centered Decision Making

Purpose

The purpose of this activity is to help staff practice how to engage clients in an interactive, client-centered decision making process through which a client determines her or his preferred birth control method.

Who should participate?

Appropriate for any staff person who works in a family planning or reproductive health setting.

Especially important for staff who will be offering any contraceptive counseling or education.

Trainer Tip: Participants should have completed the previous activities in Modules 1-4 or be otherwise familiar with the content and skills outlined in the **Contraceptive Counseling Process Guide**.

Time

60–90 minutes

Preparation

Review the following:

- Module 4 Preview & Preparation
- Activity 4.4 Handouts

Prepare materials for the Role Play activity:

- Make copies of the scenario sheet:
 - **More than 6 participants?** Divide your group size by 3; make that many copies.
 - **Fewer than 6 participants?** Divide your group size by 2; make that many copies.
- Cut the scenario sheets so that the Counselor and Client roles for each scenario are separate. Put the sheets for each scenario in a different envelope to keep them organized.

Materials

Handouts:

Make one copy for each participant (or use copies printed for previous activities):

- Interactive Contraceptive Counseling and Education
- Client Centered Decision Making Observation Checklist
- Birth Control Method Options chart*
- How Do I Choose?

Supplies:

Make copies of the **Role Play Scenarios #1, #2 and #3** — see instructions under Preparation to determine the number of needed copies.

- Samples of birth control methods
- Large paper to stick/tape to the wall or whiteboard with written small group debrief instructions (optional)
- Scratch paper and pens

Resources

Have at least one printed copy available for reference:

- Explaining Contraception Job Aids
- Principles for Providing Quality Counseling
- Contraceptive Counseling Process Guide

DEBRIEF

Clients: what was helpful?
(Focus on positives)

Counselors: what felt good?
Challenging? What would you do differently?

Observers: what went well?
What skills were used? What from the checklist could be added?

* You may use a different birth control method chart if the typical use effectiveness rates match those on the Birth Control Method Options chart.

Detailed Instructions

1. Introduce the activity:

This activity will give you a chance to practice, in a role play situation, how to assess client need and personalize discussions accordingly. When you play the role of the counselor, you will be able to practice how to work interactively with a client to help the person determine a preferred method of birth control.

2. Give each participant a copy of each handout for reference.

- Interactive Contraceptive Counseling and Education
- Client Centered Decision Making Observation Checklist
- Birth Control Method Options chart
- How Do I Choose? handout

Let participants know that they can also use the Explaining Contraception Job Aids and method samples during the activity.

At a Glance

Introduction

Purpose:

- Practice assessing client need and personalizing discussions
- Practice helping client choose a preferred method

Handouts

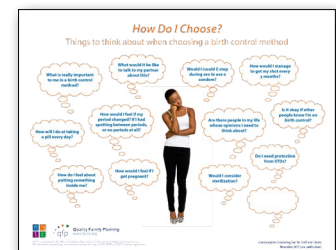
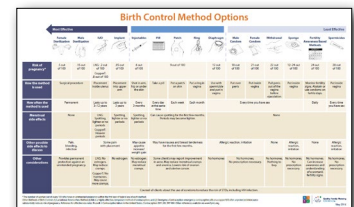
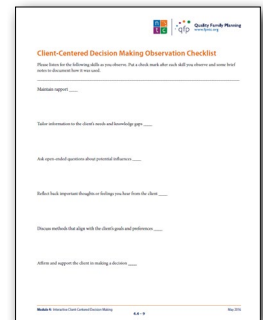
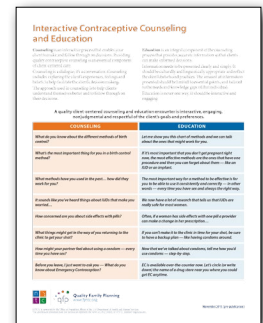

3. Instruct participants to form groups of 3 and choose roles

Within their groups of 3, participants should decide who will begin as the ‘counselor,’ ‘client,’ and ‘observer.’ All participants will have a chance to play each role.

Fewer than 6 participants? Have participants from pairs and eliminate the ‘observer’ role.

4. Review the Observation Checklist.

For those of you starting as the **observers**... use this checklist to track how the counselor is incorporating key skills (in an interactive way) into their facilitation of client-centered decision making. **This is not a test!** This is an opportunity to receive helpful and supportive feedback.

5. Distribute Counselor and Client sheets for Role Play 1 to each group.

Carefully read the information you’ve been provided. You’ll notice that the Counselor and the Client have received different information.

- **Clients** — you will share the information on your sheet as the practice visit progresses and your ‘counselor’ asks questions and shares information. You should follow your role as described, but you can add to it creatively.
- **Counselors** — you may refer to the handouts as a reference and use the Birth Control Method Options chart and sample birth control methods as educational tools with your ‘client.’

Groups of 3

Group members choose roles:

- Counselor
- Client
- Observer

Observation Checklist

The form is titled 'Client-Centered Decision Making Observation Checklist' and includes several sections for tracking observations: 'Name of observer', 'Date and time of observation', 'Date and time of role play', 'Did you observe the counselor using the following skills?', and 'Did you observe the counselor using the following skills?'. It also has a section for 'Comments' and a signature line for the observer.

Remember, this is an opportunity to receive helpful and supportive feedback!

Role Play 1 — Counselor & Client Sheets

Note: Counselor and Client have different information

This sheet is titled 'Role Play #1 - Counselor's description'. It provides background information on the client, Olivia, and lists the goals for the role play. It includes a list of skills to observe and a section for the counselor to use as a reference during the role play.

This sheet is titled 'Role Play #1 - Client's description'. It provides background information on the client, Olivia, and lists the goals for the role play. It includes a list of skills to observe and a section for the client to use as a reference during the role play.

6. **Instruct participants to begin the role play session.**

Let participants know that they'll have about 10 minutes for this first role play.

7. **After 10 minutes, tell groups to debrief within their small group.**

Give the groups 5 minutes to discuss the following topics, just with those in their small group:

(Optional: Post on large paper, whiteboard, or PowerPoint slide.)

- **Clients** — After you've heard from the 'counselor,' talk about what was helpful for you during the role play; stay focused on the positives and the strengths you saw.
- **Counselors** — Describe to others in your group what your experience was like during the role play. What felt good? What was more challenging? What would you want to do differently?
- **Observers** — After you've heard from the 'counselor' and 'client,' share your observations. What did the counselor do well? What key skills were used? Was there anything on the checklist that you did not observe?

8. **Have participants switch roles within their group for Role Play 2.**

Participants should move on to a new Role Play as they switch roles, versus repeating the same Role Play in different roles. This will allow you to move through all three Role Plays in a timely manner.

9. **Distribute Counselor and Client sheets for Role Play 2 to each group.**

Role Play 1

10 minutes

Small Group Debrief 1

5 minutes

DEBRIEF

Clients: what was helpful? (Focus on positives)

Counselors: what felt good? Challenging? What would you do differently?

Observers: what went well? What skills were used? What from the checklist could be added?

Switch Roles, Role Plays

- Participants change to new role (client, counselor or observer) within their group
- Prepare for Role Play 2

Role Play 2 — Counselor & Client Sheets

Role Play #2 — Counselor's description

Client: Single, 24-year-old female, a single mom with 2 children (daughter age 9 and son age 11).
Reason for the visit: Pregnancy test.

Context: On this role play, assume that you are parting through the visit with this client. You have already:
1) Established rapport.
2) Explored confidentiality and readiness for opening.
3) Established an agenda about the client's reasons for visit.
4) Reviewed client's medical, mental, and social history which revealed one clinical contraindication for any contraceptive methods.

Focus of the role play: Your goal is to learn about your client and help identify a method that they are confident will work well for her as an individual.

Things to learn about your client:

- Client and preferences
- Knowledge and experiences
- Family and friends
- Other influences and life circumstances
- Importance of patient education
- HIV prevention

Using what you learn, help them identify a method that they are confident will work and use it effectively.

Role Play #2 — Client's description

Allegit

You are 24, a single mom with 2 children (daughter age 9 and son age 11).
You are coming to the clinic today for a pregnancy test. You're worried that it is negative. You may want another child and the clinic has not met your need and will refer you elsewhere.
You are a husband comes to see your about children, sometimes, and occasionally for stay overnight. You and your ex-husband sometimes have sex. They are healthy with no chronic health issues.
You have used pills, the Depo shot, spermicide, and condoms for birth control over the years.
You do not like using birth control at all.
You like having regular periods and get nervous when your period was a couple of weeks late.

10. After 10 minutes, tell each group to debrief quickly.

11. Have participants switch roles within their group for Role Play 3, so each group member is playing the role they haven't played yet.

12. Distribute Counselor and Client sheets for Role Play 3 to each group.

13. After 10 minutes, tell each group to debrief quickly.

Small Group Debrief 2

5 minutes

DEBRIEF

Clients: what was helpful?
(Focus on positives)

Counselors: what felt good?
Challenging? What would you do differently?

Observers: what went well?
What skills were used? What from the checklist could be added?

Switch Roles, Role Plays

Role Play 3 — Counselor & Client Sheets

Role Play #3 — Counselor's description

Client: You're a 20-year-old single male.

Reason for the visit: STD check.

Concern: You're nervous about the concern that you are partner through the visit with this client. You have already:

- 1) Healthful diet options
- 2) Emotional availability and emotional support
- 3) Collaborated to make about the client concern or goal
- 4) Reviewed client's medical, social and sexual history

Focus of the role play: Your goal is to learn about your client and help identify a method that they are confident will work with their own situation.

Things to learn about your client:

- Goals and preferences
- Knowledge and experiences
- History of STDs
- Other influences and life circumstances
- Level of interest in your service/visit
- STD prevention

Using what you know, help them identify a method that they are confident will work with their own situation.

Role Play #3 — Client's description

Role: You are a 20-year-old male client who comes to the clinic for STD screening but also wants to learn more about birth control.

You have a girlfriend but you do also have sex with other women, sometimes.

In terms of what you know about birth control and sexual health, you're looking for information on the Internet, but have some questions about how to help your girlfriend decide on a method.

You sometimes have sex with men, although you're not likely to share this information with your provider unless asked.

Small Group Debrief 3

DEBRIEF

Clients: what was helpful?
(Focus on positives)

Counselors: what felt good?
Challenging? What would you do differently?

Observers: what went well?
What skills were used? What from the checklist could be added?



14. **Bring everyone back to the larger group for a discussion.**

- *Reflecting on the role plays, how did it go? What stands out?*
- *For those playing the role of the client, what helped you feel more comfortable and trusting of the counselor?*
- *What did the counselors do well to engage the client in an interactive decision making process?*
- *What are some examples of effective open-ended questions that were asked?*
- *How did counselors keep the conversation “client-centered”?*
- *How did the counselors bring up the client’s personal experiences? How did the counselors elicit medical, sexual and social history? What questions did they ask?*
- *Were there any challenges? Lessons learned?*

15. **(Optional, if time) Lead a more detailed debrief about the three role play scenarios:**

Scenario #1 — Olivia

- *Was Olivia ambivalent (unsure) about her birth control choice?*
- *What comments or questions do you have about your role in facilitating a client’s decision making process when the client is not sure (or clear) about a birth control choice?*

Scenario #2 — Abigail

- *Were there other issues to explore in Abigail’s situation?*
- *Did you explore other sexual partners – Abigail’s and/or her ex-husband’s?*

Scenario #3 — Jayden

- *How did you prioritize Jayden’s questions about his girlfriend and birth control and other factors in his sexual activity?*
- *How did you explore Jayden’s sexual activity with other partners related to gender, STD/HIV prevention, etc.?*

Full Group Discussion

- General reflections?
- As a client, what was helpful?
- What did counselors do to engage the client interactively?
- What open-ended questions were asked?
- How did counselors bring up client’s personal experiences?
- Challenges? Lessons learned?

Optional Scenario Discussion

- Olivia / ambivalence?
- Abigail / other issues?
- Jayden / sexual activity and partners?

16. Wrap up the activity:

Ask participants to quietly reflect for a moment, and think about what they observed and learned during the role plays.

Distribute scratch paper and pens and ask participants to take < 5 minutes to quickly write down (for a personal reminder) what they plan to do differently when counseling clients on birth control options in a client-centered way.

After participants are done writing, in your own words, share concluding comments such as:

Thank you for your participation in practicing these important skills to help us provide the best possible care to our clients. Practicing these skills is a continuing process. We learn more about our skill and expertise as we work with different clients who have different experiences and needs.

When clients have explored possible issues and life circumstances that may influence their effective use of a method, have a clear and accurate understanding of the method, feel respected, and have had the opportunity to actively participate in decision making regarding a desired method—they are more likely to be satisfied with the method, and use it correctly and consistently.

Wrap-Up Activity 4.4 Complete





Client-Centered Decision Making Observation Checklist

Please listen for the following skills as you observe. Put a check mark after each skill you observe and some brief notes to document how it was used.

Maintain rapport _____

Tailor information to the client's needs and knowledge gaps _____

Ask open-ended questions about potential influences _____

Reflect back important thoughts or feelings you hear from the client _____

Discuss methods that align with the client's goals and preferences _____

Affirm and support the client in making a decision _____

Role Play #1 — Counselor’s description

Client: Olivia, 25 year old female who is single, living with her partner James and has no children

Reason for the visit: Well woman visit

Context: For this role play, assume that you are partway through the visit with this client. You have already:

- 1) Established rapport
- 2) Explained confidentiality and mandated reporting
- 3) Confirmed or asked about the client’s reason for visit
- 4) Reviewed client’s medical, social and sexual history, which revealed **no clinical contraindications for any contraceptive methods**

Focus of the role play: Your goal is to learn about your client and help identify a method that they are satisfied with and will be able to use effectively.

Things to learn about your client:

- Goals and preferences
- Knowledge and experiences
- Feelings and beliefs
- Other influences and life circumstances
- Involvement of partner and/or others
- STD protection

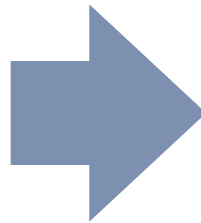

Using what you learn, help them identify a method that they are satisfied with and can use effectively

Role Play #1 — Client’s description

Olivia

You’ve come to the clinic today for your well woman visit and to renew your pill prescription.

You are 25 years old and have been living with your partner James for the past year. You do not plan on marriage or children in the near future. You are both very clear that having a pregnancy at this time in both of your lives would *“not be convenient.”*

You have been using pills for the past 3 years and you like them, but you do miss a pill *“now and then.”*

You like taking the pill. It’s easy, your periods are light, and you *“mostly remember to take them.”*

You’re open to hearing what a counselor says about an implant or IUD, but you won’t bring them up yourself, and you don’t want either one. You don’t want an implant or IUD put into your body.

Role Play #2 — Counselor’s description

Client: Abigail, 34 year old female, a single mom with 2 children (daughter age 9 and son age 5)

Reason for the visit: Pregnancy test

Context: For this role play, assume that you are partway through the visit with this client. You have already:

- 1) Established rapport
- 2) Explained confidentiality and mandated reporting
- 3) Confirmed or asked about the client’s reason for visit
- 4) Reviewed client’s medical, social and sexual history, which revealed **no clinical contraindications for any contraceptive methods**

Focus of the role play: Your goal is to learn about your client and help identify a method that they are satisfied with and will be able to use effectively.

Things to learn about your client:

- Goals and preferences
- Knowledge and experiences
- Feelings and beliefs
- Other influences and life circumstances
- Involvement of partner and/or others
- STD protection

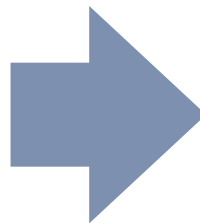

Using what you learn, help them identify a method that they are satisfied with and can use effectively

Role Play #2 — Client’s description

Abigail

You are 34, a single mom with 2 children (daughter age 9 and son age 5).

You’ve come to the clinic today for a pregnancy test. You re relieved that it is negative. You may want another child in the future but not now and not with your ex-husband.

Your ex-husband comes to see your shared children, sometimes, and occasionally he stays overnight. You and your ex-husband “*sometimes have sex.*” You are healthy with no chronic health issues.

You have used pills, the Depo shot, spermicides, and condoms for birth control over the years.

You do not like using birth control at all.

You like having regular periods and got worried when your period was a couple of weeks late.

Role Play #3 — Counselor’s description

Client: Jayden, 26 year old single male

Reason for the visit: STD check

Context: For this role play, assume that you are partway through the visit with this client. You have already:

- 1) Established rapport
- 2) Explained confidentiality and mandated reporting
- 3) Confirmed or asked about the client’s reason for visit
- 4) Reviewed client’s medical, social and sexual history

Focus of the role play: Your goal is to learn about your client and help identify a method that they are satisfied with and will be able to use effectively.

Things to learn about your client:

- Goals and preferences
- Knowledge and experiences
- Feelings and beliefs
- Other influences and life circumstances
- Involvement of partner and/or others
- STD protection

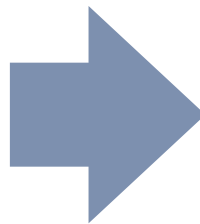

Using what you learn, help them identify a method that they are satisfied with and can use effectively

Role Play #3 — Client’s description

Jayden

You are a 26 year old male client who comes to the clinic for STD screening but also wants to learn more about birth control.

You have a girlfriend but you do also have sex with other women, sometimes.

In terms of what you know about birth control and sexual health, you’ve looked for information on the Internet, but have some questions about how to help your girlfriend decide on a method.

You sometimes have sex with men, although you’re not likely to share this information with your provider unless asked.



See Appendix C
for all other handouts
referenced in this activity.

Module 5: Confirming Understanding and Making a Plan

Module Preview and Preparation

Key Concepts for Participants

1. Closing the session is a key time to explore and address any additional information needed about the chosen method and potential barriers to use of this method.
2. Confirming a client's understanding and providing accurate information will help enable the client to use the chosen contraception method correctly and consistently.
3. Staff should confirm the client's plan for follow-up, including a back-up plan and/or emergency contraception, appropriate to the method chosen.
4. To support method satisfaction and decrease risk of discontinuation, staff should encourage all clients to return to the clinic at any time with questions or concerns or if they want to change their method.

About This Module

The purpose of this module is to focus on the client visit after a contraceptive choice (confirmed by a clinician's method eligibility determination, if indicated) has been made by the client.

This module addresses the following **Quality Counseling Principle** included in the *closing* section of the **Contraceptive Counseling Process Guide**:

Principle: Confirm client understanding

Closing

Confirm client understanding

- ▶ Ask the client to tell and show what was learned (teach-back) and provide additional information, as needed
- ▶ Address any possible barriers to a successful plan and method use
- ▶ Confirm the client's plan for correct method use and follow-up, including what to do if dissatisfied with the method, back-up method, and emergency contraception, as needed
- ▶ Provide contact information and future opportunities for follow up, other methods or services
- ▶ Summarize with key points and provide a friendly close

The *closing* section of the **Contraceptive Counseling Process Guide** notes the importance of using the teach-back as a method to confirm client understanding and address any barriers to a successful plan and method use. While the teach-back technique is highlighted in this closing section, this technique can also be used at different times throughout the counseling session to confirm client understanding. Summarizing the key points at the end of the visit offers a chance to remind the client they can return to the clinic at any time for follow up, to change methods, or receive other services.

Why This Module Matters

Through "closing the loop" and reviewing the key details of the chosen contraceptive method and the client's contraceptive plan at the close of the encounter, the provider is able to optimize long term success with the contraceptive method.



Important Terms

As you prepare to deliver this module, familiarize yourself with the following terms:

Teach-back method is a method for ensuring client understanding in a non-shaming way, asking patients to explain in their own words what they need to know or do. The purpose of using the teach-back is to:

- Learn how well you communicated the information to the patient;
- Identify and clarify potential barriers to and/or misinformation about contraceptive methods; and
- Review and confirm the client's plan and any recommended referrals, a backup plan and/or any follow up needed.

Trainer Tip: Before you deliver this final module, think about opportunities for staff to continue to build their skills. Are there other training resources you can share? (See www.fpntc.org for ideas.) Will you make a plan and create tools for peer observation and feedback? Are there other opportunities (i.e., shadowing experienced staff, coaching, mentoring) to evaluate how this training has improved staff skills in client-centered contraceptive counseling?



Training Activities in this Module

Activity 5.1 Using the Teach-Back Method and Closing a Session (60 minutes)

Purpose: Participants will be able to use the teach-back method and other key steps in closing a counseling session to confirm a client's understanding of his or her chosen method and help the client make a plan for method use.

In this activity, you will:

- Introduce the teach-back method to participants and lead a brainstorm on how participants assess their clients' understanding.
- Discuss key elements of closing a session.
- Organize participants into pairs to practice using the teach-back method and helping the client make a plan through an interactive role play.

Activity 5.2 Contraceptive Counseling and Education in Review (45 minutes)

Purpose: Participants will be able to identify, observe and reflect on the key concepts and skills presented throughout the Toolkit training and to reinforce key messages.

In this activity, you will:

- Ask a participant volunteer to join you in reading a script demonstrating a client-centered contraceptive counseling visit.
- Ask all participants to identify key principles, strategies and skills in the demonstration.
- Facilitate a discussion about how the use of different strategies and skills impacted the client encounter and facilitated client-centered decision making.
- Give participants time to reflect on their current strengths in providing client-centered counseling and education and make a plan to address areas they'd like to improve.



General Guidance for All Activities:

- Suggested language for the trainer to say out loud is in italics and shaded. We encourage you to cover these points in your own words and add additional comments relevant to your site.

Example:

This activity is to help us step back and think about what “client-centered” really means and how it’s demonstrated when a person is making a very personal and important life decision.

- We encourage you to be creative with how you present the content within the activities. Have fun, and make it your own! While the content is evidence-based and should be delivered with fidelity, there are many training approaches you could use to help your participants engage with this content. See *Effective Teaching Methods* for ideas, or incorporate your own favorite training strategies!



Activity 5.1 Using the Teach-Back Method and Closing a Session

Purpose

The purpose of this activity is to prepare staff to use the teach-back method and other key steps in closing a counseling session to confirm a client's understanding of his or her chosen method and help the client make a plan for method use.

Who should participate?

Appropriate for all clinic staff who provide family planning services to clients

Especially important for staff who provide contraceptive counseling and education

Time

60 minutes

Preparation

Review the following:

- Module 5 Preview & Preparation
- Activity 5.1 PowerPoint Presentation
- Activity 5.1 Video and/or Demonstration Script
- Activity 5.1 Handouts

Trainer Tip: A key piece of closing the visit is ensuring easy onsite access for a range of methods, along with referrals for methods not available onsite. Learn what methods are available at your site, and talk with leadership as needed to increase the range of methods easily available to clients.



Materials

Handouts:

Make **half as many copies as participants:**

- Role Play Scenarios #1 and #2
- Explaining Contraception Job Aids — **only** Intrauterine Device (IUD), Female Sterilization, and Fertility Based Awareness (FAB) Methods

Presentation:

Load onto laptop and/or print slides as a handout for participants:

- Confirming Understanding and Making a Plan

Video/Demonstration:

Open and test the video link before the training:

- Teach-back Method — Diabetes Medication (skip to the 2:00 mark)

OR

Conduct a brief demonstration with a volunteer, using the sample script:

- Teach-Back Sample Script — Jordana (consider sharing the script with your volunteer in advance)

Supplies:

- Samples of birth control methods to use during role plays
- Large paper to stick/tape to the wall (*optional*)
- Markers (*optional*)
- (*if available for presentation*) Laptop, projector and screen
- (*if available for video*) Internet connection, audio speakers (*optional*)

Resources

Have at least one printed copy available for reference:

- Providing Quality Family Planning Services (QFP): Recommendations of CDC and OPA, Appendix C



Detailed Instructions

1. Introduce the activity:

We're going to practice going through key steps at the close of a session, focusing on confirming your client's understanding of the information you've communicated and helping them make a plan for correct and consistent use of their chosen method.

2. Review the Key Concepts for Participants.

(Optional: Post on large paper or white board.)

This activity will take us through the following Key Concepts that I hope you will remember and apply in your work with clients:

- *Closing the session is a key time to explore and address any additional information needed about the chosen method and potential barriers to use of this method.*
- *Confirming a client's understanding and providing accurate information will help enable the client to use the chosen contraception method correctly and consistently.*
- *Staff should confirm the client's plan for follow-up, including a back-up plan and/or emergency contraception, appropriate to the method chosen.*
- *To support method satisfaction and decrease risk of discontinuation, staff should encourage all clients to return to the clinic at any time with questions or concerns or if they want to change their method.*

3. Begin the PowerPoint Presentation (or use the slides handout).

At a Glance

Introduction

Purpose:

- Practice key steps to close a session

Key Concepts

1. Closing = key time to address additional info needed/potential barriers
2. Accurate info + confirming understanding will support correct and consistent method use
3. Confirm plan for f/u, including back-up plan/EC
4. Encourage client to return any time w/questions or to change methods

Title Slide

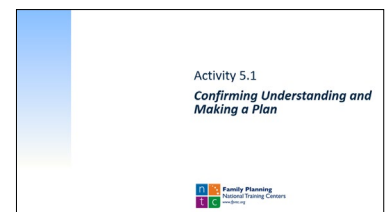

Let's start with the first piece of closing the session: confirming the client's understanding of what you've discussed.

Who is familiar with, or has heard of, the teach-back method?

If anyone has heard of the method, offer them the chance to describe it, if they wish (but don't put them on the spot!).

A highly effective strategy to ensure our clients leave with the information they need is called "teach-back."

Click for the rest of the text on the slide to appear.

- Teach-back is a method for ensuring client understanding in a non-shaming way
- It involves asking patients to explain in their own words what they need to know or do
- It is an indication of how well YOU communicated the information, NOT a "test" of the patient

The teach-back is your chance to check for client understanding and, if necessary, clarify or answer any client misunderstandings or misinformation, Then check the client's understanding again.

Also, teach-back is evidence-based. Two studies (from other areas of health care outside family planning) found that using the teach-back method improves patient-provider communication and patient health outcomes.

What is teach-back (1 of 2)

What is teach-back (2 of 2)

4. Show example of teach-back — either video or in-person demonstration

VIDEO

Let's look at an example. This video clip shows a provider going over instructions for new diabetes meds with a client and then checking the client's understanding. We're going to skip ahead to just few the teach-back portion.

Video link (skip ahead to the **2:00** minute mark):
www.youtube.com/watch?v=DcfPhZu2bi4

DEMONSTRATION

In-person demonstration:

Let's take a look at an example.

Go through the demonstration with a volunteer, using the sample script if needed.

Video or Live Demo

www.youtube.com/watch?v=DcfPhZu2bi4

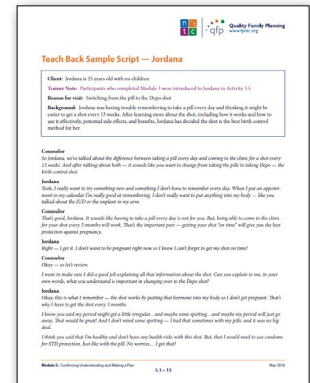

5. Debrief the video/demonstration:

Any general comments or reactions to the video?

How did the provider introduce the teach-back portion of the session? What did (she or he) say?

Debrief Video / Demo

6. Return to the PowerPoint Presentation (or the slides handout)

Why didn't the provider just say, "Tell me what I just told you"?

Invite participants to share responses.

- *By saying, "I want to make sure that I did a good job explaining," it puts the focus on the provider doing a good job, and avoids shaming the client.*

What question did the provider ask?

- *[in the video] "Can you explain to me, in your own words, what the plan is, and what we're going to be doing?"*
- *[in the demonstration] "Can you explain to me, in your own words, what you understand is important in changing over to the Depo shot?"*

Invite participants to give examples of similar questions that would be asked in your clinic setting.

7. Lead a group brainstorm about questions to assess client understanding.

What are some questions that we could use with our clients to check out their understanding?

As the group responds, write the questions on large paper (or ask for a volunteer's help in taking notes). These questions will later serve as a "cheat sheet" in the role play activity.

If anyone offers close-ended questions (e.g., "Do you think you'll ever miss a shot appointment?"), ask the group to turn each closed question into an open-ended question before writing it down.

Sample questions include:

- What will happen if you decide to stop getting the shot?
- What are some "normal" side effects you might expect?
- What are some warning signs? And what would you do if you experienced any?
- What's your plan for talking to your partner about... (whatever)?
- How will you protect yourself from STDs?
- What's the most important thing you learned today?

PowerPoint

Introducing teach-back

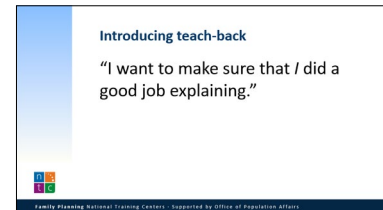

Group Brainstorm

Questions to Check Client Understanding

What will happen if you decide to stop getting the shot?

What are some normal side effects you might expect?

8. **Return to the PowerPoint Presentation** (or the slides handout)

Remember — *Teach-back is all about the client owning the information, by saying it in his or her own words.*

Another tool we can use to reinforce teach-back and to help the client own the information is to tailor patient education materials for that specific client.

How many of you write all over your patient education materials, training tools, etc.? Good for you! This personalizes it and makes it much more likely the client will take it home and refer to it.

So why do you think teach-back is so important?

Get a few responses before moving to the next slide.

In a 2003 assessment of Americans' health literacy, among patients who could recall their doctor's instructions, nearly half of the patients remembered the information incorrectly.

Trainer Tip: Source included on References slide at end.

Another survey found that up to 80% of clients said they forgot what their doctor said to do after leaving the office.

Trainer Tip: Source included on References slide at end.

On the other hand, numerous studies have found that taking the few minutes to use teach-back results in client's increased understanding and greater retention of information provided.

Trainer Tip: Tailor or eliminate the following statement as needed depending on your agency's practices.

Also, if we can confirm our client's understanding, then we can use a check box or written statement in place of a written method-specific informed consent form. (QFP, page 13)

PowerPoint

The message can be tailored...

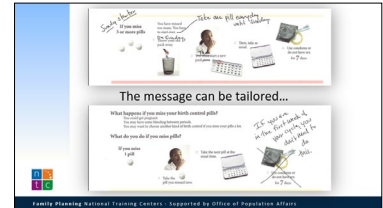

**Why use teach-back?
(1 of 2)**

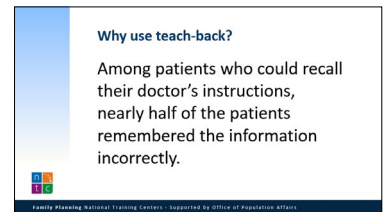

**Why use teach-back?
(2 of 2)**

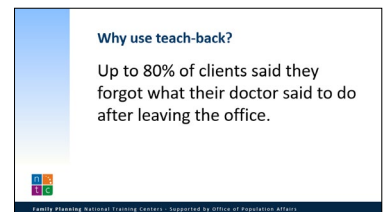

What if your client isn't able to remember everything?

Your responsibility as the provider is to explain again, and in different ways, to help the client clearly understand the important information about their chosen method.

You might restate what you've already said, but this time:

- Use simpler language.
- Take more/longer pauses, with more time for questions; for example, when discussing what to do if you miss a pill, allow extra time for questions.
- Break up the information into smaller chunks; for example, when confirming understanding of consistent and correct method use, ask specific questions — 1) "How will you use it?" 2) "What will you do if you have spotting or bleeding?" 3) "What will you do if you forget..?" etc.

Are there other strategies you would add?

Once you've restated the instructions, it's important to reassess the client's understanding through asking them again to repeat the instructions back to you in their own words.

Pay close attention to the client's words and body language to gauge their level of comfort with the conversation and the next steps they're going to take.

When should we be using the teach-back method?

While we've been talking about using it at the end of a client visit, we really need to use it throughout a visit, especially with a young client, or a complicated visit involving lots of new information.

**What if... ?
(1 of 2)**

What if ...?

Restate, but ...

- Use simpler language
- Take more time (longer pauses) with more time for questions.
- Break up information into smaller pieces.

Family Planning National Training Center - supported by Office of Population Affairs

**What if... ?
(2 of 2)**

What if ... ?

Reassess

Ask open-ended questions until you and your client feel confident she or he understands needed information

Family Planning National Training Center - supported by Office of Population Affairs

When to use teach-back?

When to use teach-back?

Contraceptive Counseling Process

Process

- Beginning and throughout
- Middle
- Closing

Family Planning National Training Center - supported by Office of Population Affairs

Returning to our steps for closing the session, here are some key things to cover with the client:

- We've talked about teach back, which is a helpful tool both for confirming understanding and summarizing key points for the client to remember at the close of a session
- You also want to help the client solidify a plan to use their method.

What do you think the plan should include?

Pause for responses before clicking to show slide text.

- How the client will access their chosen method; ideally you'll be able to provide it onsite, but you may need to give them a referral;
- How the client plans to use their chosen method effectively – that is, consistently and correctly;
- What the client should do if they have questions or problems; and
- How to use back-up and/or emergency contraception
- You also will want to provide your contact information and any other information related to follow-up appropriate for that particular client and their chosen method. This should include a genuine invitation to return to see you at any time for any reason, including if they are wanting to change methods.
- Lastly, provide any additional services and/or referrals needed to address any other stated client needs.

Any other questions or comments before we practice?

References & Resources and Contact Information are included at the end of each presentation.

Key Elements in a Closing Session

Key Elements in Closing a Session

- Use teach-back to confirm your client's understanding
- Address any possible barriers to successful method use
- Confirm your client's plan for:
 - Access to the method (ideally onsite, or by referral)
 - Effective method use – consistently & correctly
 - What to do if they have questions or problems
 - How to use back-up/emergency contraception
- Provide contact information for follow up, if the client wishes to change methods, or to receive other services or referrals
- Summarize with the client the key points to remember

Family Planning National Training Center | Supported by Office of Population Affairs

Questions / Comments

Questions/Comments

Family Planning National Training Center | Supported by Office of Population Affairs

9. Ask participants to form pairs for a practice activity.

Instruct the pairs to decide who will be the “counselor” and who will be the “client.” Let the pairs know that every person will get a chance to play both roles.

10. Give each “counselor” a copy of Role Play 1.

11. Hand out copies of the “Intrauterine Device (IUD)” Explaining Contraception Job Aids and a sample hormonal IUD.

12. Give the following instructions to the pairs:

- For those of you playing the “counselor,” your scenario sheet includes background information on the client and the session up to that point. During the session, you can use the job aid and the method sample as references or tools.
- For those of you playing the “client,” don’t give a perfect summary right away during the teach-back; give the “counselor” a chance to practice restating information and using open-ended questions like the ones we brainstormed earlier.

Pairs for Practice

- Each pair chooses roles — client and counselor

Counselor Description — Role Play 1

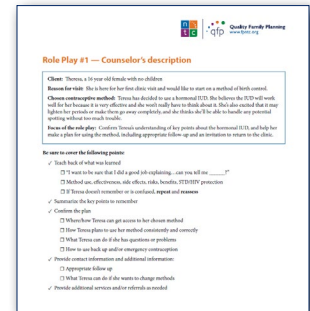

IUD Explaining Contraception Job Aids & Sample Method

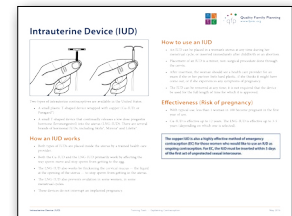

Practice Instructions

- Counselors — see background info on client and session; use job aid and method sample as needed
- Clients — don’t give a perfect answer right away!

13. Instruct participants to begin the role play sessions.

Let pairs know that they'll have about 5 minutes for this first role play.

14. After about 5 minutes, call “stop” and lead a quick large group debrief.

Ask the “clients”:

- *What did your partners do that was helpful?*

Ask the “counselors”:

- *How did that go? How easy/hard was it?*

15. Ask the pairs to reverse roles for Role Play 2. Give the new “counselors” a copy of Role Play 2.

16. Hand out new Explaining Contraception Job Aids and sample methods, for Female Sterilization and the Fertility Awareness Based (FAB) Methods.

Practice Instructions

~5 minutes

Quick Debrief

- Clients — what was helpful?
- Counselors — how did it go? How easy/hard was it?

Switch Roles for Role Play 2

- Pairs switch roles

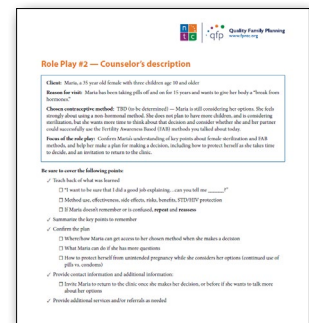

Female Sterilization and FAB Methods

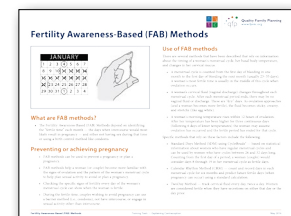
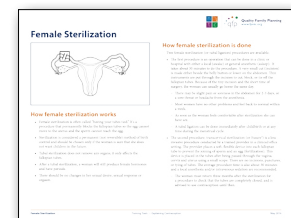



17. After about 5 minutes, call “stop” and lead another quick debrief.

Ask the “clients”:

- *What did your partners do that was helpful?*

Ask the “counselors”:

- *How did that go? How easy/hard was it?*

18. Lead a final full group discussion, asking questions such as:

- *What final questions or comments do you have about closing the session — either using teach-back, or helping the client make a plan?*
- *How might you incorporate teach-backs into your practice?*
- *What are some ways you/we can support one another to build our skills in effectively closing a contraceptive counseling and education session?*

19. Wrap up the activity, highlighting the following points:

- *Taking time to close the session — using the teach-back method and helping clients make a plan — is useful to clients, by helping them to most effectively use their chosen methods, and follow other critical instructions.*
- *It’s also useful to us, by increasing the likelihood that clients will know when they do and don’t need to return to the clinic.*
- *Thinking of each counseling session as having a beginning, middle and closing can be a helpful structure as we think about how to cover a lot of information, sometimes in a very short time. We should always take some time for meaningful closure of a conversation before we end our time with a client.*
- **Thank you for your participation in this practice** — especially for those of you who may have been asked to talk about methods you’re less familiar with. Through continued practice, we can all grow our skills in providing the highest quality client-centered care.

Quick Debrief

- Clients — what was helpful?
- Counselors — how did it go?
How easy/hard was it?

Full Group Discussion

- Final questions/comments on teach-back, helping client make a plan?
- How will you use teach-back?
- How can we support each other with these skills?

Wrap-Up Activity 5.1 Complete



Teach Back Sample Script — Jordana

Client: Jordana is 25 years old with no children

Trainer Note: Participants who completed Module 3 were introduced to Jordana in Activity 3.5

Reason for visit: Switching from the pill to the Depo shot

Background: Jordana was having trouble remembering to take a pill every day and thinking it might be easier to get a shot every 13 weeks. After learning more about the shot, including how it works and how to use it effectively, potential side effects, and benefits, Jordana has decided the shot is the best birth control method for her.

Counselor

So Jordana, we've talked about the difference between taking a pill every day and coming to the clinic for a shot every 13 weeks. And after talking about both — it sounds like you want to change from taking the pills to taking Depo — the birth control shot.

Jordana

Yeah, I really want to try something new and something I don't have to remember every day. When I put an appointment in my calendar, I always remember to go. I don't really want to put anything into my body — like you talked about the IUD or the implant in my arm.

Counselor

It sounds like remembering something every day is not for you. But, remembering appointments in your calendar works well. That's good because being on time for the Depo shot is really important for protection against pregnancy.

Jordana

Right — I get it. I don't want to be pregnant right now so I know I can't forget to get my shot on time!

Counselor

Okay — so let's review. I want to make sure I did a good job explaining all that information about the shot. Can you tell me, in your own words, what you understand is important in changing over to the Depo shot?

Jordana

Okay, this is what I remember — the shot works by putting that hormone into my body so I don't get pregnant. That's why I have to get the shot every 3 months.

Counselor

That's right. That is the most important part about using Depo. So, tell me about what might happen with your periods?

Jordana

I know you said my period might get a little irregular...and maybe some spotting And I don't mind some spotting — I had that sometimes with my pills, and it was no big deal. ...and maybe my period will just go away. That would be great!



Counselor

That's right. Sounds like you have a good understanding of what to expect. What about STD protection?

Jordana

I know that I would need to use condoms for STD protection. Just like with the pill. No worries... I got that!

Counselor

And what did we talk about happens when you decide to stop the shot?

Jordana

Um... that my period might take a while to come back — how long did you say?

Counselor

Well your period could come back right away, or it could take several months or even a year or longer — each woman is different.

Jordana

Oh, OK that's not a problem. Like I said — I'm not going to get pregnant for a long time.

Counselor

Since you're not planning a pregnancy, remind me what you'll do if you're late for your shot?

Jordana

Well since I can get pregnant when I miss a shot, if I miss my appointment, I'll have to use condoms until I get the shot. And I also have emergency contraception. I think you told me it takes 7 days to start working, so I would use condoms for 7 days after the shot. Is that right?

Counselor

Yes, that's exactly right. Now, let's talk about how you want to change from taking the pills to the shot.

Jordana

Well, I haven't missed any pills this month. I'll be all done with my pack on this coming Saturday, so I'd like to get the shot before my pills run out. Can I get the shot today while I'm here and then stop my pills?

Counselor

Sure, you can get the shot today and you're right — once you've had the shot you'll have full protection from pregnancy.

Jordana

So, that means I can stop taking my pills tonight?

Counselor

That's right. But before you go, I just want to make sure you know what to do if you have questions about the shot or if you have problems or if you want to change methods in the future.

Jordana

I have the clinic number here — I will call you if I have any questions.

Counselor

Ok... good, what other questions do you have before you go for your shot?



Role Play #1 — Counselor's description

Client: Theresa, a 16 year old female with no children

Reason for visit: She is here for her first clinic visit and would like to start on a method of birth control.

Chosen contraceptive method: Teresa has decided to use a hormonal IUD. She believes the IUD will work well for her because it is very effective and she won't really have to think about it. She's also excited that it may lighten her periods or make them go away completely, and she thinks she'll be able to handle any potential spotting without too much trouble.

Focus of the role play: Confirm Teresa's understanding of key points about the hormonal IUD, and help her make a plan for using the method, including appropriate follow-up and an invitation to return to the clinic.

Be sure to cover the following points:

- ✓ Teach back of what was learned
 - "I want to be sure that I did a good job explaining...can you tell me _____?"
 - Method use, effectiveness, side effects, STD/HIV protection
 - If Teresa doesn't remember or is confused, **repeat** and **reassess**
- ✓ Summarize the key points to remember
- ✓ Confirm the plan
 - Where/how Teresa can get access to her chosen method
 - How Teresa plans to use her method consistently and correctly
 - What Teresa can do if she has questions or problems
 - How to use back up and/or emergency contraception
- ✓ Provide contact information and additional information:
 - Appropriate follow up
 - What Teresa can do if she wants to change methods
- ✓ Provide additional services and/or referrals as needed



Role Play #2 — Counselor's description

Client: Maria, a 35 year old female with three children age 10 and older

Reason for visit: Maria has been taking pills off and on for 15 years and wants to give her body a “break from hormones.”

Chosen contraceptive method: TBD (to be determined) — Maria is still considering her options. She feels strongly about using a non-hormonal method. She does not plan to have more children, and is considering sterilization, but she wants more time to think about that decision and consider whether she and her partner could successfully use the Fertility Awareness Based (FAB) methods you talked about today.

Focus of the role play: Confirm Maria's understanding of key points about female sterilization and FAB methods, and help her make a plan for making a decision, including how to protect herself as she takes time to decide, and an invitation to return to the clinic.

Be sure to cover the following points:

- ✓ Teach back of what was learned
 - “I want to be sure that I did a good job explaining...can you tell me _____?”
 - Method use, effectiveness, side effects, STD/HIV protection
 - If Maria doesn't remember or is confused, **repeat** and **reassess**
- ✓ Summarize the key points to remember
- ✓ Confirm the plan
 - Where/how Maria can get access to her chosen method when she makes a decision
 - What Maria can do if she has more questions
 - How to protect herself from unintended pregnancy while she considers her options (continued use of pills vs. condoms)
- ✓ Provide contact information and additional information:
 - Invite Maria to return to the clinic once she makes her decision, or before if she wants to talk more about her options
- ✓ Provide additional services and/or referrals as needed



See Appendix C
for all other handouts
referenced in this activity.



Activity 5.2 Contraceptive Counseling and Education in Review

Purpose

The purpose of this activity is to identify, observe and reflect on the key concepts and skills presented throughout the Toolkit training and to reinforce key messages.

Who should participate?

Appropriate for all clinic staff who provide family planning services to clients

Especially important for staff who provide contraceptive counseling and education

Time

45 minutes

Preparation

Review the following:

- Module 5 Preview & Preparation
- Case Study Script

Trainer Tip: Consider selecting a volunteer ahead of time and sharing the case study script in advance, to allow the volunteer to prepare and improve the case study demonstration.

Materials

Handouts:

Make one copy for each participant:

- Contraceptive Counseling Process Guide

Supplies:

- Case Study Script (Trainer and Client versions)
- Birth Control Method Options chart* (1 copy for case study demo)
- Large paper to stick/tape to the wall or whiteboard
- Markers
- Scratch paper and pens

Resources

- Principles for Providing Quality Counseling
- OARS Model — Essential Communication Skills
- Seven Strategies for Effective Communication
- Client-Centered Decision Making Observation Checklist (Module 4)

* You may use a different birth control method chart if the typical use effectiveness rates match those on the Birth Control Method Options chart.

Detailed Instructions

1. Introduce the activity:

We've covered a lot of material throughout these training activities and learned a number of useful models for implementing quality contraceptive counseling and education. To make sure we're all on the same page, and can still remember what we've learned, we're going to review our key principles, skills, and strategies and apply them to a complete counseling scenario.

2. Review key points from the 5 modules as a full group.

Take notes on large paper or whiteboard.

See what the group comes up with first for each question, then highlight additional key principles/skills/strategies as needed.

- *We talked in Module 1 about the key principles of quality, client-centered counseling... what do you remember?*
- *What communication and rapport-building skills do you remember from Module 2?*
- *Module 3 was all about education... what are some strategies for effective education?*
- *What are the important things you remember about interactive decision making from Module 4?*
- *What are the key things to go over with a client when closing the visit (Module 5)?*

3. Introduce the demonstration.

In earlier modules, you've had practice in observing client-provider interactions with a particular focus, such as identifying all of the effective education strategies the counselor uses.

Now you're going to have an opportunity to observe a complete, integrated contraceptive counseling session, looking for any key principles, strategies or skills that the counselor demonstrates. The goal is not to see who can identify the most strategies, but rather to see all of these skills come together in a complete session and reflect on how they facilitate client-centered decision making.

We don't have a structured checklist, but I encourage you all to take notes of what you observe.

At a Glance

Introduction

Purpose:

- Review key principles, skills, and strategies — applied to a complete counseling scenario

Review Key Points

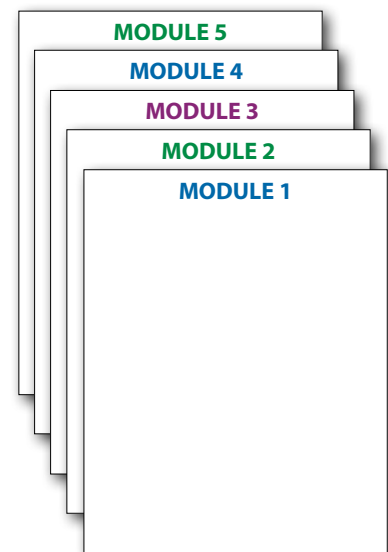

Demonstration

- Will observe a complete, integrated counseling session
- Look for key principles, strategies, or skills
- Take notes!

- Distribute scratch paper and pens so that participants can take notes.

- Do the demonstration, selecting a volunteer to play the client, Mia. See the Case Study script — Trainer and Client versions at the end of the activity.

- Debrief and discuss the demonstration.

- Any comments or observations?*
- What did you like about this encounter — what was effective?*
- What would you have done differently?*
- How would you describe the “client-centeredness” of this session? What did the counselor do that was (or wasn’t) client-centered?*
- What did you notice about the flow of the session...opening, closing, and in between? What stood out in the beginning, middle and closing sections?*

Scratch Paper & Pens

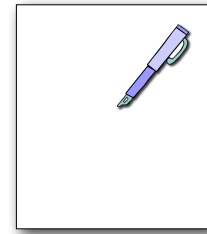

Demonstration

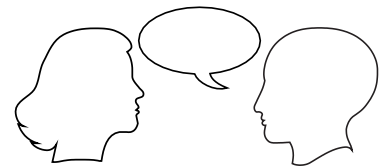

Full Group Debrief

- General observations?
- What was effective?
- What would you do differently?
- What was/wasn't client-centered?
- What did you notice in the beginning, middle and closing?

7. **(Optional) Lead a more detailed debrief focused on concepts and skills from each module.**

Return to the notes from your review at the beginning of activity. Ask participants what they noticed within the demonstration related to the content of each module.

Optional Detailed Debrief

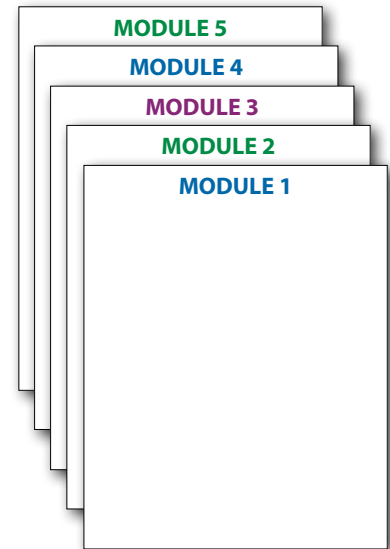

8. **Ask participants to quietly reflect for a moment on what they learned.**

Ask participants to think about what they observed and learned during this activity and throughout all the other training activities they've participated in.

Distribute additional scratch paper and ask all participants to take less than 5 minutes to quickly write down (for their own personal reminder) what they plan to do differently when counseling clients on birth control options in a client-centered way.

Individual Reflection

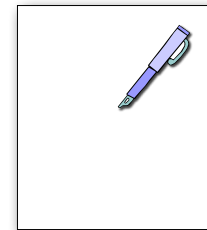

9. **After participants are done writing, wrap up the activity:**

- *Thank you for your participation in this activity.*
- *Our challenge and our goal as professionals is to provide effective client-centered contraceptive services.*
- *Doing this consistently and well is very possible, but takes constant attention and self-reflection, as well as ongoing education, and most importantly, practice!*
- *I encourage you to explore additional training activities and resources by visiting the Family Planning National Training Center's website, www.fpntc.org, and to support and encourage one another in continually striving to improve our skills and services.*

**Wrap-Up
Activity 5.2 Complete**





Case Study Script — Trainer Copy (as “Kate”)

Client: Mia

Mia is an 18 year old, single woman who is planning to attend college in the fall and has decided to come to the clinic for contraception. Reviewing her medical and social history, we know that she has been sexually active in the past and has used condoms for both pregnancy and STD/HIV prevention. She has no apparent medical conditions that would prevent her from using any of the birth control methods. She is undecided about what method she wants today.

Trainer Tip: If participants completed Activity 4.3, Personalized and Interactive Client Assessment, you could say: We first met Mia in Module 4, where we had an opportunity to develop assessment questions to learn more about her and what was important to her in a birth control method.

Name	Script	Skills (for Trainer Reference during debrief)
Counselor (Kate)	Hi Mia, my name is Kate. It looks like this is your first visit to our clinic.	Principle 1 Welcoming (rapport building)
Client (Mia)	Yep...first time.	
Kate	Well — I want to welcome you ... sometimes it's a big step to come into a clinic you've never visited before. (pause) So — before we start — maybe you have a question or two for me?	Welcoming (rapport building) Open-ended question
Mia	Well...I'm just wondering what's going to happen today. Mostly I just came in to talk about birth control.	
Kate	Great question, Mia. We're glad to see you, and I can tell you a little about your visit today. First, we tell all of our clients about our policy of confidentiality. What that means is that everything you tell us and what we talk about is private — it's just between you and me and other clinic staff on a "need to know" basis. The only reason it might change is if you tell me that someone has hurt you, or you have — or you might — hurt yourself or someone else. In that case I'd need to talk to others who can help. Any question about that...?	Principle 1 Affirmation General information about the clinic visit
Mia	No — that makes sense.	



<p>Kate</p>	<p>Good — as we talk, if you have any questions please let me know.</p> <p>Like you said a minute ago, we can talk about the birth control methods available and what method you might like to try.</p> <p>If you decide on a method that needs a prescription, you'll see a clinician today. Or, if you don't decide on a method today we can talk about how to make an appointment later.</p> <p>What questions about birth control do you have?</p>	<p>Principle 1</p> <p>Reflective listening</p> <p>General information about the clinic visit</p> <p>Open-ended question</p>
<p>Mia</p>	<p>I'm not sure I need birth control right now — I'm not seeing anyone. But I just thought I'd at least get more information than what my friends tell me.</p>	
<p>Kate</p>	<p>Good point — our friends can be a good resource, but information that fits you is best.</p> <p>The history forms you filled out give me some general information about you — and I have a lot of information about all the methods. The most important thing is that you find a method that is safe, effective and is right for you at this time in your life.</p>	<p>Principle 1</p> <p>Reflective listening</p> <p>Tailoring information</p>
<p>Mia</p>	<p>Thanks — I've used condoms in the past and they were okay. I haven't really been seeing anyone lately but I just graduated and I'm going to college in a couple of months. I thought maybe I need a more effective method. I really don't want to get pregnant right now!</p>	
<p>Kate</p>	<p>Hmmm, smart — sounds like you're pretty good at making a plan for yourself — going to college, coming to the clinic today, really just taking care of your life and your health.</p> <p>And you've used condoms before which are great protection against pregnancy <u>and</u> STDs including HIV.</p>	<p>Principle 2</p> <p>Affirmation (rapport building)</p> <p>Clear, easy to understand</p>
<p>Mia</p>	<p>I guess. I'm really just a bit nervous about college and it seemed like coming into a clinic <u>now</u> might be better to do — not in 2 or 3 months when I'll be crazy busy.</p>	
<p>Kate</p>	<p>Good point... and good planning.</p> <p>From what you said a moment ago, it sounds like you aren't planning a pregnancy anytime soon. What thoughts do you have about planning a pregnancy in the future?</p>	<p>Principle 1</p> <p>Affirming</p> <p>Principle 2</p> <p>Reflective listening</p> <p>Reproductive life planning (RLP)</p>

<p>Mia</p>	<p>Oh yeah — I do want kids. But not until I’m done with school and meet someone I want to have a child with. My guess is that’s quite a few years off....</p> <p>So for now — birth control it is!</p> <p>I’ve heard a lot about a bunch of different methods. I’ve talked to my friends and looked on the Internet — but I don’t know how to decide. How do I know what method is best?</p>	
<p>Kate</p>	<p>That’s a question a lot of people ask! We know that women who are most satisfied with their method — and continue using it — are the ones who make that choice for themselves.</p> <p>Shall we take a minute to look at this chart that shows all the methods that are available?</p> <p><i>(shows the Birth Control Method Options chart to Mia)</i></p>	<p>Principle 2</p> <p>Affirming (rapport building)</p> <p>Offering full range of methods</p>
<p>Mia</p>	<p>Sure <i>(pauses — looks at the chart)</i></p> <p>Hmmm — lots of options to think about...</p>	
<p>Kate</p>	<p>You’re right — although you just said you’d like to plan a pregnancy sometime in the future — so you don’t have to think about sterilization points to the left side of the chart).</p>	<p>Affirming (rapport building)</p> <p>Easy to understand; tailored information</p>
<p>Mia</p>	<p>Yeah — I don’t need to think about sterilization. And I mostly know about condoms ‘cause that’s what I’ve used in the past. They’re fine — and I’d always use them if I need something quick. I just want something more effective.</p>	
<p>Kate</p>	<p>So when we talk about effectiveness we can also talk about whether something’s easy to use. These methods on the left side of the chart are the most effective methods because once they’re in place there’s not much you need to do or remember.</p> <p>So what do you think?</p>	<p>Principles 2 & 4</p> <p>Clear and easy to understand</p> <p>Open-ended question</p>
<p>Mia</p>	<p>I do know that one of my friends got an IUD and she said it really hurt when they put it in. She also said her periods were horrible and she just kept spotting. After about 2 months she had it taken out.</p>	
<p>Kate</p>	<p>Most women do have some pain when the IUD is placed, although other women barely feel it. And lots of women have changes in their periods with the IUD. For some it’s so uncomfortable that they do have it removed like your friend did. But many women say the spotting is pretty light and it usually goes away after a few months. Each woman is different, so there’s no way to know how your body will react without trying it.</p>	<p>Principle 1</p> <p>Reflective listening & summarizing</p> <p>Principles 3 & 4</p> <p>Information tailored; interactive, personalized</p>



Mia	So how do I decide?	
Kate	Here are a couple of questions for you to think about: First — Thinking about having an IUD placed — How do you manage any short term pain or discomfort? Second — What would it be like for you to have irregular or heavier periods?	Principle 2 Open-ended questions
Mia	Well, I do sometimes get cramps with my period. I just take aspirin and rest for a day. It goes away. I'm not too bad with short term pain — especially if I know why it's happening... My periods are pretty light. It might be annoying to have spotting. How long would it last?	
Kate	Again, each person is different and it's not possible to know how your body will react to the IUD. The spotting or irregular bleeding could last for a month, or for several months, or longer. With one type of IUD your periods would probably get lighter or they might go away completely. With the other type of IUD, your periods would probably be a bit heavier and more painful at first.	Principle 3 Tailored information Clear, easy to understand
Mia	I wouldn't want the one with heavier periods. I'd rather have the one with lighter or no periods. I could spend less on tampons (<i>smiles</i>).	
Kate	Right — (<i>laughs</i>) Another easy-to-use and effective method is the implant (<i>points to the chart</i>) — what do you know about it?	Clear, easy to understand Tailored to client
Mia	I've heard of it — but I don't think I want it in my arm where someone might see it. When I go to school I'm going to meet a bunch of new people. I don't want them asking — "So, what's that in your arm?"	
Kate	That's good to know. You're already talking about what's important to you in a birth control method. It sounds like "privacy" is another thing that's important.	Reflective listening
Mia	Yes — privacy. I don't want people in my business. And I want it really easy and effective! When I look at this chart and think about the patch — that's not as private. The ring and the pills also don't seem really private. Someone could see them — plus I'm not sure I'd remember to use them like I should.	
Kate	So you want an easy method to use, one that's private, and one that you know what the possible side effects might be. What else is important?	Reflective listening/ summarizing Open-ended question
Mia	I don't know — what should be important?	



Kate	Well, when I talk with some people they think about health risks that are related to a method.	Principle 3 Interactive & engaging Tailored information
Mia	I definitely want a method that is safe.	
Kate	All of these methods are safe. That's why we ask you medical history questions — so we can make sure that the method you choose is safe for you. Right now, your medical history gives us no worry about risk with any of the methods.	Principle 2 Assess, personalize, tailored information
Mia	Well, I'm glad I don't have to worry about my health. <i>(smiles)</i>	
Kate	Often people ask me about what their partner might think about the method and also about protection from STDs and HIV.	
Mia	I don't have a boyfriend right now, so I don't have to worry about what he thinks <u>or</u> about STDs. Anyway — I've used condoms in the past so I guess I'd just make sure I'd have them with me.	
Kate	Good planning <i>(smiling)</i> . What other questions do you have about the IUD?	Affirming (rapport building)
Mia	How long does the IUD stay in your body?	
Kate	The IUD that you were thinking about — the hormonal IUD — can last up to 5 years.	Easy to understand
Mia	Oh, I don't know if I want something for that long. I might want to take it out sooner. And I might not like it.	
Kate	You can have it taken out any time you want. Some women do decide to have the IUD removed before it expires. Sometimes it's because they want to get pregnant and other times it's because they don't like it. You can always change your mind about any of these methods on the chart except sterilization. The IUD can be removed at any time.	Easy to understand and tailored to client
Mia	Oh that's good.	
Kate	So Mia — We've talked about several of the methods on this chart. And you've had some great questions. What else do you want to know about any of these methods?	Principle 3 & 4 Affirming (rapport) Summarizing Open ended question Tailored to client



Mia	Well, this is a lot of information. I think I might want to get an IUD. But I'm not quite sure. Maybe I'll do some more thinking and make a decision before I go off to school in a couple of months.	
Kate	That sounds like a plan to me. To help in your decision, I'll give you printed information about the IUD options we have in our clinic. It gives you instructions about how to make an appointment if you want to come in for an IUD placement. (hands her printed materials)	Principle 3 Affirming (rapport) Tailored information
Mia	Thanks. This will help.	
Kate	You said that you'd use condoms if you need them soon. How comfortable would you be asking a new partner to use condoms?	Principle 3 Tailored information Open-ended question
Mia	Well, fine I think. My old boyfriend and I used condoms every time we were together. It wasn't a problem. I told him from the beginning that I wasn't willing to take any chances on getting pregnant. I'd do the same thing with anyone.	
Kate	So it sounds like you feel comfortable using condoms and also talking to a new partner about them. What would you do if the condom broke or came off?	Affirming Open ended question
Mia	I'm not sure. That never happened.	
Kate	Okay — What have you heard about Emergency Contraception?	Open ended question
Mia	Oh yeah — my girlfriend was worried she might get pregnant after a condom broke. She came here and got emergency pills.	
Kate	That's great. You know you can come here. You can also go to a local pharmacy for emergency contraception. The main thing to remember is that the sooner you use it, the more effective it is. In this clinic, we can give you a supply of emergency contraceptive pills today so that you have them on hand if you need them.	Summarizing Tailored information
Mia	Thanks — that's good to know. I think I'll wait on that because there really isn't anyone in my life now. But if anything changes I'll come in and get them.	
Kate	Okay, so let's talk about your plan for now: You want a method that's easy, private and really effective so you're going to think about an IUD before you go to college in the fall. You're going to read over the information about the different IUDs and call for an appointment when you decide. Does that sound right?	Summarizing Moving to closing



Mia	Yeah, that's right. I'm thinking that if I decide to get an IUD I should get it soon so I'll still be here in town and can come back and see you if I have any problems.	
Kate	That sounds good. And you have the written instructions about how to make an appointment if you want to come in for an IUD or for any method you decide you want. In the meantime, if something changes and you do have sex, you have condoms.	Tailored information
Mia	Yes, that's right.	
Kate	Just to make sure I explained clearly about taking Emergency Contraception, tell me what you remember.	Principle 5 Teach back
Mia	Well, you said I should use it as soon as possible, so I would take it right away. If I already had some emergency pills, that would be no problem. Or I would go to a pharmacy.	
Kate	That's right. And if you need them, we can give you condoms before you leave today.	Principle 5 Tailored information
Mia	No — I have some at home. I'm okay for now. But thanks... I'll see you again soon.	
Kate	Ok Mia — Bye for now. I look forward to seeing you again. Call us anytime!	Closing



Case Study Script — Client Copy (“Mia”)

Mia is an 18 year old, single woman who is planning to attend college in the fall and has decided to come to the clinic for contraception. Reviewing her medical and social history, we know that she has been sexually active in the past and has used condoms for both pregnancy and STD/HIV prevention. She has no apparent medical conditions that would prevent her from using any of the birth control methods. She is undecided about what method she wants today.

Name	Script
Counselor (Kate)	Hi Mia, my name is Kate. It looks like this is your first visit to our clinic.
Client (Mia)	Yep...first time.
Kate	Well — I want to welcome you ... sometimes it's a big step to come into a clinic you've never visited before. (pause) So — before we start — maybe you have a question or two for me?
Mia	Well...I'm just wondering what's going to happen today. Mostly I just came in to talk about birth control.
Kate	Great question, Mia. We're glad to see you, and I can tell you a little about your visit today. First, we tell all of our clients about our policy of confidentiality. What that means is that everything you tell us and what we talk about is private — it's just between you and me and other clinic staff on a “need to know” basis. The only reason it might change is if you tell me that someone has hurt you, or you have — or you might — hurt yourself or someone else. In that case I'd need to talk to others who can help. Any question about that...?
Mia	No — that makes sense.



Kate	<p>Good — as we talk, if you have any questions please let me know.</p> <p>Like you said a minute ago, we can talk about the birth control methods available and what method you might like to try.</p> <p>If you decide on a method that needs a prescription, you'll see a clinician today. Or, if you don't decide on a method today we can talk about how to make an appointment later.</p> <p>What questions about birth control do you have?</p>
Mia	<p>I'm not sure I need birth control right now — I'm not seeing anyone. But I just thought I'd at least get more information than what my friends tell me.</p>
Kate	<p>Good point — our friends can be a good resource, but information that fits you is best.</p> <p>The history forms you filled out give me some general information about you — and I have a lot of information about all the methods. The most important thing is that you find a method that is safe, effective and is right for you at this time in your life.</p>
Mia	<p>Thanks — I've used condoms in the past and they were okay. I haven't really been seeing anyone lately but I just graduated and I'm going to college in a couple of months. I thought maybe I need a more effective method. I really don't want to get pregnant right now!</p>
Kate	<p>Hmmm, smart — sounds like you're pretty good at making a plan for yourself — going to college, coming to the clinic today, really just taking care of your life and your health.</p> <p>And you've used condoms before which are great protection against pregnancy <u>and</u> STDs including HIV.</p>
Mia	<p>I guess. I'm really just a bit nervous about college and it seemed like coming into a clinic <u>now</u> might be better to do — not in 2 or 3 months when I'll be crazy busy.</p>
Kate	<p>Good point... and good planning.</p> <p>From what you said a moment ago, it sounds like you aren't planning a pregnancy anytime soon. What thoughts do you have about planning a pregnancy in the future?</p>



Mia	<p>Oh yeah — I do want kids. But not until I'm done with school and meet someone I want to have a child with. My guess is that's quite a few years off....</p> <p>So for now — birth control it is!</p> <p>I've heard a lot about a bunch of different methods. I've talked to my friends and looked on the Internet — but I don't know how to decide. How do I know what method is best?</p>
Kate	<p>That's a question a lot of people ask! We know that women who are most satisfied with their method — and continue using it — are the ones who make that choice for themselves.</p> <p>Shall we take a minute to look at this chart that shows all the methods that are available?</p> <p><i>(shows the Birth Control Method Options chart to Mia)</i></p>
Mia	<p>Sure <i>(pauses — looks at the chart)</i></p> <p>Hmmm — lots of options to think about...</p>
Kate	<p>You're right — although you just said you'd like to plan a pregnancy sometime in the future — so you don't have to think about sterilization points to the left side of the chart).</p>
Mia	<p>Yeah — I don't need to think about sterilization. And I mostly know about condoms 'cause that's what I've used in the past. They're fine — and I'd always use them if I need something quick. I just want something more effective.</p>
Kate	<p>So when we talk about effectiveness we can also talk about whether something's easy to use. These methods on the left side of the chart are the most effective methods because once they're in place there's not much you need to do or remember.</p> <p>So what do you think?</p>
Mia	<p>I do know that one of my friends got an IUD and she said it really hurt when they put it in. She also said her periods were horrible and she just kept spotting. After about 2 months she had it taken out.</p>
Kate	<p>Most women do have some pain when the IUD is placed, although other women barely feel it. And lots of women have changes in their periods with the IUD. For some it's so uncomfortable that they do have it removed like your friend did. But many women say the spotting is pretty light and it usually goes away after a few months. Each woman is different, so there's no way to know how your body will react without trying it.</p>



Mia	So how do I decide?
Kate	Here are a couple of questions for you to think about: First — Thinking about having an IUD placed — How do you manage any short term pain or discomfort? Second — What would it be like for you to have irregular or heavier periods?
Mia	Well, I do sometimes get cramps with my period. I just take aspirin and rest for a day. It goes away. I'm not too bad with short term pain — especially if I know why it's happening... My periods are pretty light. It might be annoying to have spotting. How long would it last?
Kate	Again, each person is different and it's not possible to know how your body will react to the IUD. The spotting or irregular bleeding could last for a month, or for several months, or longer. With one type of IUD your periods would probably get lighter or they might go away completely. With the other type of IUD, your periods would probably be a bit heavier and more painful at first.
Mia	I wouldn't want the one with heavier periods. I'd rather have the one with lighter or no periods. I could spend less on tampons (<i>smiles</i>).
Kate	Right — (<i>laughs</i>) Another easy-to-use and effective method is the implant (<i>points to the chart</i>) — what do you know about it?
Mia	I've heard of it — but I don't think I want it in my arm where someone might see it. When I go to school I'm going to meet a bunch of new people. I don't want them asking — "So, what's that in your arm?"
Kate	That's good to know. You're already talking about what's important to you in a birth control method. It sounds like "privacy" is another thing that's important.
Mia	Yes — privacy. I don't want people in my business. And I want it really easy and effective! When I look at this chart and think about the patch — that's not as private. The ring and the pills also don't seem really private. Someone could see them — plus I'm not sure I'd remember to use them like I should.
Kate	So you want an easy method to use, one that's private, and one that you know what the possible side effects might be. What else is important?
Mia	I don't know — what should be important?



Kate	Well, when I talk with some people they think about health risks that are related to a method.
Mia	I definitely want a method that is safe.
Kate	All of these methods are safe. That's why we ask you medical history questions — so we can make sure that the method you choose is safe for you. Right now, your medical history gives us no worry about risk with any of the methods.
Mia	Well, I'm glad I don't have to worry about my health. (<i>smiles</i>)
Kate	Often people ask me about what their partner might think about the method and also about protection from STDs and HIV.
Mia	I don't have a boyfriend right now, so I don't have to worry about what he thinks <u>or</u> about STDs. Anyway — I've used condoms in the past so I guess I'd just make sure I'd have them with me.
Kate	Good planning (<i>smiling</i>). What other questions do you have about the IUD?
Mia	How long does the IUD stay in your body?
Kate	The IUD that you were thinking about — the hormonal IUD — can last up to 5 years.
Mia	Oh, I don't know if I want something for that long. I might want to take it out sooner. And I might not like it.
Kate	You can have it taken out any time you want. Some women do decide to have the IUD removed before it expires. Sometimes it's because they want to get pregnant and other times it's because they don't like it. You can always change your mind about any of these methods on the chart except sterilization. The IUD can be removed at any time.
Mia	Oh that's good.
Kate	So Mia — We've talked about several of the methods on this chart. And you've had some great questions. What else do you want to know about any of these methods?



Mia	Well, this is a lot of information. I think I might want to get an IUD. But I'm not quite sure. Maybe I'll do some more thinking and make a decision before I go off to school in a couple of months.
Kate	That sounds like a plan to me. To help in your decision, I'll give you printed information about the IUD options we have in our clinic. It gives you instructions about how to make an appointment if you want to come in for an IUD placement. (hands her printed materials)
Mia	Thanks. This will help.
Kate	You said that you'd use condoms if you need them soon. How comfortable would you be asking a new partner to use condoms?
Mia	Well, fine I think. My old boyfriend and I used condoms every time we were together. It wasn't a problem. I told him from the beginning that I wasn't willing to take any chances on getting pregnant. I'd do the same thing with anyone.
Kate	So it sounds like you feel comfortable using condoms and also talking to a new partner about them. What would you do if the condom broke or came off?
Mia	I'm not sure. That never happened.
Kate	Okay — What have you heard about Emergency Contraception?
Mia	Oh yeah — my girlfriend was worried she might get pregnant after a condom broke. She came here and got emergency pills.
Kate	That's great. You know you can come here. You can also go to a local pharmacy for emergency contraception. The main thing to remember is that the sooner you use it, the more effective it is. In this clinic, we can give you a supply of emergency contraceptive pills today so that you have them on hand if you need them.
Mia	Thanks — that's good to know. I think I'll wait on that because there really isn't anyone in my life now. But if anything changes I'll come in and get them.
Kate	Okay, so let's talk about your plan for now: You want a method that's easy, private and really effective so you're going to think about an IUD before you go to college in the fall. You're going to read over the information about the different IUDs and call for an appointment when you decide. Does that sound right?



Mia	Yeah, that's right. I'm thinking that if I decide to get an IUD I should get it soon so I'll still be here in town and can come back and see you if I have any problems.
Kate	That sounds good. And you have the written instructions about how to make an appointment if you want to come in for an IUD or for any method you decide you want. In the meantime, if something changes and you do have sex, you have condoms.
Mia	Yes, that's right.
Kate	Just to make sure I explained clearly about taking Emergency Contraception, tell me what you remember.
Mia	Well, you said I should use it as soon as possible, so I would take it right away. If I already had some emergency pills, that would be no problem. Or I would go to a pharmacy.
Kate	That's right. And if you need them, we can give you condoms before you leave today.
Mia	No — I have some at home. I'm okay for now. But thanks... I'll see you again soon.
Kate	Ok Mia — Bye for now. I look forward to seeing you again. Call us anytime!



See Appendix C
for all other handouts
referenced in this activity.



Appendix A: References & Resources

Providing quality family planning services: recommendations of CDC and the U.S. Office of Population Affairs. MMWR. 2014 Apr; 63(RR04).

CDC. U.S. medical eligibility criteria for contraceptive use, 2010. MMWR. 2010 Jun; 59(RR04): 1-6.

Available from: http://www.cdc.gov/mmwr/preview/mmwrhtml/rr5904a1.htm?s_cid=rr5904a1_e

CDC. U.S. selected practice recommendations for contraceptive use, 2013. MMWR. 2013 Jun; 62 (RR05): 1-46.

Available from: <http://www.cdc.gov/reproductivehealth/unintendedpregnancy/usspr.htm>

Gavin L, Moskosky S. Developing new federal guidelines on family planning for the United States. Contraception. 2014 Sep; 90(3): 207-10.

Guttmacher Institute. Fact sheet: unintended pregnancy in the United States. New York: Guttmacher Institute; July 2015. Available from: <http://www.guttmacher.org/pubs/FB-Unintended-Pregnancy-US.html>

Module 1: Quality Counseling Principles

Providing quality family planning services: recommendations of CDC and the U.S. Office of Population Affairs, Appendix C. MMWR. 2014 Apr; 63(RR04): 45-6.

Dehlendorf C, Krajewski C, Borrero S. Contraceptive counseling: best practices to ensure quality communication and enable effective contraceptive use. Clin Obstet Gynecol. 2014 Dec; 57(4): 659-73.

Makoul G. Essential elements of communication in medical encounters: the Kalamazoo consensus statement. Acad Med. 2001 Apr; 76(4): 390-3.

Scholl I, Zill JM, Dirmaier J. An integrative model of patient-centeredness: a systematic review and concept analysis. PLoS ONE. 2014; 9(9): e107828.

Module 2: Client-Centered Communication Skills

The Four Habits Model. Oakland, CA; Kaiser Permanente, The Permanente Medical Group, Physician Education and Development; 2011. Available from: <http://ndep.nih.gov/media/The-Four-Habits-Model-508.pdf>

Joyce BL, Steenbergh T, Scher E. Use of the Kalamazoo Essential Elements Communication Checklist (adapted) in an institutional interpersonal and communication skills curriculum. J Grad Med Ed. 2010 Jun; 2(2):165-9.

Makoul G. Essential elements of communication in medical encounters: the Kalamazoo consensus statement. Acad Med. 2001 Apr; 76(4): 390-3.

Miller, WR and Rollnick S. Motivational interviewing: helping people change. 3rd ed. New York: Guilford Press; 2013.



Module 3: Quality Education Strategies

Providing quality family planning services: recommendations of CDC and the U.S. Office of Population Affairs, Appendix E. MMWR. 2014 Apr; 63(RR04): 48-50.

U.S. Food and Drug Administration. HPV, HIV, Birth Control. <http://www.fda.gov/birthcontrol>

Donnelly KZ, Foster TC, Thompson R. What matters most? The content and concordance of patients' and providers' information priorities for contraceptive decision making. *Contraception*. 2014 Sep; 90(3): 280-7.

National Quality Forum. Health literacy: a linchpin in achieving national goals for health and health-care. Washington, DC: National Quality Forum; 2009. Available from: http://www.qualityforum.org/Publications/2009/03/Health_Literacy_A_Linchpin_in_Achieving_National_Goals_for_Health_and_Healthcare.aspx

Russo JA, Miller E, Gold MG. Myths and misconceptions about long-acting reversible contraception (LARC). *J Adolesc Health*. 2013 Apr; 52(4 Suppl): S14-21.

Module 4: Interactive Client-Centered Decision Making

Borrero S, et al. "It just happens": a qualitative study exploring low-income women's perspectives on pregnancy intention and planning. *Contraception*. 2015; 91(2): 150-6.

Dehlendorf C, Bellanca H, Policar M. Performance measures for contraceptive care: what are we actually trying to measure? *Contraception*. 2015 Jun; 91(6): 433-7.

Dehlendorf C, Kimport K, Levy K, Steinauer J. A qualitative analysis of approaches to contraceptive counseling. *Perspect Sex Reprod Health*. 2014 Dec; 46(4): 233-40.

Dehlendorf C, Krajewski C, Borrero S. Contraceptive counseling: best practices to ensure quality communication and enable effective contraceptive use. *Clin Obstet Gynecol*. 2014 Dec; 57(4): 659-73.

Dehlendorf C, Levy K, Kelley A, Grumbach K, Steinauer J. Women's preferences for contraceptive counseling and decision making. *Contraception*. 2013 Aug; 88(2): 250-6.

Donnelly KZ, Foster TC, Thompson R. What matters most? The content and concordance of patients' and providers' information priorities for contraceptive decision making. *Contraception*. 2014 Sep; 90(3): 280-7.

Grady CD, Dehlendorf C, Cohen ED, Schwarz EB, Borrero S. Racial and ethnic differences in contraceptive use among women who desire no future children, 2006-2010 National Survey of Family Growth. *Contraception*. 2015 Jul; 92(1): 62-70.

Higgins J. Celebration meets caution: LARC's boons, potential busts, and the benefits of a reproductive justice approach. *Contraception*. 2014; 89: 237-41.

Jaccard J. Careful, current, and consistent: tips to improve contraceptive use. Washington, DC: National Campaign to Prevent Teen and Unplanned Pregnancy; 2010.

Jaccard J and Levitz N. Counseling adolescents about contraception: towards the development of an evidence-based protocol for contraceptive counselors. *J Adolesc Health*. 2013 Apr; 52(4 Suppl): S6-13.



Module 5: Confirming Understanding and Making a Plan

Kutner M, Greenberg E, Jin Y, et al. The health literacy of America's adults: results from the 2003 National Assessment of Adult Literacy. Washington, DC: US Department of Education; 2006.

Schillinger D, Piette J, Grumbach K, et al. Closing the loop: physician communication with diabetic patients who have low health literacy. *Arch Intern Med.* 2003; 163: 83–90.

The teach back technique: communicating effectively with patients. Kenilworth, NJ: Merck & Co, Inc.; 2011. Available from: http://www.care1st.com/az/PDF/provider/compliance/cultural_competency/MERCK_TeachBackTechnique.pdf

Other Resources

Information on condoms:

CDC. Condom Fact Sheet in Brief. Available from: <http://www.cdc.gov/condomeffectiveness/brief.html>

Information on abstinence, fertility awareness methods, spermicides, withdrawal:

Contraceptive Technology. Available from: <http://www.contraceptivetechnology.org/>

Information on Lactational Amenorrhea Method (LAM):

Lactational amenorrhea method: a reference guide for services providers. http://irh.org/wp-content/uploads/2013/04/LAM_ReferenceGuide_JAN10.pdf

Family Planning National Training Centers. www.fpntc.org

Cardea Resource Center: www.cardeaservices.org/resourcecenter

Kaufman D. ABC of learning and teaching in medicine: applying educational theory in practice. *BMJ.* 2003 Jan; 326(7382): 213-6.

Taylor, DC, Hamdy H. Adult learning theories: implications for learning and teaching in medical education: AMEE Guide No. 83. *Med Teach.* 2013 Nov; 35(11): e1561-72.



Appendix B: List of Printed Materials

See below for a list of printed materials for each activity in the Toolkit for Training Staff.

Please note: many activities also require additional non-printed materials (3 x 5 notecards, large paper, markers, etc.). Please review the first page of each activity for a complete list of materials.

Module 1: Quality Counseling Principles

Activity #	Activity Name	Printed Handouts, Worksheets, Job Aids	Used in Other Activities?
1.1	What is Client Centered Counseling?	<i>None</i>	
1.2	My Professional Role vs. My Personal Values	Exploring Our Personal Values worksheet Being Client-Centered — A Self-Assessment	
1.3	Principles for Providing Quality Counseling	Contraceptive Counseling Process Guide Principles for Providing Quality Counseling <i>Optional:</i> handouts of 1.3 presentation slides	2.1, 4.2, 5.2 2.1

Module 2: Client-Centered Communication Skills

Activity #	Activity Name	Printed Handouts, Worksheets, Job Aids	Used in Other Activities?
2.1	How to Establish Rapport	Contraceptive Counseling Process Guide <i>Optional:</i> Principles for Providing Quality Counseling	1.3, 4.2, 5.2 1.3
2.2	The OARS Model — Essential Communication Skills	OARS Model: Essential Communication Skills OARS Cards job aid OARS Practice Worksheet <i>Optional:</i> handouts of 2.2 presentation slides	2.3 2.3
2.3	Communicating with Brilliance — Practicing Your Skills	OARS Model: Essential Communication Skills OARS Cards job aid OARS Observer Checklist OARS Practice Instructions	2.2 2.2



Module 3: Quality Education Strategies

Activity #	Activity Name	Printed Handouts, Worksheets, Job Aids	Used in Other Activities?
3.1	Birth Control Information — Simple and Accurate	Birth Control Method Options chart Explaining Contraception Job Aids Birth Control Information — Simple, Accurate and Complete worksheet <i>Recommended:</i> Male and female anatomy charts <i>Optional:</i> Menstrual cycle chart	All Module 3, 4.4, 5.2 All Module 3, 5.1 3.2, 3.3 3.2
3.2	Explaining Characteristics and Effective Use of a Method	Birth Control Method Options chart Explaining Contraception Job Aids Characteristics and Effective Use Practice Instructions <i>Recommended:</i> Male and female anatomy charts <i>Optional:</i> Menstrual cycle chart	All Module 3, 4.4, 5.2 All Module 3, 5.1 3.1, 3.3 3.1
3.3	Birth Control — Myth Busting!	Birth Control Method Options chart Explaining Contraception Job Aids Myths and Misinformation Cards <i>Recommended:</i> Male and female anatomy charts	All Module 3, 4.4, 5.2 All Module 3, 5.1 3.1, 3.2
3.4	What are the Seven Strategies for Effective Education?	Birth Control Method Options chart Explaining Contraception Job Aids Seven Strategies for Effective Education	All Module 3, 4.4, 5.2 All Module 3, 5.1 3.5
3.5	Applying the Seven Strategies to Contraceptive Education	Birth Control Method Options chart Explaining Contraception Job Aids (<i>selected methods</i>) Seven Strategies for Effective Education Seven Strategies Observation Checklist Role Play Scenarios 1, 2, and 3	All Module 3, 4.4, 5.2 All Module 3, 5.1 3.4



Module 4: Interactive Client-Centered Decision Making

Activity #	Activity Name	Printed Handouts, Worksheets, Job Aids	Used in Other Activities?
4.1	A "Perfect" Birth Control Method?	<i>None</i>	
4.2	Factors that Influence Contraceptive Decision Making	How Do I Choose? Contraceptive Counseling Process Guide <i>Optional:</i> handouts of 4.2 presentation slides	4.3, 4.4 1.3, 2.1, 5.2
4.3	Personalized and Interactive Client Assessment	How Do I Choose? OARS Model: Essential Communication Skills <i>Optional:</i> Conducting a Sexual Health Assessment <i>Optional:</i> handouts of 4.3 presentation slides	4.2, 4.4 2.2, 2.3
4.4	Client-Centered Decision Making	How Do I Choose? Birth Control Method Options Chart Interactive Contraceptive Counseling and Education Client Centered Decision Making Observation Checklist Role Play Scenarios 1, 2, and 3	4.2, 4.3 All Module 3, 5.2

Module 5: Confirming Understanding and Making a Plan

Activity #	Activity Name	Printed Handouts, Worksheets, Job Aids	Used in Other Activities?
5.1	Using the Teach-Back Method and Closing a Session	Explaining Contraception Job Aids (<i>selected methods</i>) Role Play Scenarios 1 and 2 Teach Back Sample Script <i>Optional:</i> handouts of 5.1 presentation slides	All Module 3
5.2	Contraceptive Counseling and Education in Review	Contraceptive Counseling Process Guide Case Study Script Birth Control Method Options chart (<i>1 copy only</i>)	1.3, 2.1, 4.2 All Module 3, 4.4

For all toolkit activities, we recommend you print at least one copy of the following for your reference:

- Providing Quality Family Planning Services (QFP), Recommendations of CDC and OPA, **Appendix C**
- Providing Quality Family Planning Services (QFP), Recommendations of CDC and OPA, **Appendix E**
- Any agency policies or procedures that will support the client-centered, culturally inclusive services provided in your clinic setting



Appendix C: Quality Counseling Handouts

The following handouts are included in the Toolkit for Training Staff and may be particularly helpful references for all staff to review, either as an introduction to key quality contraceptive counseling skills and strategies, or as a follow-up reference to reinforce training activities.

- **Principles for Providing Quality Counseling**
- **Contraceptive Counseling Process Guide**
- **OARS Model: Essential Communication Skills**
- **Birth Control Method Options Chart**
- **Explaining Contraception Job Aids**
- **Seven Strategies for Effective Education**
- **How Do I Choose?**
- **Conducting a Sexual Health Assessment**
- **Interactive Contraceptive Counseling and Education**

Principles for Providing Quality Counseling

Counseling is a process that enables your client to make and follow through on decisions. *Education* is an integral component of the counseling process that helps clients make informed decisions. Providing quality counseling is an essential component of client-centered care.

Your client is the primary focus when providing counseling related to reproductive and sexual health decision making about preventing or achieving pregnancy and supporting healthy behaviors. Using **client-centered** skills, you tailor the interactive counseling and educational encounter to meet the unique and culturally appropriate needs of your client.

PRINCIPLE 1:

Establish and maintain rapport with the client

- ▶ Create a welcoming environment — greet the client warmly, show you care. Listen to and engage your client by asking open-ended questions. Explain privacy and confidentiality to help build a climate of safety and trust that will encourage questions at every stage of the client encounter.



PRINCIPLE 2:

Assess the client's needs and personalize discussions accordingly

- ▶ Tailor your questions and conversation so that your client's clinical needs, personal life considerations and psychological concerns are integrated into important education and decision making discussion.



PRINCIPLE 3:

Work with the client interactively to establish a plan

- ▶ Address your client's personal goals by interactively exploring decision making and readiness for behavior change if needed. Help establish a plan that will allow the client to achieve personal goals.

PRINCIPLE 4:

Provide information that can be understood and retained by the client

- ▶ Provide an opportunity for your client to learn medically accurate information that is balanced, nonjudgmental and in accordance with your client's plan at this time in her or his life.

PRINCIPLE 5:

Confirm client understanding

- ▶ Use an interactive teach-back process to give your client an opportunity to say — in his or her own words — the important information shared during the encounter. The goal of using a teach-back approach is to clarify any client misunderstandings to ensure your client's success in their reproductive health choices.



Source: Providing Quality Family Planning Services: Recommendations of CDC and the U. S. Office of Population Affairs, 2014; Appendix C



Quality Family Planning
www.fpntc.org

FPNTC is supported by the Office of Population Affairs of the U.S. Department of Health and Human Services. The information presented does not necessarily represent the views of OPA, DHHS, or FPNTC member organizations.

November 2015

Contraceptive Counseling Process Guide

Process

Beginning (and throughout)

Establish and maintain rapport with the client

- ▶ Warmly greet the client by name and introduce yourself
- ▶ Be genuine, showing respect and empathy
- ▶ Ask about the client's reason(s) for today's visit, plan and prioritize visit
- ▶ Explain private and confidential services
- ▶ Ask open-ended questions
- ▶ Respectfully affirm what you see and hear (showing interest, support and cultural awareness)
- ▶ Show that you care by listening (verbally and non-verbally)
- ▶ Reflect on what you observe and hear, to gain a deeper understanding
- ▶ Summarize key points throughout with a focus on the client's goals
- ▶ If using EMR, position the monitor to keep eye contact

Middle

Assess the client's needs and personalize discussions accordingly

- ▶ Review and update the medical, sexual and social history
- ▶ Explore client preferences regarding method characteristics: frequency of use, effectiveness, how to use, menstrual changes, side effects, and benefits
- ▶ Ask about client knowledge and experience with birth control methods
- ▶ Address pregnancy and parenting intention/ambivalence along with STD/HIV protection
- ▶ Respectfully explore client beliefs and feelings, including ethnic, cultural, and/or individual factors that may be relevant to their birth control method decisions and method use

Work with the client interactively to establish a birth control method plan

- ▶ Ask open-ended questions about concerns or possible barriers relevant to method choice
- ▶ Explore the client's method preferences, and if appropriate, offer additional information about the most effective methods
- ▶ Help the client to optimize method choice by assisting the client in aligning their preferences with their method selection
- ▶ Reflect back important thoughts or feelings you hear from the client and/or feelings you sense from the discussion
- ▶ Clarify partner involvement and the role of others who may be important to the client's decision making and method use
- ▶ Affirm and support the decision making process with a respectful, nonjudgmental approach in helping the client make a plan

Provide information that can be understood and retained by the client

- ▶ Provide balanced, unbiased, tailored information about method characteristics in an interactive conversation
- ▶ Provide accurate information (correct use, effectiveness, benefits, side effects, potential risks, STD/HIV protection)
- ▶ Use clear, understandable words, images, materials, models and/or sample methods
- ▶ Use numbers and comparisons that are easy to understand
- ▶ Assess and address myths and misinformation in a respectful and affirming way
- ▶ Include information about STD protection and emergency contraception

Closing

Confirm client understanding

- ▶ Ask the client to tell and show what was learned (teach-back) and provide additional information, as needed
- ▶ Address any possible barriers to a successful plan and method use
- ▶ Confirm the client's plan for correct method use and follow-up, including what to do if dissatisfied with the method, back-up method, and emergency contraception, as needed
- ▶ Provide contact information and future opportunities for follow up, other methods or services
- ▶ Summarize with key points and provide a friendly close



Quality Family Planning
www.fpntc.org

OARS Model: Essential Communication Skills

OARS is a skills-based, client-centered model of interactive techniques. These skills include verbal and non-verbal responses and behaviors that need to be culturally sensitive and appropriate. This model integrates the five principles of providing quality counseling from the QFP recommendations. Using these skills will help establish and maintain rapport with your client, assess your client's needs, and personalize your counseling and education responses.

O

OPEN-ENDED QUESTIONS

- ▶ Establish a safe environment and help to build rapport and a trusting and respectful professional relationship.
- ▶ Explore, clarify and gain an understanding of your client's world.
- ▶ Learn about your client's experiences, thoughts, feelings, beliefs, and hopes for the future.

You may ask:

- ✓ *What... brings you to the clinic today?*
- ✓ *When... if ever, might you want to be a parent?*
- ✓ *Where... will you get the support you need?*
- ✓ *Who... have you talked to about birth control?*
- ✓ *How... have you made decisions before about birth control?*
- ✓ *Tell me more about...?*

A

AFFIRMING

- ▶ Build rapport, demonstrate empathy, and affirm your client's strengths and abilities.
- ▶ Build on your client's level of self-efficacy and share a belief that they can be responsible for their own decisions and life choices.

You may ask:

- ✓ *It's great that you are here today. It's not always easy...*
- ✓ *It sounds like you've been really thoughtful about your decision.*
- ✓ *You're really trying hard to...*
- ✓ *It seems like you are really good at...*

Source: Miller, W.R., Rollnick, S., *Motivational Interviewing: Helping People Change*, 3rd Edition. New York: The Guilford Press, 2013.



Quality Family Planning
www.fpntc.org

FPNTC is supported by the Office of Population Affairs of the U.S. Department of Health and Human Services. The information presented does not necessarily represent the views of OPA, DHHS, or FPNTC member organizations.

OARS Model: Essential Communication Skills

R

REFLECTIVE LISTENING

- ▶ Listen to your client to help you gain a deeper understanding of their life.
- ▶ Listen, observe, and share (reflect on) your own perceptions of what your client shares.
- ▶ Reflect on the words that they use — *You say you really don't want to be pregnant right now.*
- ▶ Reflect on behavior and feelings — *You have tears in your eyes and you sound sad...*
- ▶ Your client gains an opportunity to “hear” your experience of what was shared reflected back to them.

You can reflect words, emotions, and/or behaviors:

(Reflecting words) *Some of what I heard you say...*

(Reflecting emotions) *You seem [to be feeling]...*

- ✓ *sad*
- ✓ *frustrated*
- ✓ *excited*
- ✓ *angry*

(Reflecting behavior) *I noticed...*

- ✓ *tears in your eyes...*
 - ✓ *your voice sounds shaky...*
 - ✓ *you smiled when you said that...*
-

S

SUMMARIZING

- ▶ Help move the conversation from the beginning, through the middle, to closing.
- ▶ Check that you are understanding your client's goals and preferences.
- ▶ Confirm that your client has an understanding of the key elements of a plan.

Summarizing can be demonstrated in three ways:

- ✓ A collective summary — *So let's go over what we have talked about so far.*
 - ✓ A linking summary — *A minute ago you said you wanted to talk to your partner... Would you like to talk more about how you might try?*
 - ✓ A transitional summary to close — *So you've just described your plan. We're always here to help in any way. What other questions do you have before you leave today?*
-



Quality Family Planning
www.fpntc.org

Birth Control Method Options

Most Effective

Least Effective

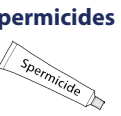
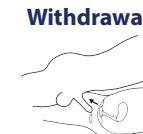
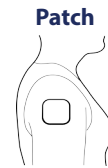
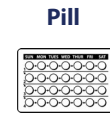
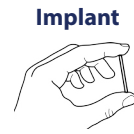

	Female Sterilization	Male Sterilization	IUD	Implant	Injectables	Pill	Patch	Ring	Diaphragm	Male Condom	Female Condom	Withdrawal	Sponge	Fertility Awareness Based Methods	Spermicides
Risk of pregnancy*	.5 out of 100	.15 out of 100	LNG: .2 out of 100 CopperT: .8 out of 100	.05 out of 100	6 out of 100	9 out of 100			12 out of 100	18 out of 100	21 out of 100	22 out of 100	12–24 out of 100	24 out of 100	28 out of 100
How the method is used	Surgical procedure		Placement inside uterus	Placement into upper arm	Shot in arm, hip or under the skin	Take a pill	Put a patch on skin	Put a ring in vagina	Use with spermicide and put in vagina	Put over penis	Put inside vagina	Pull penis out of the vagina before ejaculation	Put inside vagina	Monitor fertility signs. Abstain or use condoms on fertile days.	Put inside vagina
How often the method is used	Permanent		Lasts up to 3–12 years	Lasts up to 3 years	Every 3 months	Every day at the same time	Each week	Each month	Every time you have sex					Daily	Every time you have sex
Menstrual side effects	None		LNG: Spotting, lighter or no periods CopperT: Heavier periods	Spotting, lighter or no periods	Spotting, lighter or no periods	Can cause spotting for the first few months. Periods may become lighter.			None						
Other possible side effects to discuss	Pain, bleeding, infection		Some pain with placement		May cause appetite increase/weight gain	May have nausea and breast tenderness for the first few months.			Allergic reaction, irritation			None	Allergic reaction, irritation	None	Allergic reaction, irritation
Other considerations	Provides permanent protection against an unintended pregnancy.		LNG: No estrogen. May reduce cramps. CopperT: No hormones. May cause more cramps.	No estrogen	No estrogen. May reduce menstrual cramps.	Some client's may report improvement in acne. May reduce menstrual cramps and anemia. Lowers risk of ovarian and uterine cancer.			No hormones	No hormones. No prescription necessary.		No hormones. Nothing to buy.	No hormones. No prescription necessary.	No hormones. Can increase awareness and understanding of a woman's fertility signs.	No hormones. No prescription necessary.

Counsel all clients about the use of condoms to reduce the risk of STDs, including HIV infection.

*The number of women out of every 100 who have an unintended pregnancy within the first year of typical use of each method.

Other Methods of Birth Control: (1) Lactational Amenorrhea Method (LAM) is a highly effective, temporary method of contraception; and (2) Emergency Contraception: emergency contraceptive pills or a copper IUD after unprotected intercourse substantially reduces risk of pregnancy. Reference for effectiveness rates: Trussell J. Contraceptive failure in the United States. Contraception 2011; 83: 397-404. Other references available on www.fpntc.org.

Female Sterilization

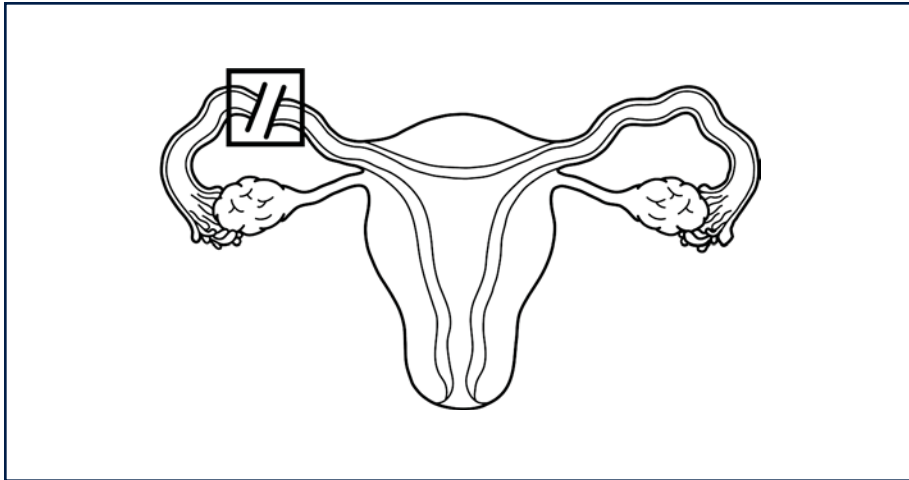

Note: Female sterilization is also frequently referred to as **tubal ligation** or **tubal sterilization**.

How female sterilization works

- Female sterilization, or tubal ligation, is often called “having your tubes tied.” It’s a procedure that permanently blocks the fallopian tubes so the egg cannot move to the uterus and the sperm cannot reach the egg.
- Sterilization is considered a permanent (not reversible) method of birth control and should be chosen only when people are sure that they do not want children in the future.
- Tubal sterilization does not remove any organs; it only affects the fallopian tubes.
- There are no changes in the production of female hormones or periods after a tubal sterilization.
- There should be no changes in sexual desire, sexual response or orgasm.

How female sterilization is done

Two female sterilization (or tubal ligation) procedures are available.

- The first procedure is an operation that can be done in a clinic or hospital with either a local (awake) or general anesthetic (asleep). It takes about 30 minutes to do the procedure. A very small cut (incision) is made either beside the belly button or lower on the abdomen. Thin instruments are put through the incision to cut, block, or tie off the fallopian tubes. Because of the tiny incision and the short time of surgery, it is usually possible to go home the same day.
 - There may be slight pain or soreness in the abdomen for 2-3 days, or a sore throat or headache from the anesthesia.
 - Most people have no other problems and feel back to normal within a week.
 - It is fine to have sex as long as it doesn’t cause discomfort.
 - A tubal ligation can be done immediately after childbirth or at any time during the menstrual cycle.
- The second procedure, transcervical sterilization (or Essure®) is conducted by a trained provider in a clinical/office setting. The provider places a soft, flexible device into each fallopian tube to prevent the joining of sperm and an egg (fertilization). This device is placed in the tubes after being passed through the vagina, cervix and uterus using a small scope. There have been some cases in which the device caused persistent pain or allergic reactions. In other cases it has perforated the uterus or tubes and travelled into the abdominal cavity, needing to be removed surgically. The average procedure time is also about 30 minutes and a local anesthesia and/or intravenous sedation are recommended.
 - After the device is inserted, it is important to use contraception until having a procedure, three months later, to be sure the tubes are completely blocked. This procedure is painful for some people.

Effectiveness (Risk of pregnancy)

- Tubal sterilization is a highly effective, permanent method of birth control.
- Fewer than 1 woman out of 100 (*in fact only 5 women out of 1,000*) will become pregnant after tubal ligation in the first year after the procedure.

Possible side effects

- Surgery can be associated with discomfort at the surgical site and the need for a recovery period after anesthesia.

Other considerations for female sterilization

- Tubal sterilization surgery gives excellent permanent protection from pregnancy.
- It is safe and private; a partner's involvement is not required for sterilization.
- Tubal sterilization is considered permanent and irreversible. Even though it's possible with advanced surgery to reconnect the tubes, there is no guarantee this will result in a future pregnancy. Reconnection surgery can be very expensive and may not be covered by public or private insurance.
- Tubal sterilization should include counseling by a qualified healthcare provider prior to the surgery, addressing potential risks, side effects, and the procedure process. This conversation should include a discussion about the possibility of regretting the decision to have a sterilization.
- Tubal sterilization is expensive if insurance or financial support is not available. Medicaid and other state funds may pay for tubal sterilization.
- If the tubal sterilization surgery is paid for by federal or state funds, a 30-day waiting period is required.

Issues to explore with clients

- Whether vasectomy for a partner may be an option
- Whether the client would like to consider a highly effective, reversible method as an alternative
 - Some people regret having had a sterilization procedure, especially if they are very young, have no children at the time of sterilization, or are in an unstable relationship. Healthcare providers can support clients who are considering their options in the context of possible regret, leaving the final decision to have sterilization in the hands of the client.

Key reminders for clients

If at any time you want to talk about other birth control methods, please come back to see us.

Remind all of your clients about the use of condoms to help reduce the risk of sexually transmitted disease (STDs), including HIV infection.

Reference for effectiveness rates: Trussell J. Contraceptive failure in the United States. *Contraception* 2011; 83: 397-404.

Male Sterilization

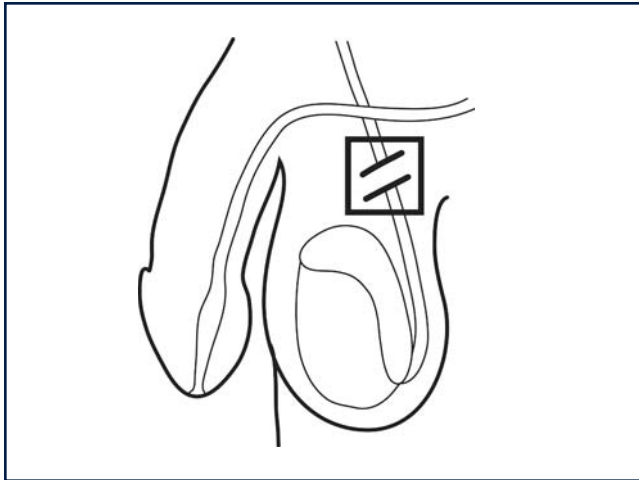

Note: Male sterilization is also frequently referred to as vasectomy.

How a vasectomy works

- Male sterilization, or vasectomy, is a simple surgery in which the tubes (vas deferens) that carry sperm up to the penis are cut and sealed.
- Vasectomy is considered a permanent (not reversible) method of birth control and should be chosen only by individuals who are sure that they do not want children in the future.
- After a vasectomy, male hormones and sperm will still be produced, but the sperm will not be able to join with the other fluids in the semen.
- When sperm cells aren't used, the body will absorb them.
- The amount of fluid in the ejaculation is the same, except there are no sperm. Sex drive, ability to have sex and orgasms do not change because of a vasectomy.

How a vasectomy is done

Two vasectomy procedures are available in a clinic or doctor's office and each take about 30 minutes.

- For each procedure, a local anesthetic (like dentists use) is injected into the skin of the sack that holds the testicles.
- A *no scalpel vasectomy* (NSV) — is done by making a small puncture in the testicles through which the tubes (vas deferens) are sealed. This procedure is shorter, generally has fewer side effects, and is less painful than the traditional method.
- The *traditional* method of vasectomy involves, a small cut made in the testicles. The tubes are pulled through the opening and sealed. The incision is then closed.
- Since sperm may still be in the tubes, vasectomy is not effective until a semen analysis has been performed after the procedure. The provider performing the vasectomy will give instructions about a follow up visit to check the semen to make sure no sperm are present.

Effectiveness (Risk of pregnancy)

- A vasectomy is a highly effective, permanent method of birth control.
- *Fewer than 1 woman in 100* will become pregnant in the first year after her partner has the procedure.
- A pregnancy happens very rarely, when the tubes were not completely sealed during surgery or if the tubes grow back together.
- A pregnancy may also happen if a couple does not use some other kind of birth control until the follow-up semen test shows that there are no sperm in the ejaculation fluid.

Possible side effects

- Bleeding under the skin after the procedure.
- Swelling, bruising and discomfort that can be reduced with mild pain medication.
- Most side effects after vasectomy go away within one or two weeks.
- It is recommended to avoid heavy physical labor for at least 48 hours.
- An athletic supporter and ice packs can be used to make this healing time more comfortable.
- Sex can be resumed when the cut is healed and the area is no longer sore.

Other considerations for vasectomy

- Sterilization is one of the safest, most effective and most cost effective contraceptive methods.
- Vasectomy is safer, simpler, and less expensive than tubal ligation.
- It is a very private method, with no need for partner involvement.
- Research continues to show that the chances of getting heart disease, cancer, or other illnesses do not increase after a vasectomy.
- A vasectomy can be expensive if insurance or financial support is not available. Public funds may be available to pay for the surgery.

A vasectomy is considered permanent and irreversible. Even though it is possible with advanced surgery to reconnect the tubes, there is no guarantee this will result in a future pregnancy. Reconnection surgery is very expensive and may not be covered by public or private insurance. If the vasectomy is paid for by federal or state funds, a 30-day waiting period is required.

Issues to explore with clients

- Whether they can talk to their partner about the possibility of having a vasectomy
- Whether the couple would like to consider a highly effective, reversible method
 - Some people regret having had a sterilization procedure, especially if they are very young, have no children at the time of sterilization, or are in an unstable relationship. Healthcare providers can support clients who are considering their options in the context of possible regret, leaving the final decision to have sterilization in the hands of the client.
- The potential need to use a different method of contraception if having sex with other partners.

Key reminders for clients

If at any time you want to talk about other birth control methods, please come back to see us.

Remind all of your clients about the use of condoms to help reduce the risk of sexually transmitted disease (STDs), including HIV infection.

Reference for effectiveness rates: Trussell J. Contraceptive failure in the United States. *Contraception* 2011; 83: 397-404.

Intrauterine Device (IUD)

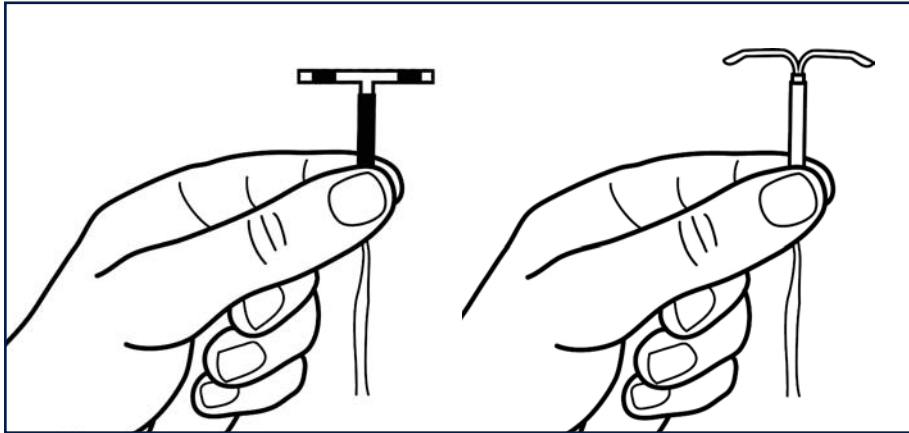

Two types of intrauterine contraceptives are available in the United States.

- A small plastic T-shaped device wrapped with copper (Cu-IUD, or Paragard®)
- A small T-shaped device that continually releases a low dose progestin hormone (levonorgestrel) into the uterus (LNG-IUD). There are several brands of hormonal IUDs, including Skyla®, Mirena®, Kyleena®, and Liletta®.

How an IUD works

- Both types of IUDs are placed inside the uterus by a trained healthcare provider.
- Both the Cu-IUD and the LNG-IUD primarily work by affecting the way sperm move and stop sperm from getting to the egg.
- The LNG-IUD also works by thickening the cervical fluid — the liquid at the opening of the uterus — to stop sperm from getting in the uterus.
- The LNG-IUD also prevents ovulation in some users in some menstrual cycles.
- These devices do not interrupt an implanted pregnancy.

How to use an IUD

- An IUD can be inserted at any time during the menstrual cycle, or inserted immediately after abortion or childbirth, even if breastfeeding.
- Placement of an IUD is a minor, non-surgical procedure done through the cervix.
- After insertion, an exam with a healthcare provider is advised if the person experiences symptoms of pregnancy or thinks their IUD might have come out. An exam is also usually done if the person with the IUD feels hard plastic in their vagina — or if their partner feels it.
- The IUD can be removed at any time; it is not required that the device be used for the full length of time for which it is approved.

Effectiveness (Risk of pregnancy)

- With typical use, *fewer than 1 woman in 100* become pregnant in the first year of use.
- Cu-IUD is effective up to 10 years. The LNG-IUD is effective up to 3-5 years (depending on which one is selected). The healthcare provider can consider and discuss new research that shows some IUDs may be effective for even longer time periods.

The copper IUD is also a highly effective method of emergency contraception (EC) for those women who would like to use an IUD as ongoing contraception. For EC, the IUD must be inserted within 5 days of the first act of unprotected sexual intercourse.

Possible side effects

- Menstrual changes

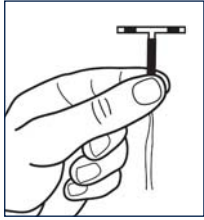
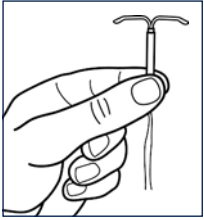
Copper IUD	Hormonal IUD
	
May cause longer, heavier menstrual periods (bleeding). Spotting may happen between periods. Menstrual cramping may increase.	May cause lighter menstrual periods or no periods at all. Spotting may happen between periods. Menstrual cramping may be reduced.

- Other possible side effects
 - There may be some pain or discomfort with the IUD placement.
 - Rarely, if a person has a sexually transmitted infection at the time of insertion, the insertion process can introduce infection from the vagina into the uterus, and increase the risk of pelvic inflammatory disease (PID).

Other considerations for an IUD

- IUDs are safe and available for adolescents and people who have never been pregnant.
- IUDs have no estrogen, and therefore use is not limited among people with conditions such as migraine.
- The LNG-IUD decreases the risk of uterine cancer.
- The Cu-IUD is very effective as emergency contraception if inserted within 5 days of unprotected sexual intercourse.
- Rarely, a pregnancy can happen. If pregnancy happens, the IUD should be removed if the strings are visible.

- Expulsion of the IUD can occur.
- LNG-IUDs can decrease symptoms of heavy menstrual bleeding or menstrual cramping, and can also help with anemia.
- The client's healthcare provider can talk about potential risks, side effects, and the insertion and removal process for these devices.

Issues to explore with clients

- The importance of using a highly effective method
- Feelings around having an IUD in their uterus
- Preferences about bleeding, including feelings about not having bleeding (LNG-IUD) or having unpredictable (LNG-IUD) or heavy bleeding (Cu-IUD)
- Feelings about using a method that requires a provider to insert and remove it.

Key reminders for clients

If at any time you are dissatisfied with your method, or you want to change methods, or have an IUD removed, please come back to see us.

Remind all of your clients about the use of condoms to help reduce the risk of sexually transmitted disease (STDs), including HIV infection.

Reference for effectiveness rates: Sundaram A. Contraceptive failure in the United States. *Perspect Sex Reprod Health* 2017;49:7-16.

Implant

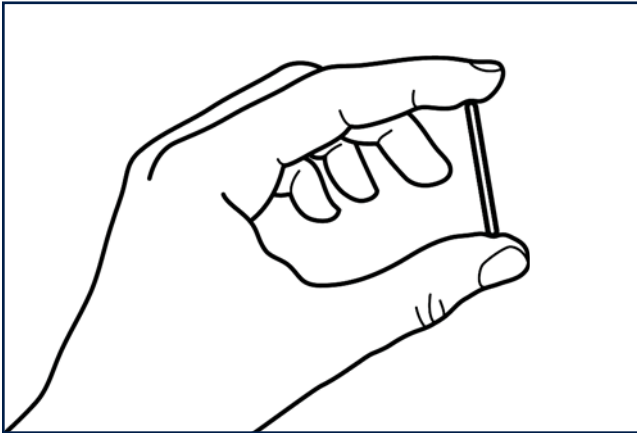

How an implant works

- An implant is a small, flexible capsule or rod that is placed under the skin of the upper, inner arm.
- An implant is filled with a low dose progestin hormone that is continually released into the body. The progestin in the implant lowers the chance that the body will release an egg so that no egg is present to be fertilized.
- The implant also works by thickening the cervical fluid — the liquid at the opening of the uterus — to stop sperm from getting into the uterus.

How to use an implant

- The implant can be placed immediately after childbirth if desired, even if breastfeeding.
- The implant is placed into the upper arm through a special needle by a trained healthcare provider using local anesthesia. The healthcare provider will give follow up instructions.
- The implant works for up to three years. The healthcare provider can consider and discuss new research that shows the implant may be effective for a longer time period.
- An implant can be removed at any time; it is not required that the implant be used for the full three years.
- Removal of an implant requires a minor surgical procedure that typically takes only a few minutes using local anesthesia.

Effectiveness (Risk of pregnancy)

- With typical use, fewer than 1 woman in 100 will become pregnant in the first year of use.
- The implant is effective up to 3 years.

Possible side effects

- Menstrual changes
 - Irregular and unpredictable bleeding
 - Bleeding can be heavy or light, last for a few days or many days, or there may be no bleeding at all for several weeks
 - Periods may stop completely
 - Bleeding patterns can change over time
 - Menstrual cramping may be reduced

- Other possible side effects
 - There may be some discomfort and bruising at the place of insertion for a short time
 - Some people have a small scar after removal

Other considerations for an implant

- The implant is safe with very few complications.
- It has no estrogen, and therefore its use is not limited among people with conditions such as migraine.
- The implant generally decreases menstrual bleeding, and it can reduce the risk of anemia.
- The client's healthcare provider can talk about managing potential risks, side effects and the placement and removal procedures for the implant.

Issues to explore with clients

- Importance of using a highly effective method
- Feelings around having an implant in their arm
- Preferences about bleeding, including feelings about having unpredictable bleeding
- Feelings about using a method that requires a provider to remove it

Key reminders for clients

If at any time you are dissatisfied with your method, or you want to change methods, or have your implant removed, please come back to see us.

Remind all of your clients about the use of condoms to help reduce the risk of sexually transmitted disease (STDs), including HIV infection.

Reference for effectiveness rates: Sundaram A. Contraceptive failure in the United States. *Perspect Sex Reprod Health* 2017; 49:7-16

Injectable (The Shot)

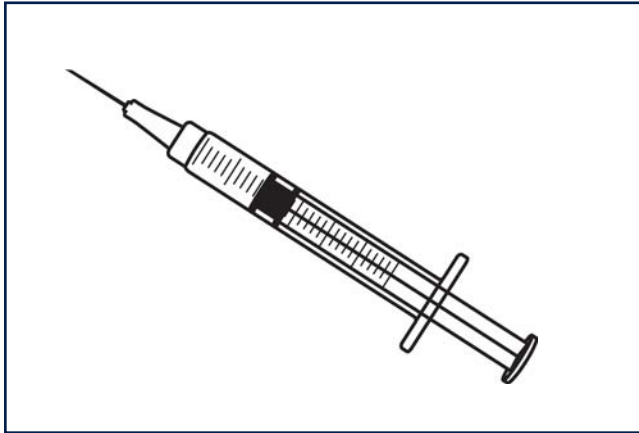

How the shot works

- The injectable method of contraception contains one hormone — a progestin. Often clients refer to this method as “the shot” or “depo” (Depo-Provera®).
- The progestin hormone in the shot stops the body from releasing an egg, so no egg can be fertilized.
- Progestin also works by thickening the cervical fluid (liquid at the opening of the uterus) which can stop sperm from getting into the uterus.

How to use the shot

- The shot is given by a qualified healthcare provider; it requires a prescription.
- The shot is given in the arm, hip, or under the skin every 3 months (12-15 weeks).
- The shot may be given immediately after childbirth and is safe to use when breastfeeding.

Effectiveness (Risk of pregnancy)

- The effectiveness of the shot depends on getting the shot on time.
- With typical use, *4 women out of 100* will become pregnant in the first year of use.
- The chance of pregnancy increases if the person waits more than 3 months between shots.

Possible side effects

- Menstrual changes
Bleeding patterns with the shot vary and may include:
 - Irregular spotting or bleeding
 - Heavier periods
 - Lighter periods
 - No periods (which becomes more common over time)
- Other possible side effects
 - Decrease in cramps
 - Increased appetite and weight gain
 - Mood changes

Other considerations for the shot

- It has no estrogen, and therefore its use is not limited among people with conditions such as migraine.
- The shot may delay return to fertility.
- Using the shot lowers the risk of uterine cancer and can also help with anemia.
- Using the shot can make existing depression worse. People who have severe depression should talk to a healthcare provider about using this method.
- The Federal Drug Administration (FDA) placed a warning on the shot because of concerns about decreased bone density in those using this method for more than two years. However, studies indicate that there are no long-term effects on bone health from using the shot.
- The client's healthcare provider can talk more about using the shot and can answer questions about bone loss as well as managing possible side effects.

Issues to explore with clients

- The ease and acceptability of coming back to the clinic every three months
- The acceptability of having injections
- Feelings about irregular bleeding
- Concerns about weight gain and depression

Key reminders for clients

For the shot to be highly effective, you will need to get your next shot in the next 3 months. How easy will it be for you to come back to the clinic for your next shot? What might you do if you can't get back to the clinic?

If at any time you are dissatisfied with your method, or you want to change methods, please come back to see us.

If you can't get back to the clinic on time and you have unprotected sex, you can use emergency contraception (EC) to prevent pregnancy. To find out where you can get EC, ask your pharmacist, call your local family planning clinic, or visit the website <http://ec.princeton.edu/emergency-contraception.html>

Remind all of your clients about the use of condoms to help reduce the risk of sexually transmitted disease (STDs), including HIV infection.

Reference for effectiveness rates: Sundaram A. Contraceptive failure in the United States. *Perspect Sex Reprod Health* 2017;49:7-16.

Pills

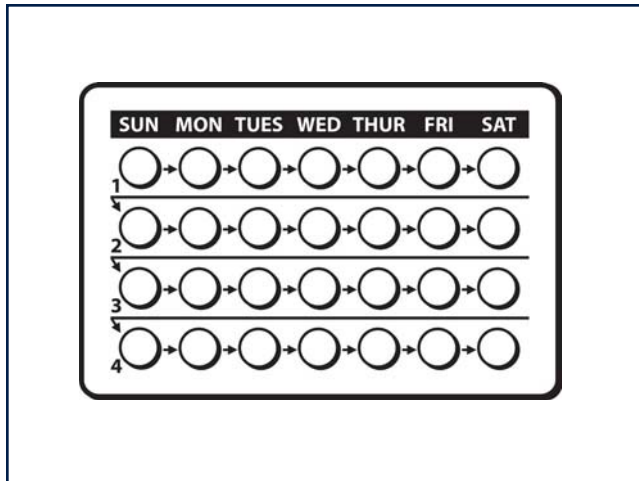

How pills work

- Combination birth control pills contain hormones (estrogen and progestin) that are similar to hormones that are produced naturally by the body.
- The hormones in the pill work by stopping the body from releasing an egg, so no egg can be fertilized.
- The hormones in the pill also work by thickening the cervical fluid (liquid at the opening of the uterus) which can stop sperm from getting into the uterus.

How to use the pills

- In most states, the pills require a prescription from a qualified healthcare provider. In some states, consultation with a pharmacist is also an option.
- The pill should be taken at about the same time every day.
- Many pills are packaged to be taken for three weeks, with the fourth week consisting of placebo pills (or “sugar” pills). Most people will have bleeding during that fourth week.
- There are increasing options for how pills are packaged, such as pill packs that only have 4 days of placebo pills in a month and pills that are packaged with 12 weeks of active pills, followed by one week of sugar pills.
- Missing any pills increases the risk of pregnancy. This is particularly important at the end of the week of sugar pills, as ovulation (release of an egg) is more likely if there are too many days in a row without the use of active pills. People should receive specific “missed pill” instructions, including the use of emergency contraception (EC) when indicated.

Effectiveness (Risk of pregnancy)

- The effectiveness of using pills depends on using it correctly and consistently — by taking the pill each day at about the same time every day.
- With typical use, *8 women out of 100* become pregnant in the first year of use.
- Missing a pill, or not taking it at the same time every day, increases the chance of pregnancy.

Possible side effects

- Menstrual changes
 - Spotting between periods — especially in the first few months
 - Regular and lighter periods with fewer cramps
- Other possible side effects
 - Some mild nausea and/or breast tenderness (which usually improves over time)
 - Some people have less acne when taking pills
 - Research has shown that people who take the pill do not typically gain any more weight than they would gain without taking pills

Other considerations for taking pills

- Pills provide protection against ovarian cancer, uterine cancer and iron deficiency anemia.
- Current research indicates that pill use is not associated with breast cancer.
- People with heavy, painful periods can experience improvement in these symptoms with use of the pill.
- Some people should not use the pill because of specific health conditions, such as cardiovascular events (blood clots, heart attacks, strokes) or migraines.
- Cigarette smoking increases the risk of serious cardiovascular events (blood clots, heart attacks, strokes), especially for people over 35. People who use birth control pills are strongly advised not to smoke.
- People should not use an estrogen-containing methods for 3-6 weeks after delivering a baby, depending on their other medical conditions and whether they are breastfeeding.
- The client's healthcare provider can talk about potential risks and managing possible side effects of the pills.

Issues to explore with clients

- Ease and acceptability of remembering to take a pill every day.
- Whether the client has medical conditions that would make taking estrogen-containing contraception more dangerous, such as migraines, long-standing diabetes, and high blood pressure.

Key reminders for clients

For the pills to be highly effective, you must take your pills every day, at about the same time. What can help you remember to take your pill every day — at about the same time? What will you do if you miss a pill?

If at any time you are dissatisfied with your method, or you want to change methods, please come back to see us.

If you miss pills, you can use emergency contraception (EC) to prevent pregnancy. To find out where you can get EC, ask a pharmacist, call a family planning clinic, or visit the website

<http://ec.princeton.edu/emergency-contraception.html>

Remind all of your clients about the use of condoms to help reduce the risk of sexually transmitted disease (STDs), including HIV infection.

Reference for effectiveness rates: Sundaram A. Contraceptive failure in the United States. *Perspect Sex Reprod Health* 2017;49:7-16.

Progestin-Only Pills (POP)

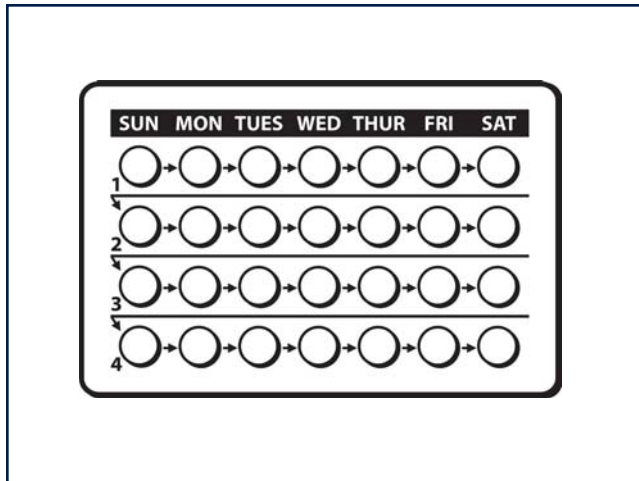

How progestin-only pills work

- Progestin-only pills (POP), sometimes called “minipills,” contain only one hormone — progestin.
- Progestin stops the body from releasing an egg, so no egg can be fertilized.
- Progestin also causes the cervical fluid (liquid at the opening of the uterus) to thicken, which can stop sperm from getting into the uterus..

How to use progestin-only pills

- In most states, POPs require a prescription from a qualified healthcare provider. In some states, consultation with a pharmacist is also an option.
- Progestin-only pills must be taken on time, at about the same time every day. The pills only work for 24 hours, so there is no effect once this time period has passed (which is different than with combined oral contraceptive pills).
- If a user misses any pills, or takes a pill more than 3 hours late, or has diarrhea or vomiting, they could be at risk for pregnancy. People using POPs should receive information about Emergency Contraception (EC).
- Unlike with combined oral contraceptive pills, there is no placebo or “sugar” pill week with POPs. The hormonal pills are taken throughout the month, with no break between packs.
- Pills can be started immediately after abortion or childbirth, even if breastfeeding.

Effectiveness (Risk of pregnancy)

- The effectiveness of using pills depends on using it correctly and consistently — by taking the pill each day at about the same time every day.
- With typical use, *9 women out of 100* will become pregnant in the first year of use.
- Missing a pill, or not taking it at the same time every day increases the chance of pregnancy.

Possible side effects

- Menstrual changes
 - Spotting between periods

Other considerations for taking progestin-only pills

- The progestin-only pill has fewer health risks than combination birth control pills and can be given to people who cannot take estrogen.
- Because it has no estrogen, its use is not limited among people with conditions such as migraine.
- Current research indicates that pill use is not associated with breast cancer, and it can reduce the risk of anemia.
- POPs are sometimes prescribed in the immediate post-partum period, as people are not advised to use estrogen-containing methods for the first 3-6 weeks after delivering a baby due to the risk of blood clots and potential effects on breastfeeding.
- The client's healthcare provider can talk about potential risks and managing possible side effects of the pills.

Issues to explore with clients

- Ability to take a pill at the exact same time every day, and understanding of the risk of pregnancy involved with even a slight delay in taking the POP
- Feelings about irregular bleeding between periods, which is more common with use of these methods

Key reminders for clients

For the progestin only pills to be highly effective, it is especially important for you to take them every day, at about the same time. What might be the most helpful way for you to remember to take your pill every day — and at about the same time? What will you do if you miss a pill ... or a couple of pills?

If at any time you are dissatisfied with your method, or you want to change methods, please come back to see us.

If you miss pills, you can use emergency contraception (EC) to prevent pregnancy. To find out where you can get EC, ask your pharmacist, call your local family planning clinic, or visit the website <http://ec.princeton.edu/emergency-contraception.html>

Remind all of your clients about the use of condoms to help reduce the risk of sexually transmitted disease (STDs), including HIV infection.

Reference for effectiveness rates: Trussell J. Contraceptive failure in the United States. *Contraception* 2011; 83: 397-404

Patch

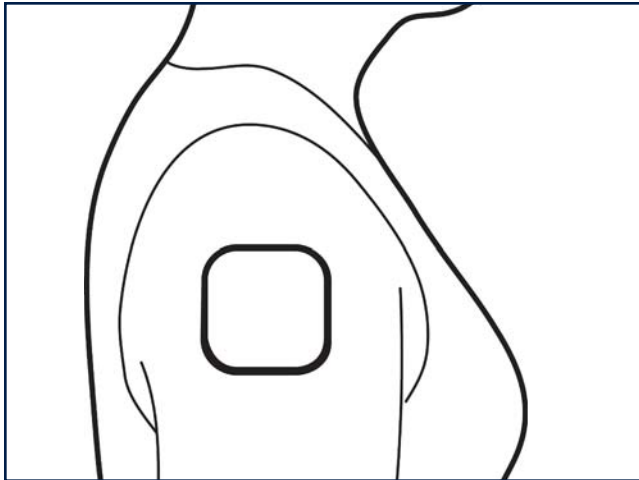

How the patch works

- The birth control patch is a thin, stick-on, square, 1-3/4 inch patch.
- The patch contains hormones (estrogen and progestin) that are similar to hormones that are produced naturally in the body. When using the patch, these hormones enter the bloodstream through the skin.
- The hormones in the patch work by stopping the body from releasing an egg, so no egg can be fertilized.
- The hormones in the patch also work by thickening the cervical fluid (liquid at the opening of the uterus) which can stop sperm from getting into the uterus.

How to use the patch

- In most states, the patch requires a prescription from a qualified healthcare provider. In some states, consultation with a pharmacist is also an option.
- The patch is a once-a-week (7 days) method of birth control on a four-week cycle. Written instructions come with the patch.
- A new patch must be used each week for three weeks; replaced on the same day of the week. The fourth week is patch-free.
- During the fourth week, no patch is used, and bleeding is expected.
- It is important to place a new patch promptly at the end of the patch-free week, as ovulation (releasing an egg) may occur if the period of time without a patch is extended.
- The patch is placed on healthy skin on the abdomen, buttock, lower back, upper outer arm or upper torso where it will not be rubbed by tight clothing.
- The patch should not be placed on the breast.

Effectiveness (Risk of pregnancy)

- The effectiveness of using the patch depends on using it correctly and consistently — by keeping the patch in place and replacing the patch each week on the same day of the week.
- With typical use, *9 women out of 100* become pregnant in the first year of use.
- Forgetting to replace the patch once every seven days, or forgetting to start a new cycle of patches after the fourth week, increases the chance of getting pregnant.

Possible side effects

- Menstrual changes
 - Spotting between periods — especially in the first few months
 - Regular and lighter periods with fewer cramps
- Other possible side effects
 - Some mild nausea and/or breast tenderness, which usually improves over time
 - Some people have less acne when using the patch.
 - Some people report skin irritation under and around the patch. To decrease the risk of skin irritation, the patch can be placed on a different part of the body each week.

Other considerations for using the patch

- The patch provides protection against ovarian cancer, uterine cancer and iron deficiency anemia.
- The patch stays on during a shower, bathing, swimming or other exercise. Warm, humid conditions do not decrease its sticking power.
- People with heavy, painful periods can experience improvements in these symptoms when using the patch.
- Some people should not use the patch because of specific health conditions, such as cardiovascular events (blood clots, heart attacks, strokes) or migraines.
- The Federal Drug Administration (FDA) placed a warning on the patch in 2005 because of findings of increased levels of estrogen compared to the pill and concern for a related increased risk of blood clots with the patch. Studies investigating this question have given variable results. If present, the absolute risk is likely to be small (15-50 per 100,000 women per year).
- Cigarette smoking increases the risk of serious cardiovascular events (blood clots, heart attacks, strokes), especially for those over 35. People who use the patch are strongly advised not to smoke.

- People should not use an estrogen-containing method for 3-6 weeks after delivering a baby, depending on their other medical conditions and whether they are breastfeeding.
- The client's healthcare provider can talk about the potential risks and managing possible side effects of the patch.

Issues to explore with clients

- Comfort and acceptability of wearing something on their skin
- Ease of remembering to change the patch every week
- Whether the client has medical conditions that would make taking estrogen-containing contraception more dangerous, such as migraines, long-standing diabetes, and high blood pressure

Key reminders for clients

For the patch to be highly effective, you must change the patch as directed. How can you remember to change your patch on time?

If at any time you are dissatisfied with your method, or you want to change methods, please come back to see us.

If you forget to place the patch on time, you can use emergency contraception (EC) to prevent pregnancy. To find out where you can get EC, ask a pharmacist, call a family planning clinic, or visit the website <http://ec.princeton.edu/emergency-contraception.html>

Remind all of your clients about the use of condoms to help reduce the risk of sexually transmitted disease (STDs), including HIV infection.

Reference for effectiveness rates: Trussell J. Contraceptive failure in the United States. *Contraception* 2011; 83: 397-404.

Vaginal Ring

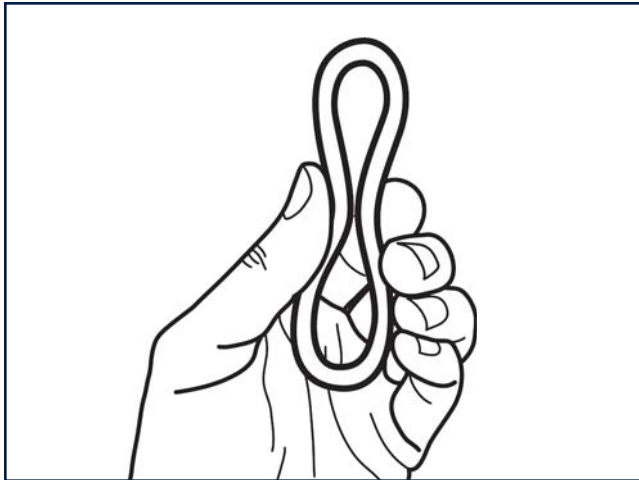

How the vaginal ring works

- The vaginal ring is a small (one size fits all), flexible transparent ring (two inches across) that is placed in the vagina.
- The ring releases a steady flow of low dose hormones (estrogen and progestin), which are similar to hormones that are produced naturally by the body.
- The hormones work by stopping the body from releasing an egg, so no egg can be fertilized.
- The hormones in the ring also work by thickening the cervical fluid (liquid at the opening of the uterus) which can stop sperm from getting into the uterus.

How to use the vaginal ring

- The vaginal ring requires a prescription from a qualified healthcare provider. In some states, consultation with a pharmacist is also an option.

- The vaginal ring is a once-a-month method of birth control. Written instructions come with the ring.
- The ring is placed in the vagina and left there for 21 days (3 weeks) where it releases a steady flow of hormones.
- During week four the ring is removed and bleeding will usually start two to three days later.
- A new vaginal ring must be inserted each month to continue to prevent pregnancy. It is important to insert the new ring immediately at the end of the ring-free week. If there is a delay, ovulation (releasing an egg) may occur.
- There are enough hormones in one ring to last for up to 35 days, which can provide some flexibility around when a person has bleeding.
- People can choose how long to wait before inserting a new ring, as long as it is not more than 7 days. To avoid bleeding, a person can insert a new ring immediately after removing the ring from the prior month (similar to continuous cycling with combined oral contraceptive pills).
- The exact placement of the ring is not important because it does not work as a barrier method of birth control.
- If the ring comes out, it can be rinsed off and reinserted. If it comes out for more than three hours, people should call a healthcare provider for specific instructions.

Effectiveness (Risk of pregnancy)

- The effectiveness of using the vaginal ring depends on using it correctly and consistently — by keeping the ring in place (see instructions) and replacing it each month.
- With typical use, *9 women out of 100* will become pregnant in the first year of use.
- Forgetting to replace the ring on time increases the chance of pregnancy.

Possible side effects

- Menstrual changes
 - Spotting between periods — especially in the first few months
 - Regular and lighter periods with fewer cramps
- Other possible side effects
 - Vaginal discharge can increase, but the ring is not associated with vaginal infections or bacterial vaginosis
 - Some people will have less acne when using the ring
 - Some mild nausea and/or breast tenderness (which usually improves over time)

Other considerations for the vaginal ring

- The vaginal ring provides protection against ovarian cancer, uterine cancer and iron deficiency anemia.
- There is no danger that the vaginal ring will be pushed up too far in the vagina or “lost.”
- Some people say they are aware that the ring is in their vagina, but it should not be felt by the user or their partner once it is in place.
- Some people should not use the ring because of specific health conditions, such as cardiovascular events (blood clots, heart attacks, strokes) or migraines.
- Cigarette smoking increases the risk of serious cardiovascular events (blood clots, heart attacks, strokes), especially for those over 35. People who use the vaginal ring are strongly advised not to smoke.
- People should not use an estrogen-containing method for 3-6 weeks after delivering a baby, depending on their other medical conditions and whether they are breastfeeding.
- The ring can be used immediately after an abortion.
- The client’s healthcare provider can talk about potential risks and managing possible side effects with the vaginal ring.

Issues to explore with clients

- Comfort with touching genitals to put the ring in place and to take it out
- Feelings about a method that needs to be changed every month
- Whether the client has medical conditions that would make taking estrogen-containing contraception more dangerous, such as migraines, long-standing diabetes, and high blood pressure

Key reminders for clients

For the ring to be highly effective, you must change the ring as directed. How will you remember to change your ring on time?

If at any time you are dissatisfied with your method, or you want to change methods, please come back to see us.

If you forget to place the ring on time, you can use emergency contraception (EC) to prevent pregnancy. To find out where you can get EC, ask a pharmacist, call a family planning clinic, or visit the website <http://ec.princeton.edu/emergency-contraception.html>

Remind all of your clients about the use of condoms to help reduce the risk of sexually transmitted disease (STDs), including HIV infection.

Reference for effectiveness rates: Trussell J. Contraceptive failure in the United States. *Contraception* 2011; 83: 397-404.

Diaphragm and Cervical Cap



How the diaphragm and cervical cap work

- The diaphragm is a dome-shaped rubber (latex) cup with a stiff rim.
- It's used with a special gel or cream that contains a spermicide (a substance that kills sperm).
- The diaphragm and spermicide are inserted together into the vagina and over the cervix to keep sperm from entering the uterus.

How to use the diaphragm and cervical cap

- The diaphragm or cervical cap comes in different types and several sizes. Each user must be fitted for a diaphragm by a trained health provider.
- The diaphragm or cervical cap should be checked for holes or weak spots, especially around the rim. A diaphragm with a hole should not be used.
- The diaphragm or cervical cap should be refitted after a pregnancy (especially after a vaginal birth) and after weight gain or weight loss of ten pounds or more.
- Oil-based lubricants, such as hand lotion or petroleum jelly, or vaginal medications (e.g., for yeast infections) should never be used because they can damage the diaphragm or cervical cap.

Before Inserting

- The user empties their bladder (pees) and washes their hands.
- A tablespoon of spermicidal gel is squeezed into the diaphragm cup or cervical cap.
- The diaphragm or cervical cap is inserted into the vagina as instructed when it was fitted. It must cover the cervix. Insert a finger into the vagina to check that the diaphragm or cervical cap is in place.
- Both the diaphragm and cervical cap are effective as soon as they are inserted.

Diaphragm	Cervical Cap
Can be inserted up to 2 hours before sexual intercourse	Can be inserted up to 42 hours before sexual intercourse

After Sex

- The diaphragm or cervical cap should be left in place for at least six hours after sex. Avoid douching with either device in place.

Diaphragm	Cervical Cap
Should not be in the vagina more than a total of 24 hours	Should not be in the vagina for more than a total of 48 hours
If the user had sex more than once, additional spermicidal gel should be added into the vagina before intercourse without moving the diaphragm.	The user does not need to apply additional spermicide if they have sex more than once during the time the cap is in place.

- The diaphragm or cervical cap is removed by slipping a finger into the vagina and under the rim to gently slide it out.

Effectiveness (Risk of pregnancy)

- The effectiveness of using a diaphragm or cervical cap depends on how well the instructions for how to use it are followed.

Diaphragm	Cervical Cap
With typical use, 12 women in 100 will become pregnant in the first year of use.	With typical use, 23 women in 100 will become pregnant in the first year of use.

- If a person uses the diaphragm or cervical cap according to instructions, each time they have sex, chances of pregnancy decrease.

Possible side effects

- Some people are allergic to latex rubber or to the spermicidal gel or cream. If this happens, women can try another brand.

Diaphragm	Cervical Cap
Some users find that the diaphragm may cause bladder irritation or an increased risk of bladder infections. If there is any pain or discomfort with urination, they should see a health care provider.	The cervical cap has not been associated with bladder infections.

Other considerations for the cervical cap or diaphragm

- It's important that the provider give the client instructions about insertion and provides time to practice inserting and removing the device.
- These methods have very few side effects or major health risks.
- Getting a cervical cap or diaphragm may require an exam and a fitting from a qualified healthcare provider. Both methods require a prescription.

Issues to explore with clients

- Feelings about using a non-hormonal device that can be used only when needed, but does not have to interrupt sex
- Comfort with touching genitals to put a diaphragm or cervical cap in place and take it out
- Will the cervical cap or diaphragm and spermicide be available when needed? Are they comfortable buying spermicide in a drug store, health clinic or online?

Key reminders for clients

For the diaphragm to be highly effective, you must follow the instructions and use it every time you have sex. How can you remember to have your diaphragm with you when you might need it?

If at any time you are dissatisfied with your method, or you want to change methods, please come back to see us.

If you do have unprotected sex, you can use emergency contraception (EC) to prevent pregnancy. To find out where you can get EC, ask your pharmacist, call your local family planning clinic, or visit the website: <http://ec.princeton.edu/emergency-contraception.html>

Remind all of your clients about the use of condoms to help reduce the risk of sexually transmitted disease (STDs), including HIV infection.

Reference for effectiveness rates: Trussell J. Contraceptive failure in the United States. *Contraception* 2011; 83: 397-404.

Male Condom

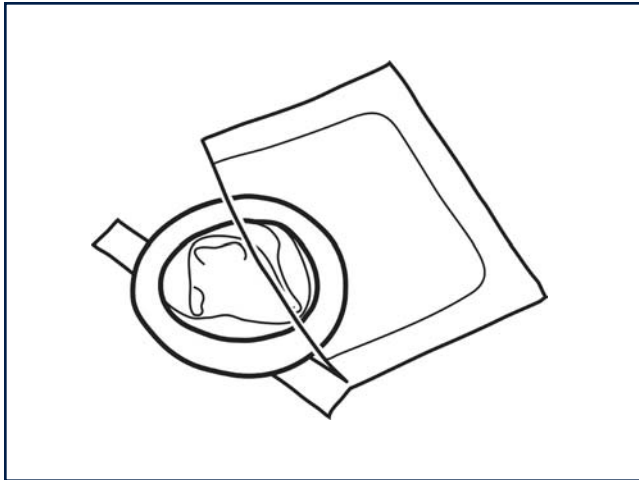

Note: The male condom may also be referred to as the external condom.

How the male condom works

- The male condom, or external condom, is a thin sheath that fits over the erect penis.
- Most condoms are made from latex (rubber) or polyurethane (synthetic condoms).
- For the prevention of pregnancy, it works as a physical barrier to stop sperm from getting into the vagina.
- For the prevention of transmission of sexually transmitted infections and HIV infection, condoms work as a barrier between partners so body fluids (i.e., semen, blood, vaginal secretions, and saliva) are not shared during sexual activity.

How to use the male condom

Before Sex

- Users should check the expiration date and avoid using a condom with an expired date.
- A new condom should be used for every act of vaginal, anal and oral sex throughout the entire sex act (from start to finish).
- Lubrication is important to decrease the chance of breakage. A lubricant can be added to the condom or to the vagina. For latex condoms, only water-based lubricants like K-Y Jelly®, Astroglide®, or spermicidal creams or foam should be used. Oil-based lubricants (e.g. baby oil, hand lotion, petroleum jelly, or cooking oil) can weaken the condom and cause it to break or tear.
- The condom should be placed on the tip of the erect penis with the rolled side out, leaving a half-inch space for semen to collect, and unrolled all the way to the base of the erect penis.

After Sex

- Immediately after ejaculation and before the penis gets soft, the rim of the condom should be held and the penis carefully withdrawn.
- Throw it away (don't flush it!).

Effectiveness (Risk of pregnancy)

- The effectiveness of using a male condom for birth control depends on using it correctly — following the package instructions — with each act of sexual intercourse.
- With typical use *13 women out of 100* will become pregnant in the first year of use.

Possible side effects

- Some people are allergic to latex (rubber). If you or your partner has a latex allergy, you can switch to one of the several synthetic condoms.

Other considerations for male condoms

- Condoms (latex and synthetic) are safe and effective for preventing pregnancy and reducing the transmission risk of HIV and sexually transmitted infections such as chlamydia, gonorrhea, trichomoniasis, and hepatitis B.
- Condoms may also provide some protection against STIs that are transmitted primarily through skin-to-skin contact (e.g., herpes, HPV, and syphilis).
- Using spermicide with condoms increases their effectiveness in preventing pregnancy. If spermicide is used frequently (more than twice a day) it can irritate the vagina and increase risk of transmitting HIV.

Issues to explore with clients

- Both partners' feelings about use of a barrier method
- The ease of using a method that requires planning ahead and having a condom on hand
- Comfort with buying condoms in a drug store or health clinic (noting that they can be ordered online)
- Feelings about using a lower effectiveness method, with its increased likelihood of pregnancy

Key reminders for clients

For condoms to be effective for preventing a pregnancy, you need to use them every time you have sex. How easy is it for you to use them all the time? How will using condoms work for you — and your partner — in the future?

If at any time you are dissatisfied with your method, or you want to change methods, please come back to see us.

If your condom breaks or slips, you can use emergency contraception (EC) to prevent pregnancy. To find out where you can get EC, ask a pharmacist, call a local family planning clinic, or visit the website <http://ec.princeton.edu/emergency-contraception.html>

Reference for effectiveness rates: Sundaram A. Contraceptive failure in the United States. *Perspect Sex Reprod Health* 2017;49:7-16.

Female Condom

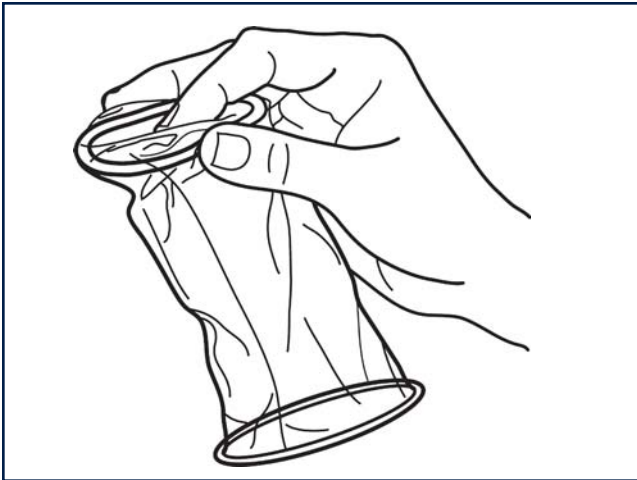

Note: The female condom may also be referred to as the internal condom.

How the female condom works

- The female condom (FC), or internal condom, is a soft, loose-fitting sheath (pouch) that works as a physical barrier and lines the vagina during sexual intercourse to keep sperm from entering the vagina.
- The FC has a soft ring at each end of the pouch. The closed end of the pouch (along with a ring) is used to put the condom into the vagina to hold it in place. The open end stays outside of the vagina. The open end ring is used as a guide to insert the penis into the vagina.
- The FC also works as a barrier between partners that provides protection from sexually transmitted infections including HIV infection.

How to use the female condom

Before Sex

- The FC package has instructions and drawings that show how to put it in.
- Always check the expiration date.
- Insert it up to 8 hours before intercourse.
- Keep the outer ring outside the vagina.
- During sex the condom may move around. If the outer ring starts to be pushed into the vagina, or if the penis starts to go up along the outside of the condom, the condom should be taken out and another condom should be used.

After Sex

- Squeeze and twist the outer ring to keep the semen from spilling, and gently pull the condom out.
- Throw it away (don't flush it!).
- Female and male condoms should not be used together; they can stick together, causing one or both of them to slip out of place.

Effectiveness (Risk of pregnancy)

- The effectiveness of using female condoms for birth control depends on using it correctly — following the package instructions — with each act of sexual intercourse.
- With typical use *21 women out of 100* will become pregnant in the first year of use.
- If the female condom isn't used every time, or if it slips or breaks, or is put in or taken out the wrong way, the chance of pregnancy increases.
- Female condom use becomes more effective with practice. A user can practice putting it in before using it with a partner.

Possible side effects

- There are few side effects; if a user experiences a possible allergic reaction or irritation, they can try another type or brand of condom.

Other considerations for female condoms

- Female condoms are non-hormonal with no known health risks, are user-controlled, and provide protection against pregnancy and some sexually transmitted infections such as chlamydia, gonorrhea, trichomoniasis, hepatitis B, and HIV infection.
- Female condoms may also provide some protection against STIs that are transmitted primarily through skin-to-skin contact (i.e., herpes, HPV, and syphilis).
- The non-latex material is stronger and less likely to cause allergic reactions than latex condoms.
- Female condoms are more expensive than male condoms.

Issues to explore with clients

- Comfort with touching genitals to put the female condom in place and take it out
- Whether it's important to have a barrier method that the client can control
- The ease of using a method that requires planning ahead
- The acceptability of barrier methods
- Comfort with buying female condoms in a drug store or health clinic (noting that they can be ordered online)
- Feelings about using a lower effectiveness method, with its increased likelihood of pregnancy

Key reminders for clients

For these condoms to be effective for preventing a pregnancy, you need to use them every time you have sex. How easy is it for you to use them all the time? How will using female condoms work for you in the future?

If at any time you are dissatisfied with your method, or want to change methods, please come back to see us.

If your condom breaks or slips, you can use emergency contraception (EC) to prevent pregnancy. To find out where you can get EC, ask a pharmacist, call a local family planning clinic, or visit the website <http://ec.princeton.edu/emergency-contraception.html>

Remind all of your clients about the use of condoms to help reduce the risk of sexually transmitted disease (STDs), including HIV infection.

Reference for effectiveness rates: Trussell J. Contraceptive failure in the United States. *Contraception* 2011; 83: 397-404

Sponge

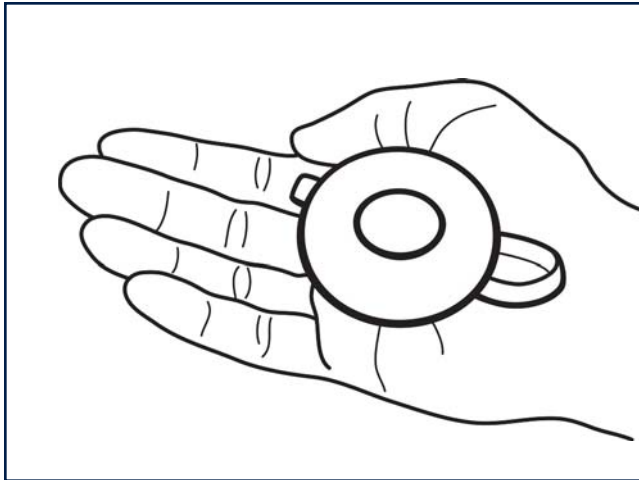

How the sponge works

- The Today® sponge is a small, one-size, disposable (single use), over-the-counter method of birth control for women.
- It contains spermicide (a substance that kills sperm) to prevent pregnancy.
- The sponge is inserted into the vagina and placed in front of the cervix as a barrier that keeps sperm from entering the uterus.
- The smooth side of the sponge has a woven loop of polyester fabric that provides easy removal of the sponge.

How to use the sponge

Before Sex

- To use the sponge correctly, follow the instructions in the package.
- Remove the sponge from its package and moisten the sponge with tap water just before inserting it into the vagina. Gently squeeze to produce “suds” that will activate the spermicide and help with insertion.

- Slide the sponge into the vagina along the back wall of the vagina until it rests against the cervix. The dimple side should be up against the cervix, with the loop away from the cervix.
- Insert a finger into the vagina to check that it is in place.
- The sponge is effective immediately for up to 24 hours, with one or multiple acts of intercourse and no need to add more spermicide.

After Sex

- After intercourse, the sponge must be left in place for at least six hours before it is removed. Do not leave in place for more than 24-30 hours.
- To remove the sponge, grasp the loop on the sponge with one finger and gently pull.
- Check to be sure the sponge is in one piece; if it is torn, remove all pieces.
- Throw the sponge away (don't flush it!).

Effectiveness (Risk of pregnancy)

- The effectiveness of the sponge depends on using it correctly and consistently according to the package instructions - every time with sexual intercourse.
- With typical use, *12 women out of 100 (who have not experienced childbirth)* will become pregnant in the first year of use.
- With typical use, *24 women out of 100 (who have experienced childbirth)* will become pregnant in the first year of use.
- If the sponge is not used every time or it slips out of place, the chance of pregnancy increases.

Potential side effects

- Allergic reaction to the spermicide in the sponge
- Consult a health care provider if you and/or your partner are allergic to sulfa drugs.

Other considerations for the sponge

- The sponge should not be used during a menstrual period, immediately after childbirth, miscarriage, or abortion.
- The sponge should not be worn for more than 24-30 hours after insertion (including the six hour waiting time after intercourse) because of the possible risk of Toxic Shock Syndrome (TSS) — a rare but serious disease.
- The sponge is not recommended for people who have had TSS symptoms in the past. Danger signs for TSS:
 - Sudden high fever
 - Vomiting, diarrhea
 - Dizziness, faintness, weakness
 - Sore throat, aching muscles and joints
 - Rash (like a sunburn)

Issues to explore with clients

- Comfort with touching genitals to put sponge in place
- Ability to plan ahead and make sure sponge are available when needed
- Comfort with buying sponge in a drug store or health clinic (noting that they can be ordered online)
- Feelings about using a lower effectiveness method, with its increased likelihood of pregnancy

Key reminders for clients

For the sponge to be effective, you need to check the expiration date, follow the instructions, and use it every time you have sex. How easy will it be for you to always have sponges available when you need them?

If at any time you are dissatisfied with your method, or you want to change methods, please come back to see us.

If you have unprotected sex, you can use emergency contraception (EC) to prevent pregnancy. To find out where you can get EC, ask your pharmacist, call your local family planning clinic, or visit the website <http://ec.princeton.edu/emergency-contraception.html>

Remind all of your clients about the use of condoms to help reduce the risk of sexually transmitted disease (STDs), including HIV infection.

Reference for effectiveness rates: Trussell J. Contraceptive failure in the United States. *Contraception* 2011; 83: 397-404.

Spermicides

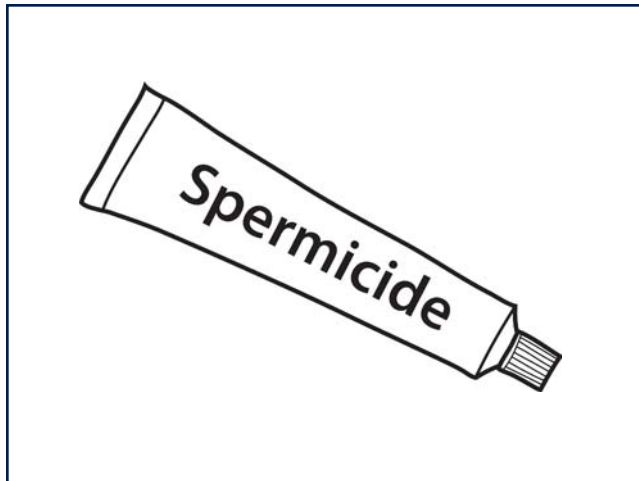

- Most spermicides must be in the vagina for no more than one hour before sex.
- People should avoid douching after using spermicides because it makes this method less effective.

Effectiveness (Risk of pregnancy)

- The effectiveness of spermicides depends on using it correctly and consistently according to the package instructions — every time with sexual intercourse.
- With typical use, *28 women out of 100* will become pregnant in the first year of use.
- To increase the effectiveness, spermicides can be used with a male condom (external condom).

How vaginal spermicides work

- Spermicides contain chemicals that kill sperm. In the U.S. nonoxynol-9 is the active chemical used in spermicides.
- Vaginal spermicides come in several forms (gel, foam, cream, film, suppository, or tablet).
- Some spermicides are used along with a diaphragm (i.e., gels, creams) or condoms but they can also be used alone.

How to use vaginal spermicides

- To use vaginal spermicides correctly, it is very important to follow the instructions in the package.
- Often the package instructions will provide drawings and give specific advice about how soon the method is effective (e.g., immediately after insertion or to wait 10-15 minutes).

Potential side effects

- Allergic reactions; trying a different brand may help.

Other considerations for spermicides

- Frequent use of spermicides (more than 2 times per day) can cause internal vaginal irritation and increase transmission risk of HIV infection.

Issues to explore with clients

- Comfort with touching genitals to put spermicides in place
- Ability to plan ahead and make sure spermicides are available when needed
- Comfort with buying spermicides in a drug store or health clinic (noting that they can be ordered online)
- Feelings about using a lower effectiveness method, with its increased likelihood of pregnancy

Key reminders for clients

For spermicides to be effective, you need to check the expiration date, follow the instructions, and use them every time you have sex. How easy will it be for you to always have spermicides available when you need them? Using condoms with the spermicide will increase effectiveness.

If at any time you are dissatisfied with your method, or you want to change methods, please come back to see us.

If you have unprotected sex, you can use emergency contraception (EC) to prevent pregnancy. To find out where you can get EC, ask your pharmacist, call your local family planning clinic, or visit the website <http://ec.princeton.edu/emergency-contraception.html>

Remind all of your clients about the use of condoms to help reduce the risk of sexually transmitted disease (STDs), including HIV infection.

Reference for effectiveness rates: Trussell J. Contraceptive failure in the United States. *Contraception* 2011; 83: 397-404.

Withdrawal

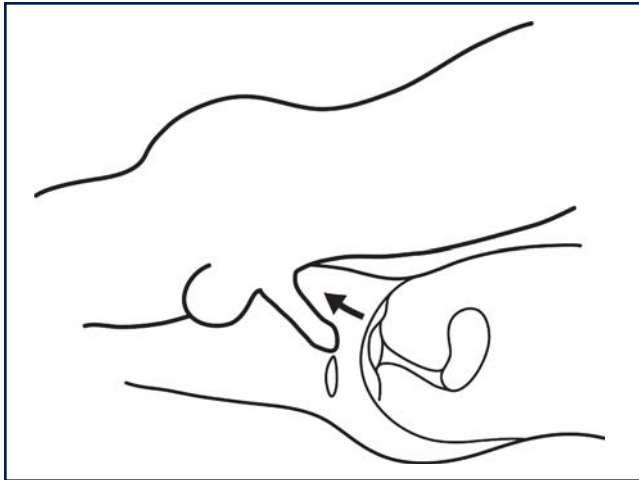

How withdrawal works

- Withdrawal prevents fertilization by not allowing semen (and sperm) to enter the vagina; sperm does not reach the egg. It is also called *Coitus Interruptus*.

How to use withdrawal

- While having intercourse, before ejaculating, a person pulls their penis out of their partner's vagina and away from their partner's genitals.
- The person withdrawing must depend on their judgment of their physical sensations to decide when they are about to ejaculate in order to withdraw in time.

Effectiveness (Risk of pregnancy)

- The effectiveness of using withdrawal depends on using it correctly and consistently — specifically on the ability to withdraw the penis before ejaculation.
- With typical use, *20 women out of 100* will become pregnant in the first year of use.
- People who are less experienced with using this method or who have a difficult time knowing when they will ejaculate will have a greater risk of failure.

Possible side effects

- This method has no health risks or side effects.

Other considerations when using withdrawal

- There is nothing to buy.
- Withdrawal is an acceptable method for some couples with religious preferences related to the use of birth control.
- It is a backup method if no other methods are available.

Issues to explore with clients

- Whether a person will be able to consistently withdraw their penis before they ejaculate
- Whether interruption of the sexual excitement phase may decrease pleasure
- Feelings about using a lower effectiveness method, with its increased likelihood of pregnancy
- For the partner who may become pregnant, feelings about using a method controlled by their partner

Key reminders for clients

For withdrawal to be effective you must use it the right way and each time you have sex. How will that work for you and your partner?

If at any time you are dissatisfied with your method, or you want to change methods, please come back to see us.

If you do have unprotected sex and don't want to be pregnant, you can use emergency contraception (EC) to prevent pregnancy. To find out where you can get EC, ask a pharmacist, call a family planning clinic, or visit the website <http://ec.princeton.edu/emergency-contraception.html>

Remind all of your clients about the use of condoms to help reduce the risk of sexually transmitted disease (STDs), including HIV infection.

Fertility Awareness-Based (FAB) Methods

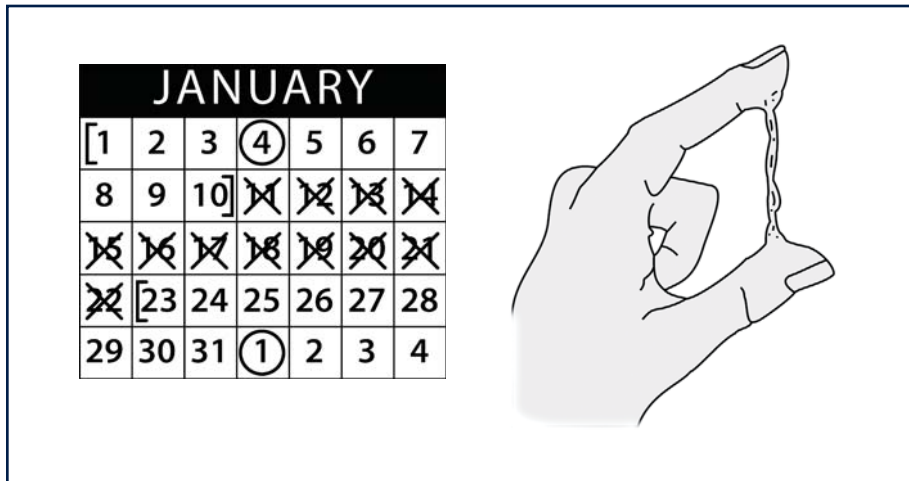

Use of FAB methods

There are several FAB methods that rely on information about the timing of a person's menstrual cycle, changes in their cervical fluid, and/or their basal body temperature.

- A menstrual cycle is counted from the first day of bleeding in one month to the first day of bleeding the next month (usually 23–35 days). The most fertile time is when ovulation occurs, usually in the middle of the menstrual cycle.
- Cervical fluid (healthy vaginal discharge) changes throughout each menstrual cycle. After each menstrual period ends, there may be no cervical fluid to notice in the vaginal area. These are “dry” days. As ovulation approaches (and a person becomes more fertile), the fluid becomes more wet and stretchy (like egg white).
- Morning body temperature rises within about 12 hours of ovulation and stays at this slightly higher range until around the time of the next period.

These FAB methods use a calculation to identify the fertile days:

- Standard Days Method (SDM) using CycleBeads® — based on statistical information about women who have regular menstrual cycles and can be used by those who have cycles between 26 and 32 days long. Counting from the first day of a period, days 8 through 19 of the menstrual cycle are considered the fertile days.
- Calendar Rhythm Method (CRM) — count and record days in each menstrual cycle for six months and predict future fertile days (when pregnancy can occur) using a standard calculation.

These FAB methods rely on observing bodily changes:

- TwoDay Method — track cervical fluid every day, twice a day. People are considered fertile when they have secretions on either that day or the day prior.

What are FAB methods?

- The Fertility Awareness-Based (FAB) Methods work by identifying the “fertile time” each month — the days when intercourse would most likely result in pregnancy — and either not having sex during these days or using a birth control method like condoms.

Preventing or achieving pregnancy

- FAB methods help a person (or couple) become more familiar with the signs of ovulation and the pattern of the menstrual cycle to help plan sexual activity to avoid or plan a pregnancy.
- Checking the specific signs of fertility every day of the person's menstrual cycle can show when they are fertile.
- During the fertile time, not having intercourse or using a barrier method (i.e., condoms) can prevent pregnancy.
- FAB methods can be used to prevent a pregnancy or plan a pregnancy.

- Ovulation Method — observe and chart cervical fluid and identify fertile days using an approach such as the trademarked Billings method.
- Symptothermal Method — observe and record cervical fluid as well as changes in basal body temperature (BBT).

Note: Providers will need additional detailed information and educational resources to teach clients about FAB methods.

Effectiveness (Risk of pregnancy)

- The effectiveness of using fertility awareness based methods for birth control depends on using the method correctly and consistently. Because there are various approaches to fertility awareness based methods the effectiveness rates vary.
- With typical use *24 women out of 100* who use FAB methods become pregnant in the first year of use.
- These methods can be effective if the instructions are followed carefully for each menstrual cycle. Fertility products are available to help keep track of the changing fertility signs.

Other considerations when using FAB methods

- Using FAB methods can increase awareness and understanding of one's body and there are no health risks or side effects.
- These methods can be used as birth control as well as provide very helpful information for planning a pregnancy.
- Couples may develop greater communication, cooperation and responsibility using these methods. The method is more effective with cooperation between sexual partners.
- These methods may be more acceptable for those with religious preferences related to the use of birth control.
- Learning these methods takes time and practice.
- Using these methods consistently and correctly takes commitment, calculation, and planning.
- It is recommended that individuals interested in these methods receive individualized instruction on the chosen FAB method..

Issues to explore with clients

- The ability to and comfort with tracking each menstrual cycle and/or cervical fluid
- Plans to prevent pregnancy on fertile days
- Clients can get information about fertility-based methods on the internet (type words such as “fertility awareness” or “natural family planning” into any search engine) and through smart phone “apps.” Fertility monitoring products can be found in drug stores or online. Some information and products are more reliable than others.
- Information about CycleBeads® and the SDM is available at www.cyclebeads.com.

Key reminders for clients

If at any time you want to talk about other birth control methods, please come back to see us.

Emergency contraception (EC) to prevent an unintended pregnancy is available. To find out where you can get EC, call us, ask a pharmacist, call a local family planning clinic, or visit the website <http://ec.princeton.edu/emergency-contraception.html>

Remind all of your clients about the use of condoms to help reduce the risk of sexually transmitted disease (STDs), including HIV infection.

Reference for effectiveness rates: Trussell J. Contraceptive failure in the United States. *Contraception* 2011; 83: 397-404.

Abstinence



- It is very effective when both partners are completely committed and practice abstinence (no genital contact) 100% of the time.
- Abstinence is most effective when both partners talk and agree about their reasons to remain abstinent.

Other considerations for abstinence

- Abstinence has no health risks, is free, available to anyone, at any time.

Issues to explore with clients

- How easy it will be to avoid situations that may make it more difficult to use abstinence consistently.

Key reminders for clients

For abstinence to be effective you must consistently not have sex 100% of the time. How well is it working for you? How will it work for you in the future?

If at any time you want to learn more about and/or use a birth control method, please come back to see us.

If you do have unprotected sex, you can use emergency contraception (EC) to prevent pregnancy. To find out where you can get EC, ask your pharmacist, call your local family planning clinic, or visit the website <http://ec.princeton.edu/emergency-contraception.html>

Remind all of your clients about the use of condoms to help reduce the risk of sexually transmitted disease (STDs), including HIV infection.

How abstinence works

- Sexual abstinence is defined by individuals in many different ways.
- Sexual abstinence for pregnancy prevention is defined as not having any penis-to-vagina contact during sexual activity.

How to use abstinence

- People who use abstinence should be encouraged to talk with their partner(s) about this decision and decide in advance what sexual activities are a “yes” and what activities are a “no.”
- Those who use abstinence should be aware that using drugs and/or alcohol may influence sexual decisions and increase the risk of pregnancy and sexually transmitted infections.
- Abstinence is a choice people can use at any time and at any age.

Effectiveness (Risk of pregnancy)

- When used consistently, total abstinence is very effective protection against pregnancy and reducing the risk of sexually transmitted infections including HIV infection.

Breastfeeding Using the Lactational Amenorrhea Method



How breastfeeding works for birth control

- Lactational Amenorrhea Method (LAM) is a short-term birth control method based on the natural effect of breastfeeding on fertility.
- Breastfeeding after having a baby may work to prevent pregnancy for up to six months post-partum.
- Three necessary conditions for the LAM method are:
 - Menstrual periods have not returned.
 - Only food is breast milk. No other foods or liquids are given either day or night.
 - The baby is less than 6 months old.

Breastfeeding for birth control is not recommended if a person answers "yes" to any question below:

1. Have your periods returned?
2. Are you giving your infant other food, supplements or formula; either day or night?
3. Is your baby more than six months old?

To continue being protected, a person should have a new method of birth control ready before answering "yes" to any of these questions.

How to use breastfeeding for birth control

- Follow the instructions above for using breastfeeding for birth control.
- Before the person no longer meets all three criteria above, they should be ready with another method of birth control to avoid pregnancy.
- The parent should breastfeed as often as the baby wants, both day and night. They should not give other foods or liquids if using breastfeeding as birth control.
- The parent should continue to breastfeed even if they or the baby are sick.
- A healthcare provider or lactation educator can answer questions and offer support for breastfeeding and for using LAM for birth control.

Effectiveness (Risk of pregnancy)

- If all three criteria are met, breastfeeding can be more than 98% effective.
- Effectiveness will greatly decrease as soon as breastfeeding is reduced, formula, any liquid or regular food are introduced, menses returns, or when the baby reaches six months.

Other considerations for breastfeeding as birth control

- Ovulation may occur before the person's periods return after childbirth. As a result, if they don't follow the guidelines of this method, they could become pregnant again before their period returns.

Issues to explore with clients

- How long they plan to exclusively breastfeed
- What method they plan to use when breastfeeding no longer protects against pregnancy

Key reminders for clients

If at any time you want to use a birth control method, please come back to see us. What might you want to use after this method is no longer effective?

Remind all of your clients about the use of condoms to help reduce the risk of sexually transmitted disease (STDs), including HIV infection.

Emergency Contraceptive Pills (ECP)

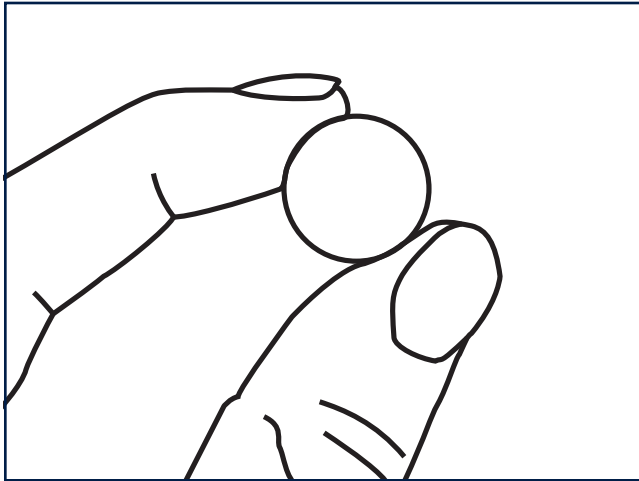

How emergency contraceptive pills work

- Emergency contraceptive pills (ECP) are used AFTER sexual intercourse.
- ECP works primarily by stopping a person's body from releasing an egg (ovulation), so there is no egg present to be fertilized.
- Emergency contraception may prevent pregnancy, but it will not stop an already-established pregnancy or harm a developing fetus.

How to use emergency contraceptive pills

- ECPs should be taken as soon as possible (within 5 days) after unprotected intercourse or as directed by a health provider or pharmacist.
- There are two types of ECP's. The first type contains progestin and is available in many forms including over-the-counter. The second type contains ulipristal acetate (called ella® in the U.S.).

- If breastfeeding, people who use ulipristal should pump and discard their breastmilk for 24 hours after taking it.
- People should wait 5 days after taking ulipristal to start taking birth control pills.
- Some combination birth control pills can be taken as emergency contraception as directed by a healthcare provider or pharmacist.
- In the days or weeks after taking ECP, a person should use condoms and/ or another birth control method until they have a period.
- If a person's period does not start within three weeks, they should take a pregnancy test at home or see a healthcare provider for a pregnancy test.

Effectiveness (Risk of pregnancy)

- Taking emergency contraceptive pills may reduce a person's chance of pregnancy after unprotected intercourse if taken within 5 days of unprotected sexual intercourse.
- How effectiveness is calculated for ECP is different from other birth control methods. ECP effectiveness rates are based on the pregnancy risk after a single act of sexual intercourse.
- Studies show a range of effectiveness that depends on which ECP product is taken, how soon after sex it is taken (up to 72 hours or 120 hours) and on which day of the menstrual cycle unprotected intercourse occurred.
- ECP's can be less effective in people who are overweight or obese. A healthcare provider can help choose the ECP which is most effective for a client depending upon their weight.
- Using ECP routinely is less effective than other available contraceptives.
- After taking ECP, unprotected intercourse should be avoided until another birth control method is used.
- A healthcare provider can discuss other birth control options after ECP use.

Possible side effects

- Side effects with ECP are rarely reported. A few people report nausea. Medicine for nausea is available.
- ECP may change the amount, duration, and timing of the next menstrual period.

Other considerations for emergency contraceptive pills

- Emergency contraceptive pills can be taken at any time a person is concerned about unprotected intercourse that may cause pregnancy. Examples of when they can be used include after:
 - The condom (male or female) slips, breaks or leaks
 - A missed birth control pill(s)
 - A diaphragm or cervical cap is inserted incorrectly or removed too early
 - Any other birth control method is used incorrectly
 - Exposure to some medicines, drugs or other toxic agents (which can reduce the effectiveness of some methods)
 - Nonconsensual unprotected sex

Issues to explore with clients

- The copper IUD is also a highly effective method of emergency contraception (EC). See the Intrauterine Device (IUD) fact sheet.
- For more information visit <http://ec.princeton.edu/emergency-contraception.html>

Key reminders for clients

Other methods of birth control are more effective than using emergency contraceptive pills. Would you like to talk about other birth control methods today?

If at any time you want to talk about other methods, please come back to see us.

Remind all of your clients about the use of condoms to help reduce the risk of sexually transmitted disease (STDs), including HIV infection.

Reference for effectiveness rates: Trussell J. Contraceptive failure in the United States. *Contraception* 2011; 83: 397-404.

Seven Strategies for Effective Education

For clients to make informed decisions and follow treatment plans, information needs to be presented clearly and simply. It should be culturally and linguistically appropriate and reflect the client's beliefs, ethnic background and cultural practices. The amount of information presented should be limited to essential points, and tailored to the needs and knowledge gaps of that individual. Help your clients understand risks and benefits by using clear numbers and comparisons, and providing balanced, positive messages. Ask clients to show and tell you what they have learned. This is called using “teach-backs.” And finally, a client encounter should include a counseling and education approach that is interactive and engaging.

Provide information that is clear and easy to understand

- ▶ Whether you're with a client, in a group, or writing materials, keep it simple! Substitute a short word for a long one: “use” instead of “utilize.” If you do use complicated terms, also say it more simply: “use it every time you have sex and always the right way.” Instead of “use birth control consistently and correctly.”



Use culturally and linguistically appropriate messages

- ▶ Don't make assumptions about your clients' beliefs, religion, or customs, but do ask — respectfully. Ask a question such as, “Is there anything I should know about you — about your culture, beliefs, or religious or other practices that would help me take better care of you?” This makes it clear that you're asking so that you can better serve them, not just because you're nosy.

Tailor information to the individual client

- ▶ Focus on your client's needs and knowledge gaps. What are the 3 to 5 most important educational messages that this individual client should walk away with knowing? That's as much as most of us will remember, so focus on those important messages. Highlight or circle these key points on any handouts you provide.

Share balanced information

- ▶ Present advantages and benefits of contraception as well as potential side effects, risks, and warnings in an accurate and unbiased way. Ensure clients know about the range of birth control options available. Using a neutral approach, ask about and explore concerns the client may have and sensitively correct any misinformation. For example, if you are talking about pills you can say “for most women pills are safe with no side effects. Some women do have side effects but often they go away or we can help manage them by changing the prescription.”

Use clear numbers and comparisons

- ▶ Frame your information with numbers use a consistent format and frame the information positively: For example, when talking about contraceptive effectiveness use “99 out of 100 women who typically use this method will not get pregnant.” Use simple graphs and visuals to help clients understand the information correctly.

Engage the client in an interactive conversation

- ▶ Actively engage your client by asking questions and giving information that your client needs to know. Use a question and answer style to help clients learn and remember important information. Ask “What questions do you have?” rather than, “Do you have any questions?” Use interactive teaching methods such as writing or circling tailored messages on your educational materials.

Use teach-backs to confirm understanding

- ▶ Ask clients to tell you, in their own words, what they're going to do: “We've covered a lot today, so I want to be sure that I was clear. Can you tell me what you'll do if you miss taking a pill?” Ask your clients to show you, as well. “I just showed how to put a condom on the model; now you try!” During teach-backs provide encouragement and respectfully correct mistakes.

Source: Providing Quality Family Planning Services: Recommendations of CDC and the U.S. Office of Population Affairs, 2014; Appendix E



Quality Family Planning
www.fpntc.org

How Do I Choose?

Things to think about when choosing a birth control method



What is important to me in a birth control method for me and my partner?

How would I support my partner to take a pill every day?

Would I (could I) stop during sex to use a condom?

How could I support my partner to get a shot every 3 months?

How would I feel if my partner got pregnant?

What would it be like to talk to my partner about birth control?

Do I need protection from STDs?

Will I use a condom every time?

Would I consider sterilization?



Quality Family Planning
www.fpntc.org

How Do I Choose?

Things to think about when choosing a birth control method

What is really important to me in a birth control method?

What would it be like to talk to my partner about this?

Would I (could I) stop during sex to use a condom?

How would I manage to get my shot every 3 months?

How will I do at taking a pill every day?

How would I feel if my period changed? If I had spotting between periods, or no periods at all?

Are there people in my life whose opinions I need to think about?

Is it okay if other people know I'm on birth control?

How do I feel about putting something inside me?

How would I feel if I got pregnant?

Would I consider sterilization?

Do I need protection from STDs?



Quality Family Planning
www.fpntc.org

Conducting a Sexual Health Assessment

Starting the Conversation

Transitional statements can help you move comfortably from addressing the client's stated needs into assessing the need for other services.

Examples:

"Having a healthy pregnancy and baby starts with keeping your body healthy. I'd like to ask you some questions about your sexual health."

"The same things that put you at risk for being pregnant may put you at risk for getting an STD. I'd like to ask you some questions about your sexual health."

A **normalizing statement** helps put the client at ease and lets them know that a sexual health assessment is an important part of providing comprehensive services.

Examples:

"These questions may feel very personal, but know that we ask all clients these questions so that we can provide the best care possible."

"I ask these questions at least once a year of all my clients because they are very important for your overall health."

Helping the Client Feel Comfortable

Effective interviewing and counseling skills are essential to obtaining an accurate and complete sexual history.

Providers should strive to establish and maintain client rapport throughout the assessment.

▶ Show respect and compassion for the client

▶ Use open-ended questions

Example: *"Tell me about any new sex partners you've had since your last visit."*

▶ Use understandable, nonjudgmental language

Example: *"Are your sex partners men only, women only, or both men and women?"*

▶ Use normalizing language throughout the assessment

Example: *"Some of my clients have difficulty using a condom with every sex act. How is it for you?"*



Sources:

CDC. Sexually transmitted diseases treatment guidelines, 2015. MMWR 2015;64(No. 3). www.cdc.gov/std/tg2015/
CDC. A guide to taking a sexual history. Atlanta, GA: US Department of Health and Human Services, CDC. www.cdc.gov/std/treatment/sexualhistory.pdf
National LGBT Health Education Center, National Association of Community Health Centers. Taking routine histories of sexual health. 2013.
Providing Quality Family Planning Services: Recommendations of CDC and the U.S. Office of Population Affairs, 2014.
California Department of Public Health STD Control Branch, California STD/HIV Prevention Training Center. A clinician's guide to sexual history taking. 2011.

Conducting a Sexual Health Assessment

Five Ps

You may find the “Partners” section is a comfortable place to begin your assessment, or you may find it is more natural to begin with another section based on that client’s unique visit (for example, if the client came in for a pregnancy test, you might begin with Pregnancy Prevention).

Remember, these questions follow your transitional statement and/or introducing the reasons for asking these personal questions.

Partners: It might be necessary to define the term “partner” to the client or use other, relevant terminology. Remember: never make assumptions about the client’s sexual orientation.

Tell me about any current or recent partners you’ve had sex with?

If needed: *To help me understand, do you have sex with men, women, or both?*

In the past 2 months, how many partners have you had sex with? How about in the past 12 months?

Is it possible that any of your partners in the past 12 months had sex with someone else while still in a sexual relationship with you?

Is there anything else you’d like to tell me about your partner(s)?

Past STD History: Begin with “I’m going to ask you about past sexually transmitted diseases, because the likelihood of you getting an STD is higher if you or your partners have had one in the past.”

What STDs have you had in the past, if any?

Have any of your partners had an STD?

Pregnancy:

What are your current plans or desires regarding pregnancy?

If not wanting to be involved in a pregnancy: *What are you doing to prevent pregnancy?*

What’s been your experience with using your current method? OR Do you have a method in mind you might want to use?

Practices: Begin with “To understand your risks for STDs, I need to understand the kind of sex you have had recently.”

What kinds of sex do you have or have you had? (for example, oral sex, vaginal sex, anal sex, sharing sex toys)

Some clients may feel more comfortable with simple, direct questions:

Have you had vaginal sex, meaning penis in vagina? Have you had anal sex, meaning penis in rectum/anus? Have you had oral sex, meaning mouth on penis/vagina?

Is there anything else about your sexual practices that I need to know about to ensure I can provide you with good care?

Protection from STDs:

What do you do to protect yourself from STDs and HIV?

Tell me about your use of condoms when you have [vaginal, anal, oral] sex.

If a client uses condoms inconsistently: *In what situations (or with whom) do you use condoms?*

If a client never uses condoms: *There are lots of reasons why people don’t use condoms; what might be your reasons?*

Concluding the Assessment:

Is there anything else about your sexual practices and health that I need to know about to ensure I can provide you with good health care?

What other concerns or questions about your sexual health would you like to discuss?

Interactive Contraceptive Counseling and Education

Counseling is an interactive process that enables your client to make and follow through on decisions. Providing quality contraceptive counseling is an essential component of client-centered care.

Counseling is a dialogue; it's a conversation. Counseling includes exploring the client's experiences, feelings and beliefs to help facilitate the client's decision making.

The approach used in counseling is to help clients understand themselves better and to follow through on their decisions.

Education is an integral component of the counseling process that provides accurate information so that clients can make informed decisions.

Information needs to be presented clearly and simply. It should be culturally and linguistically appropriate and reflect the client's beliefs and practices. The amount of information presented should be limited to essential points, and tailored to the needs and knowledge gaps of that individual.

Education is never one-way; it should be interactive and engaging.

A quality client-centered counseling and education encounter is interactive, engaging, nonjudgmental and respectful of the client's goals and preferences.

COUNSELING	EDUCATION
<i>What do you know about the different methods of birth control?</i>	<i>Let me show you this chart of methods and we can talk about the ones that might work for you.</i>
<i>What's the most important thing for you in a birth control method?</i>	<i>If it's most important that you don't get pregnant right now, the most effective methods are the ones that have one procedure and then you can forget about them — like an IUD or an implant.</i>
<i>What methods have you used in the past... how did they work for you?</i>	<i>The most important way for a method to be effective is for you to be able to use it consistently and correctly — in other words — every time you have sex and always the right way.</i>
<i>It sounds like you've heard things about IUDs that make you worried...</i>	<i>We now have a lot of research that tells us that IUDs are really safe for most women.</i>
<i>How concerned are you about side effects with pills?</i>	<i>Often, if a woman has side effects with one pill a provider can make a change in her prescription...</i>
<i>What things might get in the way of you returning to the clinic to get your shot?</i>	<i>If you can't make it to the clinic in time for your shot, be sure to have a backup plan — like having condoms around.</i>
<i>How might your partner feel about using a condom — every time you have sex?</i>	<i>Now that we've talked about condoms, tell me how you'd use condoms — step-by-step.</i>
<i>Before you leave, I just want to ask you — What do you know about Emergency Contraception?</i>	<i>EC is available over-the-counter now. Let's circle (or write down) the name of a drug store near you where you could get EC anytime.</i>



Quality Family Planning
www.fpntc.org



Appendix D: Effective Teaching Methods for Training Staff¹

This handout is a snapshot of many teaching methods available to you for staff training. Some ways to develop your comfort and confidence in using a new method include:

- Observe experienced educators/trainers using the method;
- Assess your own comfort level, expertise, values and skills required;
- Think through for yourself when, where, how and why you would use the method;
- Practice using the method with colleagues;
- Co-lead a session using the method with an experienced colleague.

Method	How it works	Examples
Brainstorm	Quick listing of responses to a question. Rules: no criticism, be creative, have fun, piggyback on each other's ideas. Make sure you gather input from all participants.	To stimulate creative thinking, hold up a box of baking soda and ask learners to quickly come up with as many uses for the product as they can. Acknowledge the creativity of the group; move directly into another brainstorm on the topic or another activity requiring creative thought. Ask all participants to write down 3 responses to the question, go around the room and elicit one from each before going into full group brainstorming.
Case studies	Using stories to help learners relate to the topic and/or solve a hypothetical problem.	Have learners in small groups create a story about the topic and tell their story to the other groups. Create ethical dilemmas (with characters similar to the learners or learners' clients) for the learners to discuss and resolve.
Charts & graphs	Visual display of factual information. Statistics can be important but hard to grasp. Visual representations of statistics and other facts can help learners absorb new information.	Use a chart during presentation or discussion to illustrate statistical information. Fill a jar with variously colored marbles, with one particular color representing teen pregnancy or frequency of an STD. Have participants draw marbles from the jar; the ones who draw the special marbles are "pregnant."



Method	How it works	Examples
Continuum	A physical way to show a range of beliefs. Alternative: Have learners complete an anonymous survey; collect surveys, mix them up and hand back out so participants represent another's view. It is essential to precede this activity with a discussion on values and respect for others' opinions.	Draw a line (real or symbolic) across the room. At one end there is an extreme belief about an issue (ex., parental consent for abortion, abstinence from sex outside of marriage, etc.) and at the other end is the opposite extreme. The space between represents the range of beliefs in between. Learners place themselves at the point along the line which best represents their feelings or beliefs.
Discussion	Learners talk about the issue, in small groups or in the full group, with or without the instructor. It's helpful to establish group ground rules first.	Show a part of a video, stopping it at a critical moment. Start discussion by asking open-ended questions: What do you think about interactions of the characters? Who can you relate to? During a brief presentation, ask open-ended questions: What would you do if...? How might you use this information?
Games	The only rule here is to have fun while learning. The game may be competitive or not; structured or not; based on a "real" game or not.	In small groups, assign learners the task of teaching back a topic to the rest of the group as a game show. They can choose whatever game they want. Create your own game based on any game or board show: Jeopardy, Bingo, Trivial Pursuit, etc.
Graffiti sheets	Invite anonymous responses from learners on easel paper posted around room. This can be used to assess knowledge, determine beliefs or values or to stimulate discussion.	Write the Principles for Providing Quality Counseling, ask participants to write examples under each. Write sentence stems such as: The "best" birth control for teens ...; The most effective method is...; The "perfect" method is ...; A method I would never use is...; etc. Ask learners to complete the sentences.
Learning stations	Work or subject stations are set up around the room that learners can visit	Invite learners to visit as many stations as they can and ask for oral reports. Assign learners to find something similar (or different) in each station.
Lecture or presentation	Information is presented to the group, often accompanied by PowerPoint slides or other visual displays. Factual information is important, and this is sometimes the best way to cover the information. Keep it brief and follow with interactive methods.	Liven up the lecture with appropriate humor, anecdotes or breaks for short discussions in dyads or triads. Replace statements with questions: From "some of the most common STDs are..." to "what are some STDs you've heard of?" Encourage personal reflection or application of the information.



Method	How it works	Examples
Realplays & roleplays	Practice of new skills through trial and feedback.	Ask learners to describe real scenarios they could find themselves in. Set up dyads or triads, or ask for volunteers to play out the scene using new skills or attitudes. You may provide sample scenarios of common situations to practice.
Reflective writing	An opportunity for individual reflection and writing on an issue.	Ask participants to write about a personal experience with behavior change prior to a discussion on behavior change theory. Create a journal: insert relevant quotes or drawings on some pages and leave other pages blank. Give students time to write during class and/or assign out-of-class writing.
Rehearsal	Exercises that provide a chance to practice a new skill or verbalize new information.	Write "one-liners" (could be difficult questions from clients) on 3x5 cards and distribute to learners. In pairs, they can practice responding to one-liners. After learning new information, students practice teaching it to small groups of peers.
Simulation	Not quite real life but comes as close to it as you can in the classroom!	Set up an experience which models real life: a clinic, a dating scene, a drugstore. Have learners provide the action: birth control counseling session, a frank discussion of making sexual decisions, buying condoms.
PowerPoint Slides	Visual aids accompanying a lecture/discussion. Don't overuse; keep in mind that the purpose is to provide a visual illustration, not simply giving the same information you have included in a handout or verbally.	Choose cartoons to illustrate exaggerated examples of poor communication skills or marketing ads that illustrate "sex sells." Develop colorful graphs or pie charts to "show" rather than simple tell statistics. Make slide photos of people's faces to humanize HIV or insert nature slides between factual slides to provide visual relief.
Sorting games	A way to practice using knowledge by applying it.	Write names of different birth control methods on cards. Students can sort cards by effectiveness rates or by "type" (non-prescription vs. prescription), etc. Write sexual topics for discussion (e.g., common myths about birth control, specific questions about how to use a method such as condoms, natural family planning, etc.) on cards. Have learners sort cards by difficulty. Then rehearse the difficult ones.
Stem sentences	Use sentence fragments to trigger discussion or ideas. Before a discussion or reading aloud, set ground rules, especially no criticism.	Write sentence stems on easel paper or on 3x5 cards, such as: The best birth control is..., The best birth control for a teen is..., One thing I learned today.... Participants read from cards, or move around room answering those they want. (See graffiti sheets.)



Method	How it works	Examples
Task groups	Small group within a group that accomplishes a set task. Usually follows acquisition of new knowledge or skills.	Assign a group of participants to develop a teaching approach for clients about the menstrual cycle and how it relates to birth control. Have a group of participants develop a definition for sexual health, another for emotional, for social, physical, spiritual, environmental, etc.
Value voting	Exercise to develop awareness of one's own and of other's values and beliefs. It helps to have a brief discussion of values first, emphasizing respect for differences. You can allow a discussion about the items, or not, but if you do, establish ground rules first.	Develop a list of value statements about the topic, with "Agree/Disagree" next to each. Have learners read the list and agree or not with each statement. Collect and shuffle papers and redistribute. Either by show of hands or getting up and standing in different parts of the room, indicate whether the paper they're holding agrees or not. Example: IUD is a great method for teens (Agree/Disagree)
Videos	Can be used to demonstrate communication skills, trigger discussion, offer information in a highly visual manner.	Show part of video. Stop at critical moment for discussion: what would you do if you were this character? Before showing a video on communication skills, assign some participants to count the number of open-ended questions, others to count the reflective listening statements, etc. Have a small group rewrite the conclusion of the video and act out for the others.
Worksheets	Guidelines for thinking or working through a complex issue or problem. Can be used by an individual or small group.	Develop a worksheet that allows learners to apply their new information by comparing, categorizing, planning or reacting. Then in small groups, share their answers and develop action plans. Use a worksheet as a "pre-organizer," building on individual experiences (about making a difficult decision or taking risk, etc.) before talking about a topic.
Whip	A simple exercise to provide everyone an opportunity to speak. Always give permission to "pass."	Stop the session mid-way and "whip" around the room, asking everyone to state how they're reacting to the session. Whip before talking about a new topic, asking for one idea about it from everyone.

¹This list is adapted from a Northwest Institute for Community Health Educators (NICHE) 1996 handout developed by Gail Stringer & Beth Reis. Many of the listed teaching methods are adapted from *Teaching About Sexuality and HIV: Effective Principles and Methods*, Hedgpeth and Helmich, NYU Press, 1996.



Quality Family Planning
www.fpntc.org

This toolkit was developed by Cardea, www.cardeaservices.org

Funding provided by the Department of Health and Human Services, Office of Population Affairs,
Cooperative Agreement # FPTPA006024